



Mechanische Messtechnik
Mechanical measuring instruments



Durchflussmesstechnik
Flow measuring instruments



Elektronische Mess- & Kalibriertechnik
Electronic measuring- & calibration instruments



SIKA Dr.Siebert & Kühn GmbH & Co. KG
Struthweg 7-9
D-34260 Kaufungen • Germany

 +49 (0)5605 803-0

 +49 (0)5605 803-54

 info@sika.net

 www.sika.net



Operating manual (Translation)

BetriebsanleitungSeite 1 - 24

Operating manual page 25 - 48



Digital pressure gauges

Reference type E2 / D2



Table of contents	page
0 About this operating manual.....	27
1 Device description	28
1.1 Intended use.....	29
1.2 Exclusion of liability	29
2 Safety instructions.....	30
3 Display, functions and measuring process.....	31
4 Connection and battery replacement	33
4.1 Connection.....	33
4.2 Battery replacement	34
5 Commissioning, switching on and off	35
5.1 Commissioning.....	35
5.2 Switching on and off.....	35
6 Measuring mode and operation of the Functions.....	36
6.1 Measuring mode	36
6.1.1 Menu for device settings.....	37
6.2 Operation of the functions.....	38
6.3 Functions in the menu for device settings	40
7 Maintenance and cleaning, storage and transport.....	42
8 Disassembly and disposal.....	43
9 Technical data	44
10 EC Declaration of Conformity.....	46

Copyright notice:

The reproduction, distribution and utilization of this operating manual as well as the communication of its contents to others without express authorization is prohibited. Offenders will be held liable for the payment of damages. All rights reserved in the event of the grant of a patent, utility model or design.

0 About this operating manual

- The operating manual is aimed at specialists and semi-skilled personnel.
- Before each step, read through the relevant advice carefully and keep to the specified order.
- Thoroughly read and understand the information in the section "Safety instructions".

If you have any problems or questions, please contact your supplier or contact us directly at:



Dr. Siebert & Kühn GmbH & Co. KG
 Struthweg 7-9 • D - 34260 Kaufungen
 ☎ 05605-803 0 • 📠 05605-803 54
 info@sika.net • www.sika.net

Hazard signs and other symbols used:



WARNING! / CAUTION! Risk of injury!

This sign indicates dangers that cause personal injuries that can lead to health defects or cause considerable damage to property.



CAUTION! Risk of injury in the case of excessive pressure!

This sign indicates dangers which could arise from excessive pressure in a piece of equipment.



CAUTION! Material damage!

This sign indicates actions which could lead to possible damage to material or environmental damage.



ADHERE TO OPERATING MANUAL!



NOTICE!

This symbol indicates important notices, tips or information.



NO DOMESTIC WASTE!

The device must not be disposed of together with domestic waste.



Pay attention to and comply with information that is marked with this symbol.



Follow the specified instructions and steps. Adhere to the given order.



Check the specified points or notices.



Reference to another section, document or source.



Item.

1 Device description

The references E2 / D2 are digital manometers with actual value and MIN/MAX displays. They are used to measure stationary and mobile pressures.

They have a rugged housing made of cast zinc with a rubber protection cap ①. The electronics unit, the 4 1/2 -digit LCD digital display ②, the control panel ③ and the replaceable batteries are housed inside the device.

The references have accuracies of ±0.5 % Type E2 and ±0.1 % Type D2, relative to the corresponding full-scale reading (FS).

Used as a pressure reference, they provide an easy way of checking, adjusting and calibrating other items of pressure measuring equipment.

Components:

The most important components of the E2 / D2 are

- ① Cast zinc housing with rubber protection cap.
- ② LCD display with backlight.
- ③ Control panel with buttons.
- ④ G1/4" pressure connection shanks.
- ⑤ Type plate.
- ⑥ Rear cover with fastening screws.
- ⑦ Gasket in the pressure port.



Versions:

The references E2 / D2 differ in terms of their accuracy and are available for the following pressure ranges.

Pressure range	Reference E2		Reference D2	
	Accuracy (FS)	Resolution	Accuracy (FS)	Resolution
-1...3 bar	±0.5 %	1 mbar	±0.1 %	1 mbar
-1...40 bar	±0.5 %	10 mbar	±0.1 %	10 mbar
-1...60 bar	±0.5 %	10 mbar	±0.1 %	10 mbar
0...400 bar	±0.5 %	100 mbar	±0.1 %	100 mbar
0...700 bar	±0.5 %	100 mbar	±0.1 %	100 mbar
0...1000 bar	±0.5 %	100 mbar	±0.1 %	100 mbar

Type plate:

The type plate is located on the back of the E2 / D2. It contains the most important data (→Example).



Type plate example

Scope of delivery:

Before using the device, check the delivered items:

- 1x E2 / D2 according to the order data.
- 1x Operating manual.
- Packaging or transport protection (if applicable).

**1.1 Intended use**

The digital manometer E2 / D2 is intended solely for inspecting, adjusting and calibrating pressure measuring equipment.

Do not use the reference E2 / D2 outside the specifications and do not disregard the operating instructions.

**WARNING! No safety component!**

the reference E2 / D2 is not a safety component in accordance with Directive 2006-42-EC (Machine Directive)..

↳ Never use the reference E2 / D2 as a safety component.

The operational safety of the device supplied is only guaranteed by intended use. The specified limits (→ § 9 "Technical data") may under no circumstances be exceeded.

This applies especially to the compliance with the permissible full-scale reading and the permissible temperature range.

**DANGER! Risk of injury or material damage in the case of excessive pressure!!**

Exceeding the maximum overload values can lead to material failure of the digital manometer. At the same time, that can cause serious harm to health.

↳ Make sure that the overload values are never exceeded.

Before ordering and installation, check that the reference is suitable for your applications.

1.2 Exclusion of liability

We accept no liability for any damage or malfunctions resulting from incorrect installation, in-appropriate use of the device or failure to follow the instructions in this operating manual.

2 Safety instructions



Before you install the E2 / D2, read through this operating manual carefully. If the instructions contained within it are not followed, in particular the safety guidelines, this could result in danger for people, environment, device and the system it is connected to.

The E2 / D2 correspond to the state-of-the-art technology. This concerns the accuracy, the operating mode and the safe operation of the device.

In order to guarantee that the device operates safely, the operator must act competently and be conscious of safety issues.

SIKA provides support for the use of its products either personally or via relevant literature. The customer verifies that our product is fit for purpose based on our technical information. The customer performs customer- and application-specific tests to ensure that the product is suitable for the intended use. With this verification all hazards and risks are transferred to our customers; our warranty is not valid.

Qualified personnel:

- ⚠ The personnel who are charged for the installation, operation and maintenance of the E2 / D2 must hold a relevant qualification. This can be based on training or relevant tuition. The personnel must be aware of this operating manual and have access to it at all times.
- ⚠ The electrical connection should only be carried out by a fully qualified electrician.

General safety instructions:

- ⚠ In all work, the existing national regulations for accident prevention and safety in the workplace must be complied with. Any internal regulations of the operator must also be complied with, even if these are not mentioned in this manual.
- ⚠ Degree of protection according to EN 60529:
Ensure that the ambient conditions at the site of use does not exceed the requirements for the stated protection rating (→ § 9 "Technical data").
- ⚠ Only use the E2 / D2 if it is in perfect condition. Damaged or faulty devices must be checked without delay and, if necessary, replaced.
- ⚠ When fitting, connecting and removing the E2 / D2 use only suitable appropriate tools.
- ⚠ Do not remove or obliterate type plates or other markings on the device, as otherwise the warranty is rendered null and void.

Special safety instructions:

Warnings that are specifically relevant to individual operating procedures or activities can be found at the beginning of the relevant sections of this operating manual.

3 Display, functions and measuring process

For inspecting, adjusting or calibrating, the digital manometer E2 / D2 must be connected to a pressure generator and the pressure measuring equipment to be tested.

The section "Measurement process" uses examples to describe the calibration process using a P40.2 pneumatic hand pump as a pressure generator and a mechanical manometer as the unit under test.

Display and control panel:

- ① Measured value display.
- ② Control panel with buttons.
- ③ Bar graph display with drag indicator function.
- ④ Unit display.
- ⑤ Status line.



The digital pressure gauge E2 / D2 has a LCD display with additional elements and a graphic bar graph display.

The measured values are displayed as numbers in the 4 ½ -digit display ①. The selected measurement unit ④ (bar, PSI, kPa, MPa, kg/cm², mH₂O) is displayed next to the measurement value.

The bar graph display ③ represents the pressure range of 0 to 100% in graphic blocks. The drag indicator function shows pressure peaks with a single line.

In the status bar ⑤, the battery symbol  indicates the current battery level. Next to that, depending on the default, the MIN-, MAX- or FS value is shown.

The measuring mode (→ § 6.1) and the menu for device settings (→ § 6.1.1) are operated using the four buttons on the control panel ②.

Function of the reference:

Signals from the pressure measurement cells are recorded at a sampling rate of 10 ms (100 measurements/s), converted into pressure values and displayed. The high sampling rate means that dynamic pressure peaks can also be measured. These are written to the MIN/MAX memory, which is continuously updated.

The reference E2 / D2 supports daily pressure measurements with practical functions such as MIN/MAX display, display filter, zero function, pressure unit adaptation, illumination, battery level display and a programmable Auto-Off function.

Measurement process:

Connect the reference E2 / D2 ① and the test unit ③ to the hand pump ②.

For the measurement process, it is important that the same pressure is applied to the reference and to the test unit. That is ensured with the P40.2 pneumatic hand pump.

The E2 / D2 reference is screwed via the pressure connection shanks ⑦ directly to the hand pump. Connect the test unit with a flexible pressure hose ④.

Then use the hand pump to build up the pressure and set the required testing points.

The measurements and the additional information are shown in the LCD display ⑤ of the reference E2 / D2.

Control and set the functions with the control panel membrane buttons ⑥.

As soon as the pressure has stabilised on the pressure points, the current measurements are read.

The measurements of the test unit and the reference are logged and evaluated.

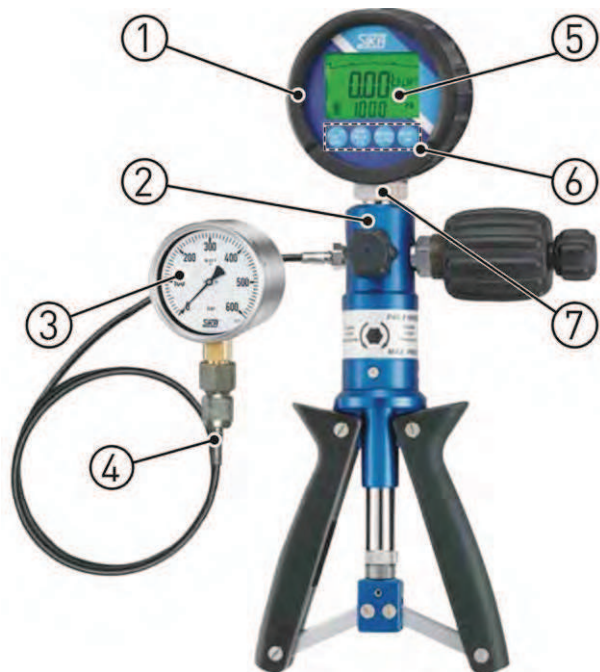

Example measurement setup with hand pump .

4 Connection and battery replacement

The digital manometer E2 / D2 has a G $\frac{1}{4}$ " (BSPP) male thread and is supplied with batteries fitted. The device is ready for operation after it is switched on (→ § 5.2).

WARNING! Material damage and risk of injury!

Comply with the nominal pressure specifications of the measurement port and the adapter!



The connection (WAF 27) is approved up to a nominal pressure of 1,000 bar.

↪ Observe the nominal pressure specifications of the integrated measurement ports and the specified safety factors.

↪ Comply with the instructions in these operating manual!

In particular, improper installation of the manometer and the related adapter can lead to the manometer tearing off.

Please observe the following instructions when using the E2 / D2:

- Only authorised personnel are permitted to operate and control the device.
- The deployment location should be sufficiently bright and easy to operate.
- Take appropriate precautions to protect the device from damage.
- Pay attention to adequate protection against weather. Observe the degree of protection according to EN 60529 (→ § 9 "Technical data").

4.1 Connection

↪ 1. Prepare the measurement setup for connection to the G $\frac{1}{4}$ " pressure connection shank.

⚠ Only use adapters with corresponding nominal pressure specifications!

↪ 2. Make sure that the gasket is correctly seated in the pressure connection shank.

↪ 3. Carefully turn the reference by hand into the measurement setup thread.

↪ 4. Tighten the pressure connection shank with an open-end wrench (WAF 27).

⚠ You must assemble with a torque of 25 Nm.

↪ 5. Align the reference for your application.



IMPORTANT! Check for free turning.

The housing of the E2 / D2 can be rotated on the pressure connection shank. During direct assembly, make sure that no attachments interfere with the free turning.

4.2 Battery replacement

The battery capacity is continuously monitored by the electronics of the E2 / D2 and is indicated by the number of bars (0...5 bars) in the battery symbol.



The batteries should be replaced when no bar is visible and the battery symbol flashes. The E2 / D2 is still completely functional.

The batteries must be replaced when the additional message "Lo bAtt" appears. The E2 / D2 is no longer operational.



CAUTION! Observe the battery type and polarity!



Damage can be caused if a different type of batteries is used or the batteries are incorrectly inserted during replacement.

- ↪ Use only fresh batteries of the same type (LR6 - AA) when replacing.
- ↪ Pay attention to correct polarity when inserting.

Comply with the following instructions when replacing the batteries:

- ↪ 1. Switch off the device.
- ↪ 2. Press the top section of the rubber protection cap backwards over the housing and remove it in the downward direction over the pressure connection shank.
- ↪ 3. Open the housing:
Remove the screws from the rear cover.
Set the rear cover and the screws aside.
- ↪ 4. Remove the old batteries.
- ⚠ No domestic waste!
The batteries must be disposed of.
- ↪ 5. Insert the new batteries.
!!! Pay attention to the POLARITY !!!
- ↪ 6. Check the seating of the gasket in the rear cover and watch out for signs of damage.
- ↪ 7. Carefully attach the rear cover to the housing with the screws.
- ↪ 8. Re-tighten the rear cover screws.
- ↪ 9. Pull the rubber protection cap back over the housing.
While doing so, make sure the recess of the rubber bulge on the front is underneath the button panel.



5 Commissioning, switching on and off

The digital manometer E2 / D2 is supplied with batteries fitted. The device is ready for operation after it is switched on (→ § 5.2).

5.1 Commissioning

Before switching on the E2 / D2 for first time and when making changes in the measurement setup, follow the instructions below.

Check if

- all test setup components are connected to each other.
- all connections were made properly and are pressure-proof.

5.2 Switching on and off

Switch the E2 / D2 on and off with the **ON/OFF** button.

Switching on:

The device first performs a self-test and is subsequently in the measured value display.

- ↪ Briefly press the **ON/OFF** button.
 - All segments of the digital display will appear briefly.
 - After that, the pressure range (FS) of the device and the most recently used pressure unit are displayed.
 - The current setting of the automatic shut-off follows (P_0):
 - "on" = activated; "off" = deactivated.
 - Finally, the serial number and the installed software version of the device are displayed.
 - The device is subsequently ready and displays the current measurement values.

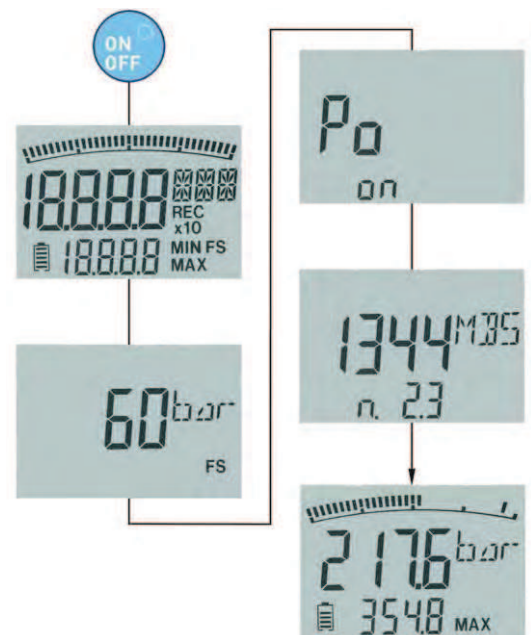

Switching off:

- ↪ Briefly press the **ON/OFF** button.
 - The device is switched off and the display is blank.

Automatic shut-off:

With activated " P_0 " function (on), the device switches off after 5 min (→ S. 40).

6 Measuring mode and operation of the Functions

After switching on and completion of the start-up procedure, the E2 / D2 enters measuring mode. The current reading is displayed.

6.1 Measuring mode

The following illustration shows the operation and functions in the measuring mode:

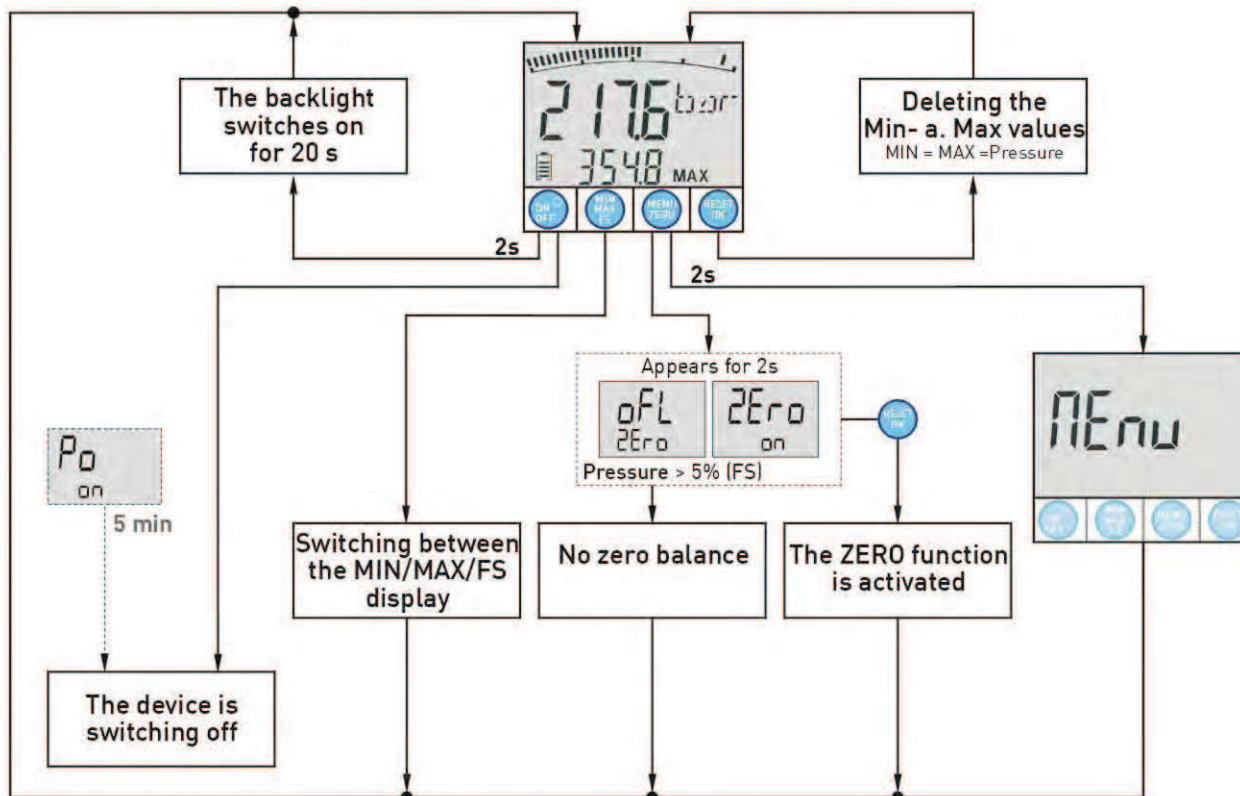

In measuring mode, you can activate the various functions (→ § 6.2) or call the Menu for device settings (→ § 6.1.1) for the E2 / D2 device.



ON/OFF button:

The **ON/OFF** button is used for switching the device on and off (→ § 5.2).

The gear button switches the backlight on for 20 s (→ § 6.2).



MIN/MAX/FS button:

Use the **MIN/MAX/FS** button to change the status bar between the minimum value (MIN), maximum value (MAX) and the pressure range (FS) (→ § 6.2).

The selection is displayed the next time the device is switched on.



MENU/ZERO button:

The **MENU** button is used to call the menu for the device settings.

Use the **ZERO** button to perform a zero balance.



RESET/OK button:

The **RESET** button deletes the current MIN and MAX values.

The **OK** button is used to confirm the selection in the menu.

6.1.1 Menu for device settings

The device functions "Automatic shut-off", "Units" and "Display filter" are configured in the menu for device settings.

The following illustration shows the procedure for creating the device settings:

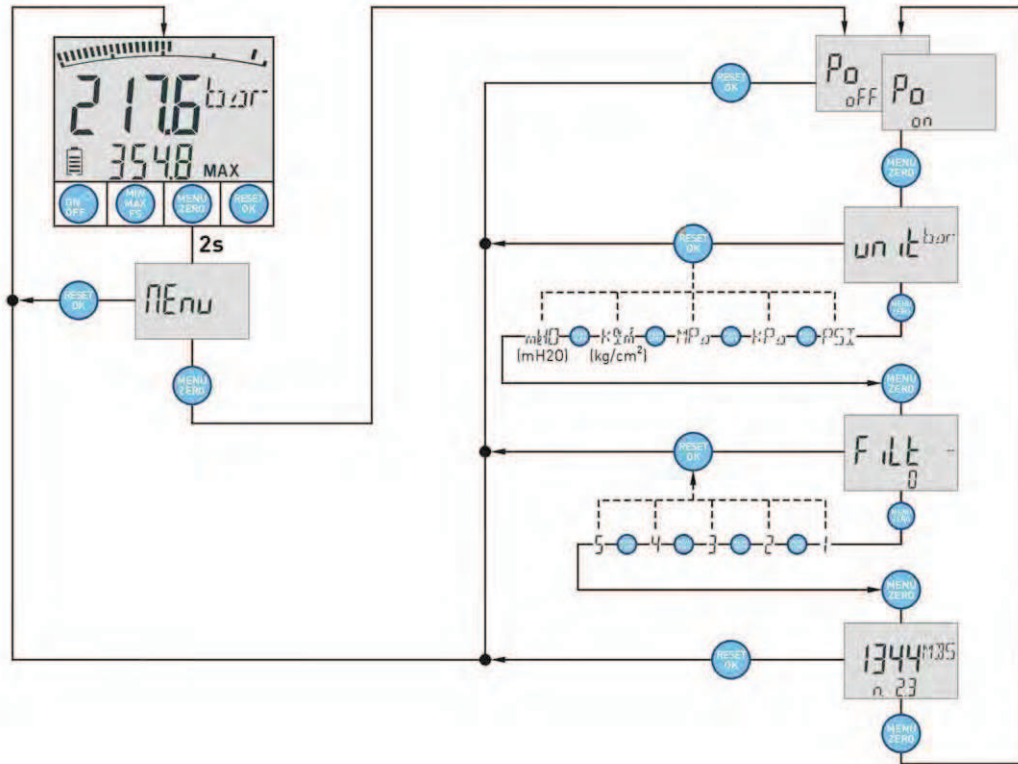

Call the device settings menu with the MENU button.

- ↩ Keep the MENU button pressed for 2 s.
 - "Menu" appears in the display.

The individual functions and the possible settings are controlled with the MENU button.

- ↩ Keep pressing the MENU button until the function with the desired setting appears..
- ↩ Press the OK button to save the setting of the function.
 - The selection is saved and the device switches back to measuring mode.



IMPORTANT! Automatic return!

If no button is pressed, the device switches back to measuring mode after 10 s.

6.2 Operation of the functions

The operation of the functions in the measuring mode and in the device settings menus are described in the sections below.

Backlight

- ↳ Press and hold the ON/OFF button for 2 s.
 - The display lighting switches on.
 - After 20 s, the lighting automatically switches off.

FS (Full Scale) display

The display of the end scale value (FS) is used to improve the legibility of the bar graph display. The end scale value of the pressure range is displayed numerically in the status bar.

- ↳ Press the MIN/MAX/FS button to switch between the MIN-, MAX- and FS display.
 - The status bar shows MIN, MAX and FS with the related values one after the other.

MIN/MAX display

The MIN/MAX function is used to measure pressure peaks. The MIN/MAX memory always has the lowest (MIN) and highest (MAX) measurement values respectively.

- ↳ Press the MIN/MAX/FS button to switch between the MIN-, MAX- and FS display.
 - The status bar shows MIN, MAX and FS with the related values one after the other.

The MIN/MAX memory is erased when switched off. If you want to perform various pressure tests consecutively, you must erase the MIN/MAX memory after each measurement.

Erasing the MIN/MAX values

- ↳ Press the RESET/OK button to erase the MIN/MAX values and the bar graph display drag indicator.
 - The MIN/MAX values are set to the current measurement value.

Out of measurement range / "oFL" display:

The "oFL" display appears when the current pressure lies outside of the pressure range ($\geq 110\%$ FS) of the E2 / D2. If the pressure falls below that, the current measurement value is displayed.

The MAX value continues to display "oFL" and must first be reset.

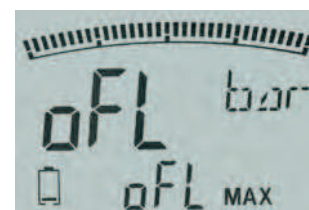

If the "oFL" display is shown in the pressure less state, there is a malfunction.

- ↳ Please contact SIKA.

Zero point correction (ZERO)

If there are undesired deviations in the pressure less state (atmospheric pressure), the zero point can be manually corrected.

CAUTION! Faulty measurements!



The zero point correction sets the current ACTUAL value to zero. If the ZERO function is activated when pressure is applied, the pressure measurement is no longer made against the ambient pressure, resulting in faulty measurements.

↪ Activate the ZERO function only in the pressure less state.

↪ Press the MENU/ZERO button.

- "ZEro on" appears in the display for 2 s. The ZERO function can be activated.
- ↪ Press the RESET/OK button to do the zero point correction.
- The display and the MIN/MAX values are zeroed.

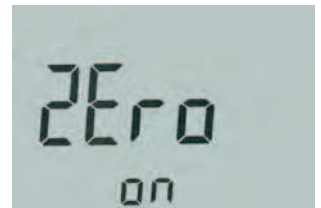

or

- "oFL ZEro" appears in the display for 2 s. The measured pressure (0 bar) is greater than 5% of the measurement range. The ZERO function cannot be performed.
- The device switches back to measurement mode.
- ↪ Create a pressure less state and press the MENU/ZERO button again.

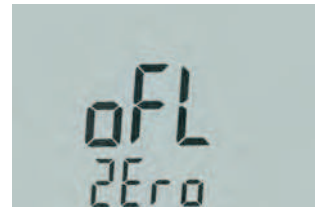

Resetting the zero point correction

The zero point correction stays activated until the device is switched off. After it is switched on again, the zero point correction is no longer activated.

6.3 Functions in the menu for device settings

The following functions can be changed in the "Menu for device settings" (→ § 6.1.1).

- ↵ To do this, keep the MENU button pressed for 2 s.
 - The display shows "Menu".
- ↵ Keep pressing the MENU button until the desired function appears.

Automatic shut-off:

Automatic shut-off is used to extend the battery life.

When the function is activated, the device automatically switches off after 5 minutes. If the function is deactivated, the device is in continuous duty and has to be manually switched off with the ON/OFF button.

The current setting is displayed when the device E2 / D2 is switched on:

- "Po on" = activated (automatic shut-off);
- "Po off" = deactivated (continuous duty).

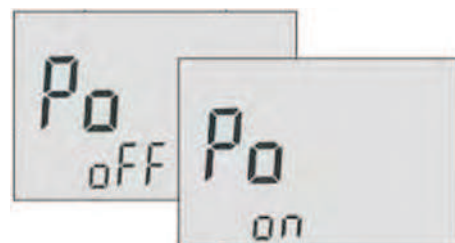

- ↵ Press the MENU button again.
 - The new value of the function is displayed. If the function is already activated "Po off" appears, otherwise "Po on".
- ↵ Press the OK button to save the new value.
 - The selection is saved and the device switches back to measuring mode.



IMPORTANT! The settings are retained after shut-off!

The settings "Po on" or "Po off" are retained and are re-activated when the device is switched on.

Change units:

With the menu item "Unit", you can specify the physical unit of pressure.

- ↵ Keep pressing the MENU button until the menu item "Unit" appears.
 - "Unit" and the first adjustable unit appears (bar). Pressing the MENU button again shows the next adjustable unit. Selectable units: bar, PSI, mbar, kPa, MPa, kg/cm², mH₂O (depending on the pressure range).
- ↵ Select the desired unit with the MENU button and save your selection with the OK button.
 - The selection is saved and the device switches to measuring mode.

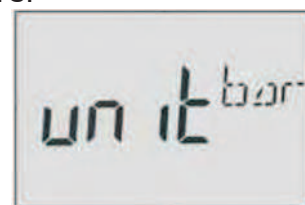

Filter setting (damping):

The menu item "Filt" is used to dampen the display.

↵ Keep pressing the MENU button until the menu item "Filt" appears.

➤ "Filt 0" appears and right of it the current value (--).

Value selection: 0...5 (0 = no damping).

↵ Select the desired value with the MENU button and save your selection with the OK button.

➤ The selection is saved and the device switches back to measuring mode.

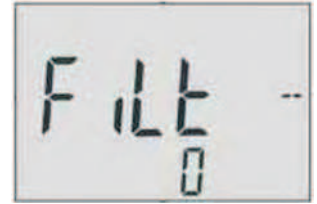
**Displaying the serial number:**

The menu item shows the serial number and the software version of the device. You need this information for questions if servicing work is required.

Furthermore, you can use this item to exit the "Menu for device settings" without making any changes.

↵ Keep pressing the MENU button until the menu item appears.

➤ The serial number and the software version appear:

1st line: Displays the serial number.

2nd line: Displays the software version.

↵ Press the MENU button to stay in the "Menu for device settings".

or

↵ Press the OK button to return to the measuring mode.

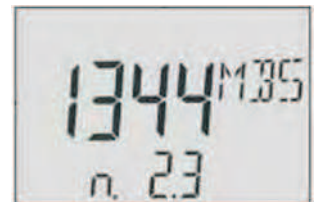

7 Maintenance and cleaning, storage and transport

CAUTION! Material damage and loss of warranty!



If the customer makes changes or intervenes in the device, important parts or components can be damaged.

Such intervention leads to the voiding of any warranty and the manufacturer's responsibility!

✚ Never modify the device or perform any repairs yourself.

Maintenance:

The digital pressure gauge E2 / D2 is maintenance-free and cannot be repaired by the user. In case of a defect, the device must be replaced or returned to the manufacturer for repair.

The only thing that needs to be regularly replaced is the batteries. We recommend replacing them with new ones latest after 1.5 years (→ "replacing the batteries").

Cleaning:

Clean the E2 / D2 with a dry or slightly damp lint-free cloth. Do not use sharp objects or aggressive agents for cleaning.

Storage, transport:

PROCEED CAUTIOUSLY! Electronic Component!



The device contains sensitive electronic components.

✚ Use the original packaging or comparable for transport or shipping.

✚ Avoid shocks and strong vibration.

✚ Protect the device against humidity.



IMPORTANT! Remove the batteries!

If the device will not be used for longer periods, the batteries should be removed from the device to preclude any leaking damage.

8 Disassembly and disposal



CAUTION! Risk of injury!

Never remove the device from a plant in operation.

↪ Make sure that the plant is shut down professionally.

Before disassembly:

Prior to disassembly, ensure that the equipment

- is switched off.
- is in a safe and de-energised state.
- is depressurised and has cooled down.

Disassembly:

- ↪ Watch out for any leaking media. Take appropriate precautions to collect them.
- ↪ Loosen the pressure connection shank with an open-end wrench (WAF 27).
- ↪ Manually turn the E2 / D2 out of the measurement setup.

Disposal:

In conformance with the 2002/95/EC (RoHS) and 2002/96/EC (WEEE) directives, the device must be disposed of as electrical and electronic waste.

Observe the legal regulations of the country in which the device is marketed.



NO HOUSEHOLD WASTE!

The E2 / D2 consists of various different materials. It must not be disposed of with household waste.

- ↪ Take the E2 / D2 to your local recycling plant
- or
- ↪ send the E2 / D2 back to your supplier or to SIKA.



9 Technical data

The technical data of customised versions may differ from the data in these instructions. Please observe the informations specified on the type plate.

Characteristics Reference E2 / D2

Measuring ranges input - Piezzo resistive pressure cell - DMS pressure cell	-1...3 bar -1...40/60 bar and 0...400/700/1000 bar
Accuracy (25°C) - Type E2 - Type D2	0.5% FS ±1 digit 0.1% FS ±1 digit
Sampling rate	10 ms
Internal resolution AD converter	12 bit = 4,096 steps
Temperature influence	0.05% FS / 10 K
Display/ LC Display: - Actual value - MIN/MAX or Full Scale(FS) - Bar graph • Sampling rate - Backlight	4 ½ digits (15 mm) 4 ½ digits (8 mm) 33 segments (drag indicator function) 50 ms (20 measurements /s) 50 x 34 mm
Pressure units	bar, PSI, kPa, MPa, kg/cm ² , mH2O
Electrical characteristics	
Supply voltage	Battery 2 x1.5 VDC AA (LR6 –AA), Alkaline (Mignon)
Battery life	1,500 hrs (without lighting)
Degree of protection (EN 60529)	IP 67
Ambient conditions and process variables	
Operating temperature	0...50 °C
Fluid temperature	-20...+80 °C
Storage temperature	-20...+60 °C
Relative humidity	< 85%
Vibration	IEC 60068-2-6 / 10...500 Hz / 5 g
Shock	IEC 60068-2-29 / 11 msec. / 25 g
Pressure connection: - Material - Connection thread - Gasket	Stainless steel 1.4404 ¼ " BSPP (ISO 1179-2) NBR
Housing: - Material - Dimensions	Zinc cast (Rubber protection cap: TPE) Ø = 79 mm, T = 33 mm
Weight	540 g

Display resolution						
Measuring range	bar (kg/cm ²)	mH ₂ O	PSI	mbar	kPa	MPa
-1...3 bar	-.999...3.000	-10.2...30.6	-15.0...45.0	-999...3000	-100.0...300.0	-/-
-1...40 bar	-1.00...40.00	-10.2...408.2	-15...580	-/-	-100...4000	-0.10...4.00
-1...60 bar	-1.00...60.00	-10.2...612.2	-15...870	-/-	-100...6000	-0.01...6.00
0...400 bar	0.0...400.0	0...4082	0...5800	-/-	0...4000(x10)	0.00...40.00
0...700 bar	0.0...700.0	0...7143	0...10000	-/-	0...7000(x10)	0.00...70.00
0...1000 bar	0.0...1000.0	0...10204	0...14500	-/-	-/-	0.0...100.0



CAUTION! Material damage!

Exceeding the maximum overload values (P_{max}) can lead to malfunctions and result in the digital manometer being destroyed.

Overload values		
Measuring range	Overload	Burst pressure
-1...3 bar	17 bar	20 bar
-1...40 bar	80 bar	400 bar
-1...60 bar	120 bar	550 bar
0...400 bar	800 bar	1700 bar
0...700 bar	1200 bar	2500 bar
0...1000 bar	1500 bar	2500 bar

10 EC Declaration of Conformity

 <p>EG- Konformitätserklärung <i>EC Declaration of Conformity</i></p> <p>Wir erklären, dass die Produkte <i>We declare that the products</i></p> <p>der Baureihe <i>series</i></p> <p>in Verkehr gebracht von <i>placed on the market by</i></p> <p>übereinstimmen mit <i>comply with</i></p> <p>EMV- RL 2004/108/EG</p> <p>EMC-directive</p> <p>DGRL 97/23 EG</p> <p>PED</p> <p>Die Geräte entsprechen folgenden technischen Vorschriften <i>The devices comply with following technical specifications</i></p> <p>DIN EN 61000-6-2:2007</p> <p>DIN EN 61000-6-3:2006</p> <p>Störaussendung für Wohnbereich, Geschäftsbereich und Gewerbebereiche <i>Generic standards - Emission standard for residential, commercial and light-industrial environments</i></p> <p>Kautungen, den 21. Januar 2013</p> <p>i.V.</p> <p>Dipl.- Ing. K. Ulloth <i>(CE- Koordinator und Produktsicherheitsbeauftragter)</i> <i>(Manager CE- Coordination and Safety Supervisor)</i></p> <p><small>SIKA Dr. Siebert & Kühn GmbH & Co. KG - Strothweg 7-9 - D-30262 Kauhagen - Tel. +49 (0) 349 67 80 2-50 - Fax +49 (0) 349 67 80 2-54 - info@sika.de - www.sika.de</small></p> <p><small>CE-00104-06</small></p>	 <p>EG- Konformitätserklärung <i>EC Declaration of Conformity</i></p> <p>Wir erklären, dass die Produkte <i>We declare that the products</i></p> <p>der Baureihe <i>series</i></p> <p>in Verkehr gebracht von <i>placed on the market by</i></p> <p>übereinstimmen mit <i>comply with</i></p> <p>EMV- RL 2004/108/EG</p> <p>EMC-directive</p> <p>DGRL 97/23 EG</p> <p>PED</p> <p>Die Geräte entsprechen folgenden technischen Vorschriften <i>The devices comply with following technical specifications</i></p> <p>DIN EN 61000-6-2:2006</p> <p>DIN EN 61000-6-3:2006</p> <p>Störaussendung für Wohnbereich, Geschäftsbereich und Gewerbebereiche <i>Generic standards - Emission standard for residential, commercial and light-industrial environments</i></p> <p>Kautungen, den 21. Januar 2013</p> <p>i.V.</p> <p>Dipl.- Ing. K. Ulloth <i>(CE- Koordinator und Produktsicherheitsbeauftragter)</i> <i>(Manager CE- Coordination and Safety Supervisor)</i></p> <p><small>SIKA Dr. Siebert & Kühn GmbH & Co. KG - Strothweg 7-9 - D-30262 Kauhagen - Tel. +49 (0) 349 67 80 2-50 - Fax +49 (0) 349 67 80 2-54 - info@sika.de - www.sika.de</small></p> <p><small>CE-00104-06</small></p>
 <p>EG- Konformitätserklärung <i>EC Declaration of Conformity</i></p> <p>Wir erklären, dass die Produkte <i>We declare that the products</i></p> <p>der Baureihe <i>series</i></p> <p>in Verkehr gebracht von <i>placed on the market by</i></p> <p>übereinstimmen mit <i>comply with</i></p> <p>EMV- RL 2004/108/EG</p> <p>EMC-directive</p> <p>DGRL 97/23 EG</p> <p>PED</p> <p>Die Geräte entsprechen folgenden technischen Vorschriften <i>The devices comply with following technical specifications</i></p> <p>DIN EN 61000-6-2:2007</p> <p>DIN EN 61000-6-3:2006</p> <p>Störaussendung für Wohnbereich, Geschäftsbereich und Gewerbebereiche <i>Generic standards - Emission standard for residential, commercial and light-industrial environments</i></p> <p>Kautungen, den 21. Januar 2013</p> <p>i.V.</p> <p>Dipl.- Ing. K. Ulloth <i>(CE- Koordinator und Produktsicherheitsbeauftragter)</i> <i>(Manager CE- Coordination and Safety Supervisor)</i></p> <p><small>SIKA Dr. Siebert & Kühn GmbH & Co. KG - Strothweg 7-9 - D-30262 Kauhagen - Tel. +49 (0) 349 67 80 2-50 - Fax +49 (0) 349 67 80 2-54 - info@sika.de - www.sika.de</small></p> <p><small>CE-00104-06</small></p>	 <p>EG- Konformitätserklärung <i>EC Declaration of Conformity</i></p> <p>Wir erklären, dass die Produkte <i>We declare that the products</i></p> <p>der Baureihe <i>series</i></p> <p>in Verkehr gebracht von <i>placed on the market by</i></p> <p>übereinstimmen mit <i>comply with</i></p> <p>EMV- RL 2004/108/EG</p> <p>EMC-directive</p> <p>DGRL 97/23 EG</p> <p>PED</p> <p>Die Geräte entsprechen folgenden technischen Vorschriften <i>The devices comply with following technical specifications</i></p> <p>DIN EN 61000-6-2:2006</p> <p>DIN EN 61000-6-3:2006</p> <p>Störaussendung für Wohnbereich, Geschäftsbereich und Gewerbebereiche <i>Generic standards - Emission standard for residential, commercial and light-industrial environments</i></p> <p>Kautungen, den 21. Januar 2013</p> <p>i.V.</p> <p>Dipl.- Ing. K. Ulloth <i>(CE- Koordinator und Produktsicherheitsbeauftragter)</i> <i>(Manager CE- Coordination and Safety Supervisor)</i></p> <p><small>SIKA Dr. Siebert & Kühn GmbH & Co. KG - Strothweg 7-9 - D-30262 Kauhagen - Tel. +49 (0) 349 67 80 2-50 - Fax +49 (0) 349 67 80 2-54 - info@sika.de - www.sika.de</small></p> <p><small>CE-00104-06</small></p>

For your notes



Mechanische Messtechnik
Mechanical measuring instruments



Durchflussmesstechnik
Flow measuring instruments



Elektronische Mess- & Kalibriertechnik
Electronic measuring- & calibration instruments



SIKA Dr.Siebert & Kühn GmbH & Co. KG
Struthweg 7-9
D-34260 Kaufungen • Germany

 +49 (0)5605 803-0

 +49 (0)5605 803-54

 info@sika.net

 www.sika.net