

Operating manual Analogue refractometer

**KERN ORA 80 BE Analogue Expert
2x Brix scale**

Version 1.0
01/2015
GB

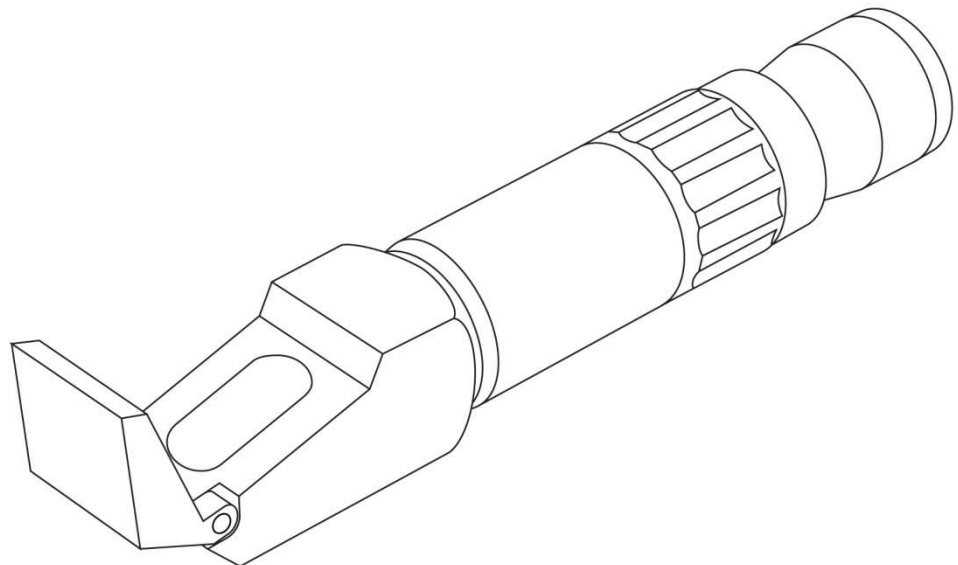



KERN ORA

Version 1.0 01/2015

Operating instructions

Analogue refractometer

Contents

1	Technical data	3
2	Description	4
3	General information	5
3.1	Intended use	5
3.2	Warranty	5
4	Basic safety information	6
4.1	Follow the instructions in the operating manual	6
4.2	Warning	6
5	Supplied items	7
6	Before the first use	7
7	Use/measurement	7
7.1	Zero point calibration	8
7.2	Additional advice	9
7.3	Measuring procedure	9
8	Cleaning and maintenance	10
9	Storage	10
10	Service	10
11	Disposal	10
12	Additional information	10
13	Brix to refractive index (nD) conversion table	10
14	Annex	1

1 Technical data

Models KERN	Measuring range and Scales	Scale gradua- tions Accuracy	Dimensions Product	Net weight
ORA 80BE	Brix: 0-50% Brix: 50-80%	0.5% Brix 0.5% Brix	180x40x40mm	0.400 kg

Example scale on the ORA 80 BE

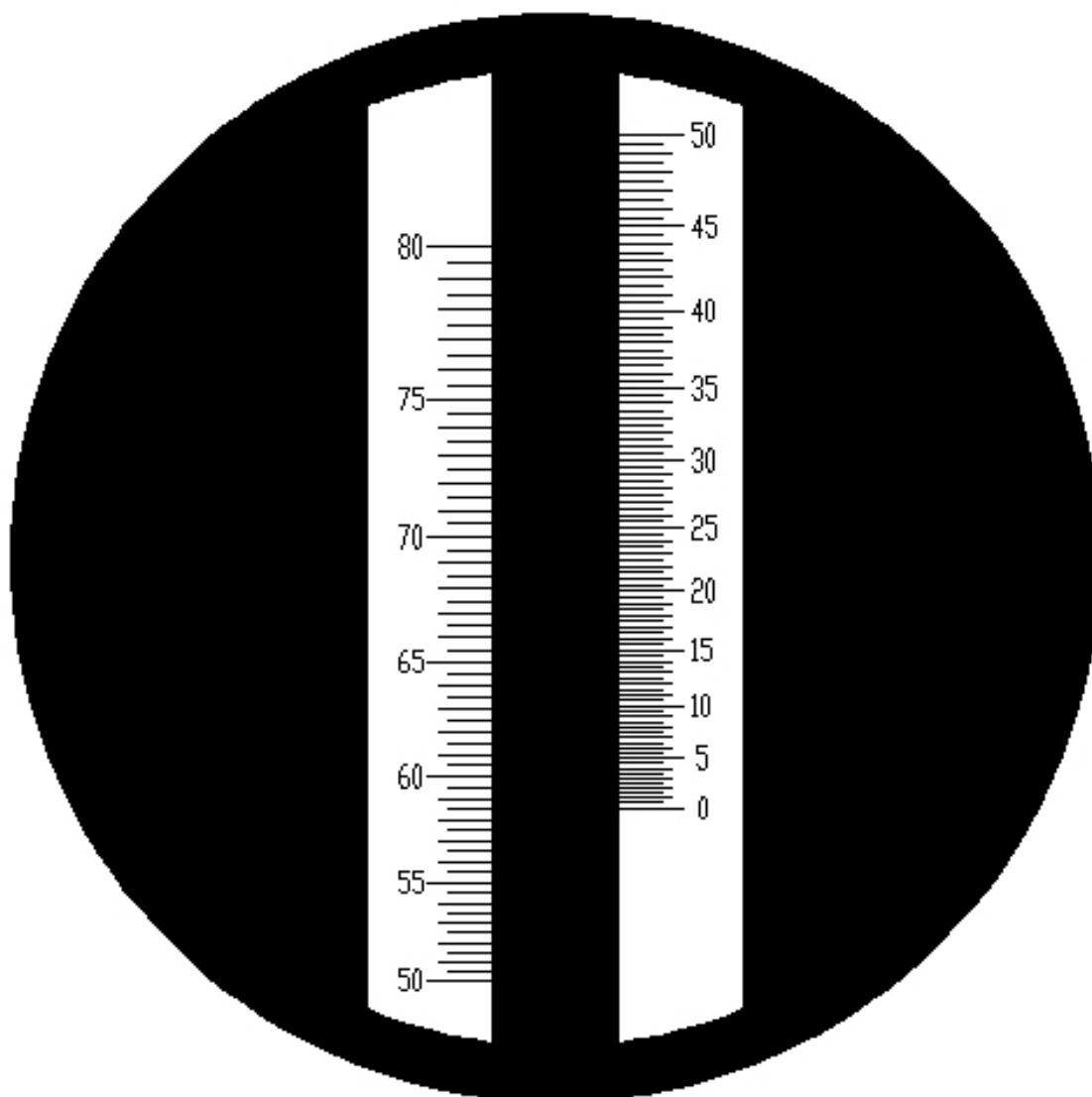

2 Description

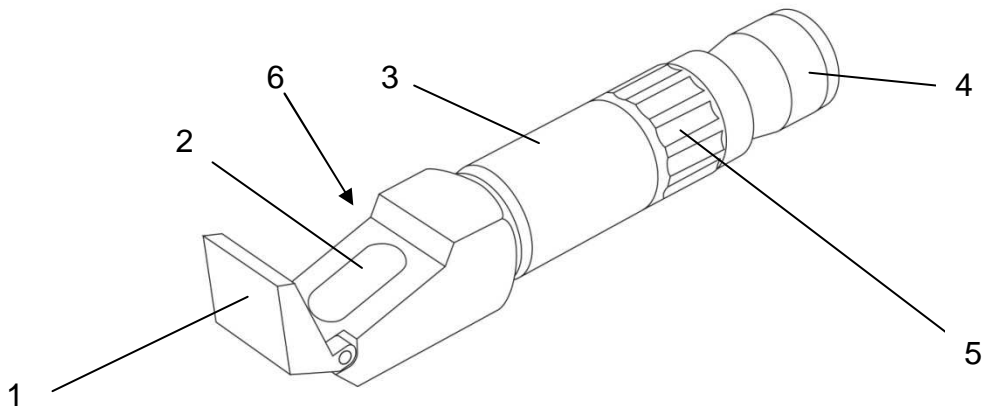

1. Prism cover
2. Prism surface
3. Optical tubes with grip
4. Eyepiece with dipter adjustment ring
5. Adjusting wheel measuring range
6. Adjusting screw

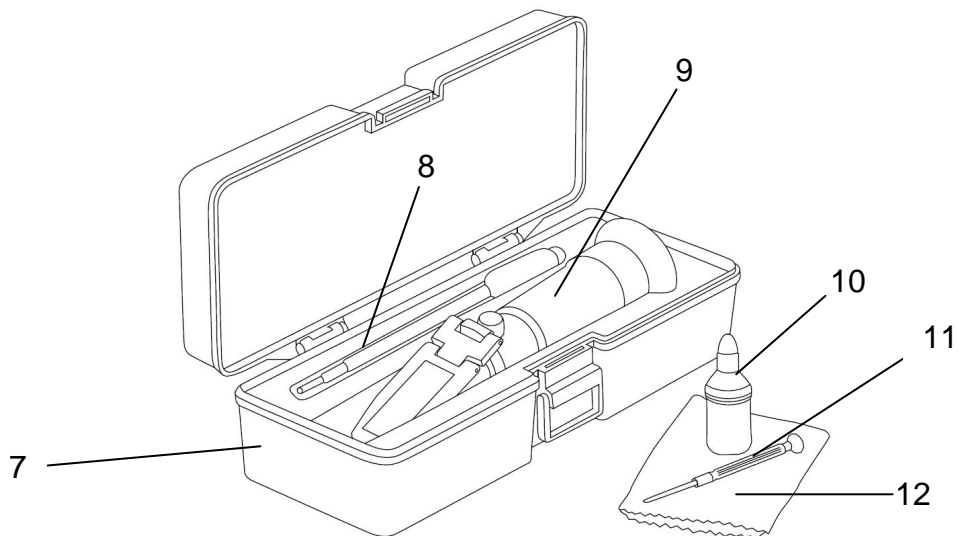

7. Storage box
8. Pipette
9. Refractometer
10. Distilled water / calibration liquid
11. Tools
12. Cleaning cloth

3 General information

3.1 Intended use

The refractometer is a measuring instrument for determining the refractive index of transparent substances in liquid or in some cases also in the solid state. It is used to observe the behaviour of light as it passes from a prism with known properties to the substance being tested.

Use of the refractometer for other purposes is contrary to its intended use and may be hazardous. The manufacturer shall not be liable for any damages caused by improper use.

3.2 Warranty

The warranty shall be void in the event of:

- ⇒ Failure to observe the instructions in the operating manual
- ⇒ Use for purposes other than those described
- ⇒ Modifications or opening the device housing
- ⇒ Mechanical damage and/or damage resulting from media, liquids, natural wear and tear

4 Basic safety information

4.1 Follow the instructions in the operating manual



- ⇒ Carefully read through the operating manual even if you have prior experience with KERN refractometers.
- ⇒ Every language version includes a non-authoritative translation. The original German document is the definitive version.

4.2 Warning

- ⇒ Do not let acids come into contact with skin or eyes. If acid comes into contact with skin, flush with copious amounts of water. Shower if larger areas of skin are affected.
- ⇒ If acid comes into contact with eyes, keep the eyelid open and flush the eye with running lukewarm water from the outer corner to the inner corner. Flush eyes for at least 15 minutes. Then consult a doctor or ophthalmologist immediately.
- ⇒ Thoroughly clean the refractometer after each use.
- ⇒ The refractometer must not be exposed to extreme temperatures, high mechanical stresses, strong direct sunlight or high humidity.
- ⇒ This refractometer is not a toy. Keep out of reach of children.
- ⇒ Make sure that you will not be hit by anything else while you are using the refractometer, as this could cause serious eye injuries
- ⇒ The rubber eyeshade may cause irritation when in prolonged contact with the skin. If this happens, consult your doctor.
- ⇒ Do not touch the lenses with your fingers.

5 Supplied items

After unpacking and before using the device for the first time, check that all listed parts have been supplied. Replace damaged or faulty parts immediately and do not put them into operation.

- ⇒ Refractometer
- ⇒ Storage box
- ⇒ Pipette
- ⇒ Adjustment tool
- ⇒ Cleaning cloth
- ⇒ Distilled water/calibration liquid

6 Before the first use

Remove the protective film (if present) from the prism surface [2] and check that the rubber eye-cup [4] is fitted correctly.

7 Use/measurement

The refractometer can be used to quickly and accurately determine the refractive index of transparent substances, liquid or solid ones. To ensure correct measurement, the measuring device should be adjusted before measurements are carried out. Please make sure your hands are dry before handling the measuring device.

The measuring instrument has two measuring ranges. To switch between the two measuring ranges rotate the housing ring [5] between the eyepiece [4] and the optical tube [3].

7.1 Zero point calibration

- ⇒ Hold up the refractometer against a sufficiently bright light source and look through the eyepiece [4], holding the eyepiece closely against your eye/glasses.
- ⇒ Rotate the eyepiece [4] to adjust it for your eyesight, until you can see the scale sharply.
- ⇒ Open the prism cover [1].
- ⇒ Thoroughly clean the prism [2] and the underside of the prism cover [1] using a soft cloth or soft paper (with alcohol if necessary) and wipe dry. Water should only ever be applied to the measuring prism, not to other parts of the device.
- ⇒ Now apply a few drops of the calibration liquid [10] onto the prism surface [2].
- ⇒ close the prism cover [1]. The amount of fluid should be sufficient to moisten most of the prism surface. There should not be any air bubbles between the measuring prism [2] and prism cover [1].
- ⇒ Wait about 30 seconds to allow the temperatures of the test fluid and prism to equalise.
- ⇒ Look through the eyepiece [4] while pointing the refractometer's prism surface [2] at a bright light source.
- ⇒ Through the eyepiece [4], you will see a bright and a blue field. The boundary line between them shows the refractive index value on the scale which is also visible through the eyepiece [4].
- ⇒ With the aid of the supplied adjustment tool [11] to turn the adjustment screw [3] at the side of the prism surface [2] the scale can be adjusted so that the measuring device is optimally set up. The bright/dark boundary line should be at 0% Brix. For refractometers which are not adjusted at 0% Brix using distilled water and have a special calibration liquid, set the bright/dark boundary line to the calibration line in the field of view. The room temperature must be +20 °C.
- ⇒ For refractometers without automatic temperature compensation (ATC): Convert the measured value to take account of the deviation in room and sample temperature from +20 °C. (See the table at the end of this manual, Point 13.)
- ⇒ Repeat step 4 (cleaning).

Important!



The ambient/room temperature and the sample temperature influence the refractometer measuring result.

The scales are designed for an ambient temperature of +20 °C!

If the measurements are carried out at a temperature other than +20 °C, the results must be correspondingly corrected.

A correction table can be found in the annex, Point 13.

7.2 Additional advice

It is important that the samples being measured are representative samples. Measurements should be carried out quickly on samples that evaporate easily. If possible, the samples should be at the same temperature as the measuring instrument in order to achieve an accurate result.

7.3 Measuring procedure

- ⇒ Make sure your hands are dry before handling the refractometer.
- ⇒ Open the prism cover [1] and use the supplied pipette [8] to apply a few drops of the sample liquid [8] onto the prism surface [2], then close the prism cover [1]. Spread the liquid evenly by pressing down on the prism cover [1] and eliminate any air bubbles present.
- ⇒ Hold the device horizontally and wait about 30 seconds (for optimal temperature equalisation between the sample and device).
- ⇒ View the measurement scale through the eyepiece [4]. Point the prism surface [2] of the refractometer at a bright light source while doing this.
- ⇒ Rotate the adjustment ring [5] on the eyepiece [4] to adjust the focus.
- ⇒ The boundary line will move on the measurement scale depending on the concentration. This bright/dark boundary line shows the result directly on the scale.
- ⇒ If the temperature deviates from +20 °C, correct the measured result using the corresponding value from the temperature correction table [13].
- ⇒ Carefully clean the supplied pipette [8] and the refractometer after carrying out the measurement.

Important!



After every measurement, use a lint-free, absorbent cloth to remove the fluids from the prism surface [2] and prism cover [1]. Then carefully clean the prism and prism cover using a cloth moistened with water and dry both parts using a soft, dry and lint-free cloth. Avoid rubbing the prism [2].

8 Cleaning and maintenance

Clean the refractometer using a soft, lint-free cloth moistened with water, or if necessary alcohol. Do not use any aggressive or abrasive cleaning agents. Never immerse the device in water or hold it under running water. Never handle the device with wet or damp hands.

Never touch the measuring prism [2] with hard tools made from plastic, wood, rubber, metal, glass etc. Hard objects can quickly damage the relatively soft prism glass, resulting in measurement errors.

The refractometer is maintenance-free.

Cleaning should be carried out immediately before and after each use of the refractometer to maximise its life and optimise measurement results.

9 Storage

Store the refractometer in a dry, non-corrosive environment, preferably between 10 °C and 30 °C.

10 Service

After reading this operating manual, if you have any questions about setting up or using the refractometer, or if any unexpected problem occurs, please contact your dealer. The device housing may only be opened by trained service technicians authorised by KERN.

11 Disposal

The packaging consists of environmentally friendly materials which can be disposed of via local recycling facilities.

The device and storage box should be disposed of by the operator in accordance with applicable national or regional regulations at the place of use.

12 Additional information

The product may differ slightly from the illustrations.
Avoid exposing the refractometer to direct sunlight.
Never bring the refractometer into contact with solvents.

13 Brix to refractive index (nD) conversion table

BRIX	Refractive	BRIX	Refractive	BRIX	Refractive
------	------------	------	------------	------	------------

index		index		index	
%	nD	%	nD	%	nD
0	1.33299	30	1.38115	60	1.44193
1	1.33442	31	1.38296	61	1.44420
2	1.33586	32	1.38478	62	1.44650
3	1.33732	33	1.38661	63	1.44881
4	1.33879	34	1.38846	64	1.45113
5	1.34026	35	1.39032	65	1.45348
6	1.34175	36	1.39220	66	1.45584
7	1.34325	37	1.39409	67	1.45822
8	1.34476	38	1.39600	68	1.46061
9	1.34629	39	1.39792	69	1.46303
10	1.34782	40	1.39986	70	1.46546
11	1.34937	41	1.40181	71	1.46792
12	1.35093	42	1.40378	72	1.47037
13	1.35250	43	1.40576	73	1.47285
14	1.35408	44	1.40776	74	1.47535
15	1.35568	45	1.40978	75	1.47787
16	1.35729	46	1.41181	76	1.48040
17	1.35891	47	1.41385	77	1.48295
18	1.36054	48	1.41592	78	1.48552
19	1.36218	49	1.41799	79	1.4881
20	1.36384	50	1.42009	80	1.49071
21	1.36551	51	1.42220	81	1.49333
22	1.36720	52	1.42432	82	1.49597
23	1.36889	53	1.42647	83	1.49862
24	1.37060	54	1.42862	84	1.50129
25	1.37233	55	1.43080	85	1.50398
26	1.37406	56	1.43299		
27	1.37582	57	1.43520		
28	1.37758	58	1.43743		
29	1.37936	59	1.43967		

Data from "ICUMSA" International Commission for Uniform Methods of Sugar Analysis, at 20 °C and 589 nm wavelength.

14 Annex

Table 1: International Temperature Correction Table for °Brix (% sugar gradient)

Correct the result by the following values (refractometer must be correctly calibrated at 20 °C)

		% Brix reading		10.0	15.0	20.0	25.0	30.0	35.0	40.0	45.0	50.0	55.0	60.0	65.0	70.0	75.0	80.0	85.0	
		0.0	5.0																	
Temperature °C	10.0	-0.53	-0.56	-0.59	-0.62	-0.65	-0.67	-0.69	-0.71	-0.72	-0.73	-0.74	-0.75	-0.75	-0.75	-0.75	-0.75	-0.74	-0.73	
	11.0	-0.49	-0.52	-0.54	-0.57	-0.59	-0.61	-0.63	-0.64	-0.65	-0.66	-0.67	-0.68	-0.68	-0.68	-0.68	-0.67	-0.67	-0.66	
	12.0	-0.44	-0.47	-0.49	-0.51	-0.53	-0.55	-0.56	-0.57	-0.58	-0.59	-0.60	-0.60	-0.61	-0.61	-0.60	-0.60	-0.60	-0.59	
	13.0	-0.40	-0.41	-0.43	-0.45	-0.47	-0.48	-0.50	-0.51	-0.52	-0.52	-0.53	-0.53	-0.53	-0.53	-0.53	-0.53	-0.53	-0.52	-0.52
	14.0	-0.34	-0.36	-0.38	-0.39	-0.40	-0.42	-0.43	-0.44	-0.44	-0.45	-0.45	-0.46	-0.46	-0.46	-0.46	-0.46	-0.45	-0.45	-0.44
	15.0	-0.29	-0.31	-0.32	-0.33	-0.34	-0.35	-0.36	-0.37	-0.37	-0.38	-0.38	-0.38	-0.38	-0.38	-0.38	-0.38	-0.38	-0.37	-0.37
	16.0	-0.24	-0.25	-0.26	-0.27	-0.28	-0.28	-0.29	-0.30	-0.30	-0.30	-0.31	-0.31	-0.31	-0.31	-0.31	-0.31	-0.30	-0.30	-0.30
	17.0	-0.18	-0.19	-0.20	-0.20	-0.21	-0.21	-0.22	-0.22	-0.23	-0.23	-0.23	-0.23	-0.23	-0.23	-0.23	-0.23	-0.23	-0.23	-0.22
	18.0	-0.12	-0.13	-0.13	-0.14	-0.14	-0.14	-0.15	-0.15	-0.15	-0.15	-0.15	-0.15	-0.15	-0.15	-0.15	-0.15	-0.15	-0.15	-0.15
	19.0	-0.06	-0.06	-0.07	-0.07	-0.07	-0.07	-0.07	-0.08	-0.08	-0.08	-0.08	-0.08	-0.08	-0.08	-0.08	-0.08	-0.08	-0.08	-0.07
	20.0	0.00	0.00	0.00	0.00	0.00	0.00	0.00	0.00	0.00	0.00	0.00	0.00	0.00	0.00	0.00	0.00	0.00	0.00	0.00
	21.0	0.06	0.07	0.07	0.07	0.07	0.07	0.08	0.08	0.08	0.08	0.08	0.08	0.08	0.08	0.08	0.08	0.08	0.08	0.07
	22.0	0.13	0.14	0.14	0.14	0.15	0.15	0.15	0.15	0.16	0.16	0.16	0.16	0.16	0.16	0.16	0.15	0.15	0.15	0.15
	23.0	0.20	0.21	0.21	0.22	0.22	0.23	0.23	0.23	0.23	0.24	0.24	0.24	0.24	0.23	0.23	0.23	0.23	0.23	0.22
	24.0	0.27	0.28	0.29	0.29	0.30	0.30	0.31	0.31	0.31	0.32	0.32	0.32	0.32	0.31	0.31	0.31	0.31	0.30	0.30
	25.0	0.34	0.35	0.36	0.37	0.38	0.38	0.39	0.39	0.40	0.40	0.40	0.40	0.40	0.39	0.39	0.39	0.39	0.38	0.37
	26.0	0.42	0.43	0.44	0.45	0.46	0.46	0.47	0.47	0.48	0.48	0.48	0.48	0.48	0.47	0.47	0.47	0.46	0.46	0.46
	27.0	0.50	0.51	0.52	0.53	0.54	0.55	0.55	0.56	0.56	0.56	0.56	0.56	0.56	0.55	0.55	0.55	0.54	0.53	0.52
	28.0	0.58	0.59	0.60	0.61	0.62	0.63	0.64	0.64	0.64	0.65	0.65	0.64	0.64	0.64	0.63	0.62	0.61	0.60	0.60
	29.0	0.66	0.67	0.68	0.69	0.70	0.71	0.72	0.73	0.73	0.73	0.73	0.73	0.72	0.72	0.71	0.70	0.69	0.68	0.68
30.0	0.74	0.75	0.77	0.78	0.79	0.80	0.81	0.81	0.81	0.82	0.81	0.81	0.81	0.80	0.79	0.78	0.77	0.75	0.75	