

We measure it.



# The Professional's Choice Infrared Thermometer

testo 830 - Quickly measure  
surface temperatures

---

Exact laser sighting and large optics for precision  
measurements at long distances

---

Two readings per second

---

Adjustable emissivity

---

Two adjustable alarm limit values

---

Ergonomic, comfortable pistol grip design

---

Hold function and display of min/max values

---



Measure surface temperatures quickly and easily with little effort using the testo 830 series infrared thermometers - ideal for industrial and trade industries. The 830 series has just been optimized with a new processor providing higher resolution of 0.1 °F and improved accuracy. Convenient features like min/max function, hold, backlit display and adjustable alarms make it the perfect tool for everyday use.

Four feature packed models to choose from:

**testo 830-T1** with 1-point laser; 10:1 optics.

**testo 830-T2** with 2-point laser; 12:1 optics.

**testo 830-T3** with 2-point laser; close focus optics

**testo 830-T4** with 2-point laser; 30:1 optics

[www.testo.com](http://www.testo.com)

# Infrared thermometers

## testo 830

### Infrared thermometer with 1-point laser sighting

#### testo 830-T1

testo 830-T1, infrared thermometer, 1 point laser sighting, 10:1 optics, adjustable alarm values, alarm function, incl. batteries and factory calibration certificate

Part no. 0560 8311



### Infrared thermometer with 2-point laser sighting and type K t/c probe input

#### testo 830-T2

testo 830-T2, infrared thermometer, 2-point laser sighting, 12:1 optics, adjustable alarm values, alarm function, optional external probes, incl. batteries and factory calibration certificate

Part no. 0560 8312



The ultra-fast, universal infrared thermometer with 1-point laser sighting and 10:1 optics and ergonomic "pistol grip design".

- Quick readings
- Laser sighting
- Adjustable alarm values
- Audible and optical alarm when limit values are exceeded
- Comfortable "pistol grip design"
- Backlit display
- Adjustable emissivity factor (0.1 to 1.0)

#### testo 830-T2 Kit

Kit 830-T2, infrared thermometer with protective leather case, incl. cross-band surface probe, batteries and factory calibration certificate

Part no. 0563 8312

The fastest and most versatile infrared thermometer with two point laser sighting and 12:1 optics. Optional external Type K probe available for direct measurements.

All the benefits of testo 830-T1 PLUS:

- Two point laser sighting
- Optional external thermocouple probes
- Emissivity test with external thermocouple probe

# Infrared thermometers

## testo 830

### Infrared thermometer with close focus optics for measuring small objects

#### testo 830-T3

testo 830-T3, infrared thermometer with close focus optics, 2-point laser sighting, adjustable alarm values, alarm function, contact temperature probe, batteries and factory calibration certificate

Part no. 0560 8303



The fastest infrared thermometer, testo 830-T3 is ideal for measuring temperature on objects or areas with a very small surface diameter. A two-point laser marks the measurement point exactly.

- Small measurement point of 0.07", at 1" away
- °F contact measurement with attachable t/c probe
- Backlit display
- Audible and optical alarm when limit values are exceeded
- Adjustable emissivity (0.1 to 1.0)

### Infrared thermometer with 30:1 optics for exact measurement at a distance

#### testo 830-T4

testo 830-T4, infrared thermometer, 2-point laser sighting, 30:1 optic, adjustable alarm values, alarm function, external probe connections, incl. batteries and factory calibration certificate

Part no. 0560 8314



#### testo 830-T4 Kit

Kit 830-T4, infrared thermometer with protective leather case, incl. cross-band surface probe, battery and factory calibration certificate

Part no. 0563 8314

Extremely precise infrared thermometer with two point laser sighting and 30:1 optics. Able to measure the smallest surface diameter in almost any area or on any object. The diameter of the measurement spot is only 1.4 inches at a distance of three feet. Accepts external temperature probes.

- 30:1 optics for measuring temperature at a distance, even on small objects
- °F contact measurement with connecting TC probe
- Emissivity testing with external temperature probe
- Input of upper and lower limit value
- Audible and optical alarm when limit values are exceeded
- Backlit display

## Technical data

### Common technical data for all versions

Spectral range	8 to 14 $\mu\text{m}$	Battery type	9V battery
Emissivity	Adjustable 0.1	Battery life	15 hrs
Storage temp.	-40 to +158 $^{\circ}\text{F}$	Weight	7.05 ozs.
Oper. temp.	-4 to +50 $^{\circ}\text{F}$	Dimensions	7.5 x 2.3 x 1.5 in
		Material/Housing	ABS

### Technical data

	testo 830-T1	testo 830-T2	testo 830-T3	testo 830-T4
<b>Meas. range</b>				
Infrared	-8 to +752 $^{\circ}\text{F}$	-8 to +752 $^{\circ}\text{F}$	-25 to +752 $^{\circ}\text{F}$	-8 to +752 $^{\circ}\text{F}$
Type K (NiCr-Ni)	-	-58 to +932 $^{\circ}\text{F}$	-58 to +932 $^{\circ}\text{F}$	-58 to +932 $^{\circ}\text{F}$
<b>Accuracy <math>\pm 1</math> digit</b>				
Infrared	$\pm 1.5$ $^{\circ}\text{F}$ or 1.5 % of rdg (+0.1 to +752 $^{\circ}\text{F}$ ) $\pm 2$ $^{\circ}\text{F}$ or $\pm 2$ % of rdg (-8 to 32 $^{\circ}\text{F}$ ) the higher value applies	$\pm 1.5$ $^{\circ}\text{F}$ or $\pm 1.5$ % of rdg (+32 to +752 $^{\circ}\text{F}$ ) $\pm 2$ $^{\circ}\text{F}$ or $\pm 2$ % of rdg (-8 to 32 $^{\circ}\text{F}$ ) the higher value applies	$\pm 1$ $^{\circ}\text{F}$ (-4 to +212 $^{\circ}\text{F}$ ) $\pm 2$ $^{\circ}\text{F}$ or $\pm 2$ % of rdg (remaining range)	$\pm 1.5$ $^{\circ}\text{F}$ (-4 to 32 $^{\circ}\text{F}$ ) $\pm 2$ $^{\circ}\text{F}$ (-8 to -4.1 $^{\circ}\text{F}$ ) $\pm 1$ $^{\circ}\text{F}$ or 1% of rdg (remaining range)
Type K (NiCr-Ni)	-	$\pm 0.5$ $^{\circ}\text{F}$ +0.5% of rdg	$\pm 0.5$ $^{\circ}\text{F}$ +0.5% of rdg	$\pm 0.5$ $^{\circ}\text{F}$ +0.5% of rdg
<b>Resolution</b>	0.1 $^{\circ}\text{F}$	0.1 $^{\circ}\text{F}$	0.5 $^{\circ}\text{F}$	0.1 $^{\circ}\text{F}$
<b>Measurement rate</b>				
Infrared	0.5 sec	0.5 sec	0.5 sec	0,5 sec
Type K (NiCr-Ni)	-	1.75 sec	1.75 sec	1.75 sec
<b>Laser spot</b>	1-point laser	2-point laser	2-point laser	2-point laser
<b>Distance to measurement spot</b>	10:1	12:1	2.5:1 0/1" @ 1 in. (90%)	30:1 (typical at a distance of 0.03 in to the measurement object 1 in @ 28 in (90%))

# Optics

**10:1 standard optics,  
1 laser beam sighting**

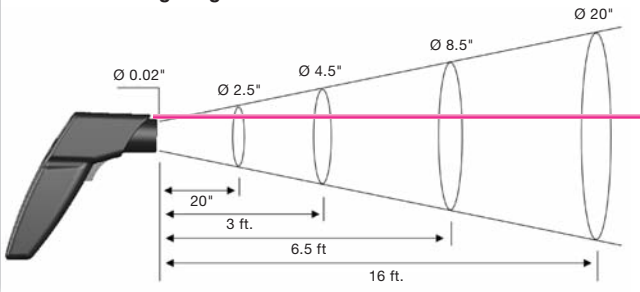

**Accurate 12:1 optics enable accurate measurements over great distances, 2 laser beams for sighting**

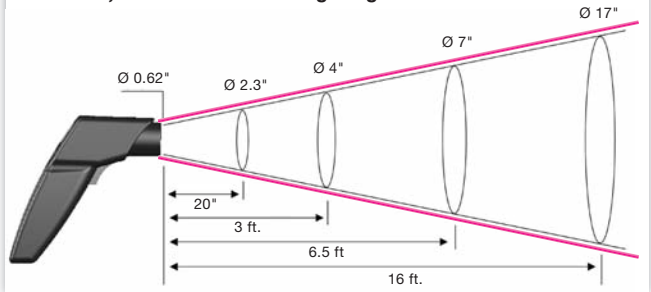

**Small measurement point of 0.07 inches, distance 1 inch, 2 laser beams for sighting**

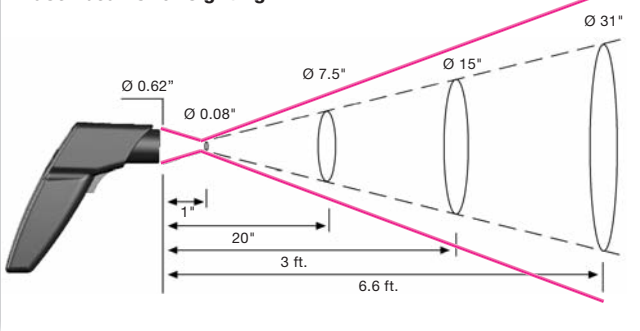

**Distance to measurement spot 30:1, 2 laser beams for sighting**

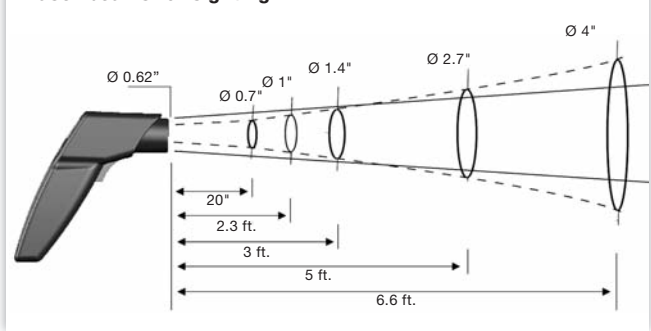







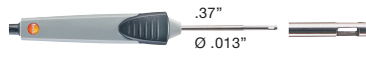

# Accessories

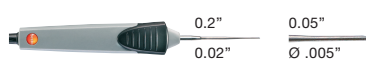
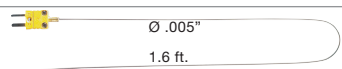
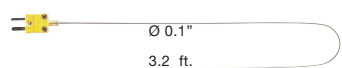
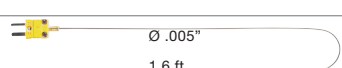
Accessories for all testo 830 versions	Part no.
Adhesive tape for bare surfaces (roll, L.: 32 ft., W.: 1 in.), E = 0.95, temperature resistant to +482 °F	0554 0051
Leather case to protect instrument, with belt holder	0516 8302
9V rech. battery for instrument	0515 0025
Recharger for 9V rechargeable battery, for external recharging of battery (part no: 0515 0025)	0554 0025
ISO calibration certificate/temperature, infrared thermometer; calibration points +140°F; +248°F; +356°F	0520 0002

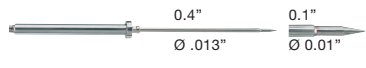

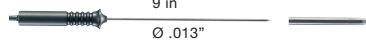

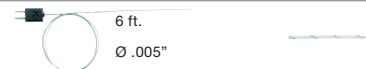





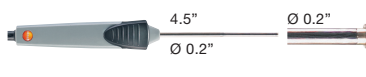

# Probes

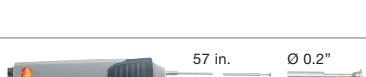
## 830-T2 / -T3 / -T4

Probe type	Dimensions Probe shaft/probe shaft tip	Measuring range	Accuracy	Sec	Part no.
<b>Air probes</b>					
Rugged air probe, T/C Type K, Fixed cable 4 in	 .37" Ø .013"	-76 to +752 °F	Class 2*	25 s	0602 1793
<b>Immersion/penetr. probes</b>					
Efficient and fast-action immersion probe, waterproof, TC Type K, Fixed cable 4 in	 0.98" Ø .005"	-76 to +1832 °F	Class 1*	2 s	0602 0593
Fast-action, waterproof immersion/penetration probe, TC Type K (Calibration not possible over +300 °F), Fixed wire 4 in	 0.2" 0.02" 0.05" Ø .005"	-76 to +1472 °F	Class 1*	3 s	0602 2693
Immersion tip, flexible, TC Type K	 Ø .005" 1.6 ft.	-328 to +1832 °F	Class 1*	5 s	0602 5792
Immersion measurement tip, flexible, for measurements in air/exhaust gases (not suitable for measurements in smelters), TC Type K	 Ø 0.1" 3.2 ft.	-328 to +2372 °F	Class 1*	4 s	0602 5693
Immersion tip, flexible, TC Type K	 Ø .005" 1.6 ft.	-328 to +104 °F	Class 3*	5 s	0602 5793
Waterproof immersion/penetration probe, TC Type K, Fixed cable 4 in	 .37" 0.16" 0.02" Ø 0.012"	-76 to +752 °F	Class 2*	7 s	0602 1293
<b>Food probes</b>					
Waterproof food probe made of stainless steel (IP65), TC Type K, Fixed wire	 0.4" 0.1" Ø .013" Ø 0.01"	-76 to +752 °F	Class 2*	7 s	0602 2292
Rugged food probe with special handle, IP 65, reinforced cable (PUR), T/C Type K, Fixed wire	 .37" 0.1" 0.02" Ø 0.01"	-76 to +752 °F	Class 1*	6 s	0602 2492
Waterproof rugged immersion/penetration probe with metal protection hose Tmax +446 °F, i.e for monitoring temp. in cooking oil, T/C Type K, Fixed cable	 9 in Ø .013"	-58 to +446 °F	Class 1*	15 s	0628 1292
<b>Thermocouples</b>					
Thermocouple with TC adapter, flexible, 2.6 ft. long, fiber glass, TC Type K	 32" Ø .005"	-58 to +752 °F	Class 2*	5 s	0602 0644
Thermocouple with TC adapter, flexible, 6 ft. long, fiber glass, TC Type K	 6 ft. Ø .005"	-58 to +752 °F	Class 2*	5 s	0602 0645
Thermocouple with TC adapter, flexible, 6 ft. long, PTFE, TC Type K	 6 ft. Ø .005"	-58 to +482 °F	Class 2*	5 s	0602 0646

\*According to standard EN 60584-2, the accuracy of Class 1 refers to -40 to +1832 °F (Type K), Class 2 to -40 to +2192 °F (Type K), Class 3 to -40 to +104 °F (Type K)

# Probes testo 830-T2 / -T3 / -T4

Probe type	Dimensions Probe shaft/probe shaft tip	Measuring range	Accuracy	Sec	Part no.
<b>Surface probes</b>					
Fast-reaction paddle surface probe, for measurements in narrow apertures and slots, TC Type K, Fixed cable		32 to +572 °F	Class 2*	5 s	0602 0193
Fast-action surface probe with spring thermocouple strip, also for uneven surfaces, measurement range short-term to +932 °F, TC Type K, Fixed cable 4 in		-76 to +572 °F	Class 2*	3 s	0602 0393
Waterproof surface probe with widened measurement tip for flat surfaces, T/C Type K, Fixed cable 4 in		-76 to +752 °F	Class 2*	30 s	0602 1993
Fast-action surface probe with spring thermocouple strip, bent, also for uneven surfaces, measurement range short-term to +932 °F, TC Type K, Fixed cable 4 in		-76 to +572 °F	Class 2*	3 s	0602 0993
Efficient, waterproof surface probe with small measurement head for flat surfaces, TC Type K, Fixed cable 4 in		-76 to +1832 °F	Class 1*	20 s	0602 0693
Flat head surface probe with telescopic handle max. 2 ft. for measurements at hard-to-access points, TC Type K, Fixed cable, 5 ft. (correspondingly shorter when telescope extended)		-58 to +482 °F	Class 2*	3 s	0602 2394
Magnetic probe, adhesive force approx. 20 N, with magnets, for measurements on metal surfaces, TC Type K, Fixed wire		-58 to +338 °F	Class 2*	150 s	0602 4792
Magnetic probe, adhesive force approx. 10 N, with magnets, for higher temp., for measurements on metal surfaces, TC Type K, Fixed wire		-58 to +752 °F	Class 2*		0602 4892
Pipe wrap probe with velcro strip; for temperature measurement on pipes with diameter up to max. 5 in.; Tmax. +248 °F; TC Type K, Fixed wire		-58 to +248 °F	Class 1*	90 s	0628 0020
Pipe wrap probe for pipe diameter 0.2 to 3" , with exchangeable measuring head. Meas. range short-term to +536 °F, TC Type K, Fixed wire		-76 to +226 °F	Class 2*	5 s	0602 4592
Spare meas. head for pipe wrap probe, TC Type K		-76 to +226 °F	Class 2*	5 s	0602 0092
Clamp probe for measurements on pipes, pipe diameter 0.6 to 1" (max. 1"), meas. range short-term up to +572 °F, TC Type K, Fixed wire		-58 to +212 °F	Class 2*	5 s	0602 4692

\*According to standard EN 60584-2, the accuracy of Class 1 refers to -40 to +1832 °F (Type K), Class 2 to -40 to +2192 °F (Type K), Class 3 to -40 to +104 °F (Type K)



0986 9373/dk/A/04.2012

Testo Inc  
40 White Lake Rd.  
Sparta, NJ 07871  
800-227-0729  
Fax: 862-354-5020  
email: info@testo.com

**[www.testo.com](http://www.testo.com)**

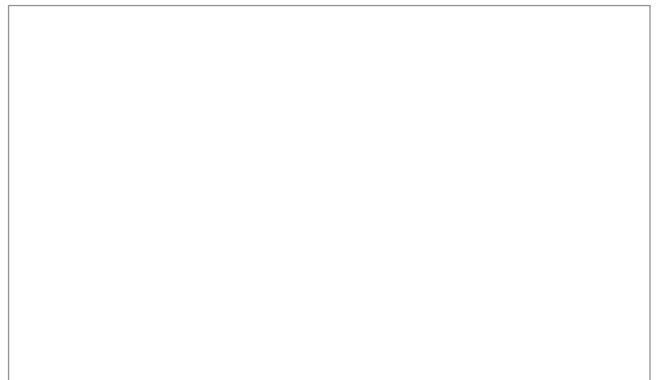

Subject to change without notice.