

**ROBIN**  **AMPROBE®**

**KMP 7036**

**Insulation-Continuity Tester**

**Users Manual**





# **KMP7036**

## **Insulation-Continuity Tester**

### **Users Manual**

**English**

September 2011, Rev.1  
©2011 Amprobe Test Tools.  
All rights reserved. Printed in China

### **Limited Warranty and Limitation of Liability**

Your Amprobe product will be free from defects in material and workmanship for 1 year from the date of purchase, unless local laws require otherwise. This warranty does not cover fuses, disposable batteries or damage from accident, neglect, misuse, alteration, contamination, or abnormal conditions of operation or handling. Resellers are not authorized to extend any other warranty on Amprobe's behalf. To obtain service during the warranty period, return the product with proof of purchase to an authorized Amprobe Test Tools Service Center or to an Amprobe dealer or distributor. See Repair Section for details. THIS WARRANTY IS YOUR ONLY REMEDY. ALL OTHER WARRANTIES - WHETHER EXPRESS, IMPLIED OR STATUTORY - INCLUDING IMPLIED WARRANTIES OF FITNESS FOR A PARTICULAR PURPOSE OR MERCHANTABILITY, ARE HEREBY DISCLAIMED. MANUFACTURER SHALL NOT BE LIABLE FOR ANY SPECIAL, INDIRECT, INCIDENTAL OR CONSEQUENTIAL DAMAGES OR LOSSES, ARISING FROM ANY CAUSE OR THEORY. Since some states or countries do not allow the exclusion or limitation of an implied warranty or of incidental or consequential damages, this limitation of liability may not apply to you.

### **Repair**

All test tools returned for warranty or non-warranty repair or for calibration should be accompanied by the following: your name, company's name, address, telephone number, and proof of purchase. Additionally, please include a brief description of the problem or the service requested and include the test leads with the meter. Non-warranty repair or replacement charges should be remitted in the form of a check, a money order, credit card with expiration date, or a purchase order made payable to Amprobe® Test Tools.

### **In-Warranty Repairs and Replacement – All Countries**

Please read the warranty statement and check your battery before requesting repair. During the warranty period any defective test tool can be returned to your Amprobe® Test Tools distributor for an exchange for the same or like product. Please check the "Where to Buy" section on [www.amprobe.com](http://www.amprobe.com) for a list of distributors near you. Additionally, in the United States and Canada In-Warranty repair and replacement units can also be sent to a Amprobe® Test Tools Service Center (see address below).

### **Non-Warranty Repairs and Replacement – US and Canada**

Non-warranty repairs in the United States and Canada should be sent to a Amprobe® Test Tools Service Center. Call Amprobe® Test Tools or inquire at your point of purchase for current repair and replacement rates.

#### **In USA**

Amprobe Test Tools  
Everett, WA 98203  
Tel: 877-AMPROBE (267-7623)

#### **In Canada**

Amprobe Test Tools  
Mississauga, ON L4Z 1X9  
Tel: 905-890-7600

### **Non-Warranty Repairs and Replacement – Europe**

European non-warranty units can be replaced by your Amprobe® Test Tools distributor for a nominal charge. Please check the "Where to Buy" section on [www.amprobe.eu](http://www.amprobe.eu) for a list of distributors near you.

#### **European Correspondence Address\***

Amprobe® Test Tools Europe

Beha-Amprobe GmbH  
In den Engematten 14  
79286 Glotttetal, Germany  
Tel.: +49 (0) 7684 8009 - 0

[www.amprobe.eu](http://www.amprobe.eu)

Robin-Amprobe® Test Tools UK

52 Hurricane Way  
Norwich, Norfolk, NR6 6JB  
United Kingdom

Tel.: +44 (0) 1603 25 6662 Fax.: +44 (0) 1603 25 6664

[www.robin-amprobe.co.uk](http://www.robin-amprobe.co.uk)

\*(Correspondence only – no repair or replacement available from this address. European customers please contact your distributor.)

## KMP7036 Insulation-Continuity Tester

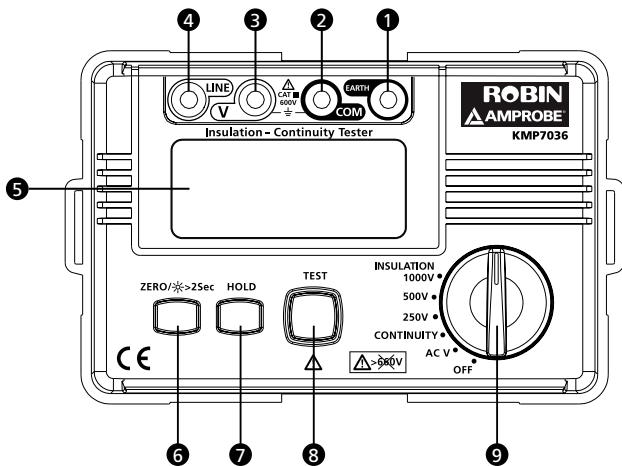

- 1 EARTH: Terminal for insulation resistance measurement
- 2 COM: Return terminal for Voltage and Continuity measurement
- 3 V: Input terminal for Voltage measurement
- 4 LINE: Terminal for insulation resistance measurement
- 5 LCD Display
- 6 Test lead resistance zero function / Display backlight button
- 7 Data Hold button
- 8 TEST Button
- 9 Rotary switch

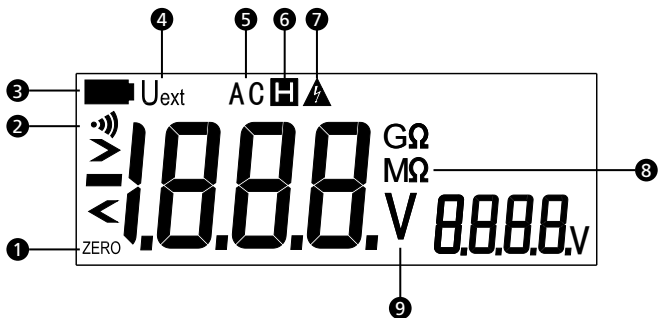









- 1** Test Lead Resistance Zero mode
- 2** Continuity Buzzer
- 3** Low Battery Indicator
- 4** External Voltage Warning
- 5** AC Voltage
- 6** Data Hold
- 7** Hazardous Voltage presents at terminals
- 8** Measurement Unit for Resistance
- 9** Measurement Unit for Voltage

# KMP7036 Insulation-Continuity Tester

## CONTENTS

<b>SYMBOLS</b> .....	2
<b>SAFETY INFORMATION</b> .....	2
<b>UNPACKING AND INSPECTION</b> .....	3
<b>FEATURES</b> .....	4
<b>MAKING MEASUREMENT</b> .....	4
Rotary Switch Positions .....	5
Function Buttons .....	5
Measuring AC Voltage .....	6
Measuring Continuity .....	7
Measuring Insulation Resistance .....	8
<b>SPECIFICATIONS</b> .....	10
<b>MAINTENANCE AND REPAIR</b> .....	12
<b>REPLACING THE BATTERY</b> .....	12

## SYMBOLS

	Caution ! Risk of electric shock.
	Caution ! Refer to the explanation in this Manual.
	The equipment is protected by double insulation or reinforced insulation.
	Do not use in distribution systems with voltages higher than 660 V.
	Earth (Ground).
	Battery
	Complies with European Directives.
	Do not dispose of this product as unsorted municipal waste. Contact a qualified recycler.

## SAFETY INFORMATION

---

This Tester complies with:

EN 61010-1 3rd Edition, Category III 600 Volts, Pollution degree 2, IP40 as per EN 60529

EN 61010-2-31 for test leads

EMC EN 61326-1

EN 61557-1/-2/-4/10

**Measurement Category III (CAT III)** is for measurements performed in the building installation. Examples are measurements on distribution boards, circuit-breakers, wiring, including cables, bus-bars, junction boxes, switches, socket-outlets in the fixed installation, and equipment for industrial use and some other equipment, for example, stationary motors with permanent connection to the fixed installation.

### CENELEC Directives

The instruments conform to CENELEC Low-voltage directive 2006/95/EC and Electromagnetic compatibility directive 2004/108/EC



## **Warning: Read Before Using**

- *To avoid possible electrical shock or personal injury, follow these instructions and use the Tester only as specified in this manual.*
- *Do not use the Tester or test leads if they appear damaged, or if the Tester is not operating properly. If in doubt, have the Tester serviced.*
- *Always use the proper function and range for measurements.*
- *Always connect the test leads to the correct terminals when testing.*
- *Before rotating the function range selection switch, disconnect test probe from circuit under test.*
- *Verify the Tester's operation by measuring on a known voltage source for voltage measurement.*
- *Verify the Tester's operation by measuring on a known resistance source for resistance measurement.*
- *Do not apply more than the rated voltage, as marked on the Tester, between the test probe or between any test probe and earth ground.*
- *Do not use in distribution systems with voltages higher than 660V AC.*
- *Use the Tester with caution for voltages above 30 Vac rms, 42 Vac peak, or 60 Vdc. These voltages pose electrical shock hazards.*
- *Disconnect circuit power and discharge all high-voltage capacitors before testing insulation resistance and continuity.*
- *Do not use the Tester around explosive gas or vapor.*
- *When using the test probes, keep your fingers behind the finger guards.*
- *Do not touch the circuit under measurement.*
- *Before and after testing, verify there is no presence of hazardous voltage at the terminals•*
- *Remove test leads from the Tester before opening the Tester's case or battery door.*

## **UNPACKING AND INSPECTION**

---

Your shipping carton should include:

- 1 KMP7036 Insulation-Continuity Tester
- 1 Pair of Test Leads (Red and Black)
- 1 Pair of Test Probes (Red and Black)
- 1 Pair of Alligator Clips (Red and Black)
- 6 1.5V alkaline AA battery
- 1 Users manual
- 1 Strap
- 1 Carrying case

If any of the items are damaged or missing, return the complete package to the place of purchase for an exchange.

## FEATURES

---

The quality of insulation is critical to assure proper, uninterrupted and safe functioning of the electrical circuits. Robin-Amprobe Insulation-Continuity Tester is designed to diagnose and prevent the breakdown of the insulation in various parts of the electrical system such as wires, transformers and motors. The KMP7036 features three testing voltages covering wide range of commercial and residential applications.

- Tests insulation of wires, cables, transformers and electrical motors
- Selectable insulation test voltages 250V, 500V and 1000V
- Test button hold to perform the Dielectric Absorption Ratio Test
- Continuity test @ 200mA short-circuit
- Designed to allow testing to BS7671 IEE 17th Edition regulations
- Built in voltmeter and red light warning for live circuit indication
- Large backlit display
- Automatic discharge of test object after completion of measurement
- Data Hold
- Test lead resistance zero facility
- Low Battery Indication
- Safety CAT III 600V

## MAKING MEASUREMENT

---







- Use the proper function and range for measurements.
- To avoid possible electrical shock, personal injury or damages to the Tester, disconnect circuit power and discharge all high-voltage capacitors before testing resistance, diode capacitance and temperature.
- Always connect the test leads to the correct terminals when testing.
- Before rotating the function range selection switch, disconnect test probe from circuit under test.

- Verify the Tester's operation by measuring on a known source
- Do not use in distribution systems with voltages higher than 660V AC.
- Use the Tester with caution for voltages above 30 Vac rms, 42 Vac peak, or 60 Vdc. These voltages pose electrical shock hazards.

## Rotary Switch Positions

Switch Position	Measurement Function
OFF	Turn off the Tester.
CONTINUITY	Continuity resistance measurement.
INSULATION 250V / 500V / 1000V	Insulation resistance measurement at 250V or 500V or 1000V. Press TEST button to begin Insulation test. Test button will hold for continuous measurement, press again to stop the measurement.

## Function Buttons

Button	Measurement Function
TEST	Press to start insulation resistance test. TEST button will hold for Dielectric Absorption Ratio Test (DAR) purpose. DAR value can be calculated by $R_{iso}(1min)/R_{iso}(30s)$ . Press TEST button again to stop the measurement.
HOLD	Display freezes present reading. Display shows  symbol when Data Hold is enabled. Press HOLD button again to exit Data Hold function (  disappears on display).
ZERO /  > 2 Sec	ZERO: Test lead resistance zero for continuity measurement.  > 2 Sec: Press > 2 sec to turn the display backlight on or off.

## Measuring AC Voltage



- To avoid possible electrical shock, personal injury or damages to the Tester, connect the test leads to the correct terminals.
- Connect the common (COM) test lead to the circuit before connecting the live lead. After measurement, remove live lead before removing the common (COM) test lead from the circuit

- Verify the Tester's operation by measuring on a known source
- Do not use in distribution systems with voltages higher than 660V AC.
- Use the Tester with caution for voltages above 30 Vac rms or 42 Vac peak. These voltages pose electrical shock hazards.
- Before rotating the function range selection switch, disconnect test probe from circuit under test.

### To Measure AC Voltage:

1. Turn the rotary switch to AC V position
2. Use the V and COM terminals for this test with test leads.
3. Display shows the measured AC voltage.

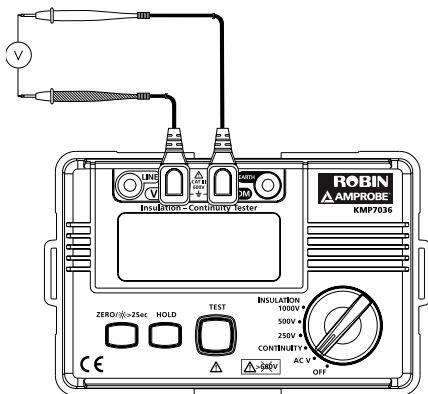

### Measuring Continuity



- Disconnect circuit power and de-energize the circuit before test.
- Do not measure continuity at live voltage circuit.
- Do not attempt to make measurement when the battery compartment is open or accessible.

- Warning buzzer will sound when the Tester detects a voltage  $>10\text{Vac}$  or dc.  
Display shows "Uext" and 

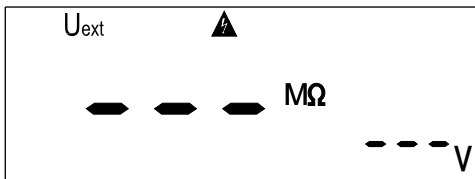

### To measure continuity:

1. Turn the rotary switch to Continuity position.
2. Use V and COM terminals for this test with test leads.
3. Before making a continuity measurement, use ZERO function to zero the test lead resistance.

#### Test lead resistance zeroing:

**Step 1:** Connect the test leads to V and COM terminal and short-circuit the test leads/probes.

**Step 2:** Press TEST button (continuous measurement). Display shows the measured resistance.

**Step 3:** Press ZERO button. Test lead resistance zeroing completes when display shows  $0.00\Omega$ , ZERO annunciator appears on display.

#### Note:

- The ZERO function can subtract up to  $10\Omega$  of lead resistance. Buzzer audio sound for lead resistance
- Test lead resistance zeroing is advised to be repeated next time you switch to continuity function. Last leads resistance is not saved if the Tester is switched off or is switched to another measurement function.
- Unsuccessful test lead resistance zeroing (resistance  $>10\Omega$ ):
  - Buzzer warning sound
  - Display retains measured test lead resistance, ZERO annunciator is not shown on display.

4. Press TEST button (continuous measurement)  
The primary display shows the continuity resistance.  
The secondary (smaller digits on the right side) display shows the actual output DC voltage.  
buzzer threshold:  $2\Omega$  (when  symbol on screen)

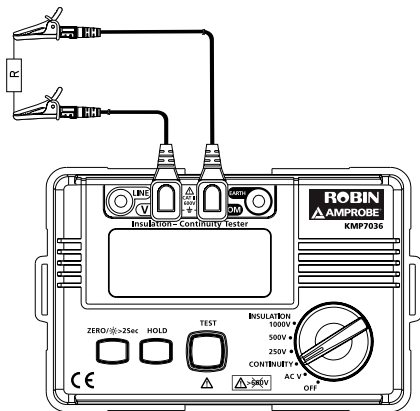

## Measuring Insulation Resistance



- Disconnect circuit power and de-energize the circuit before test.
- Do not measure insulation at live voltage circuit.
- When measuring insulation resistance, make sure the two test leads are separated and are not twisted together.
- Do not short circuit two test leads when output DC voltage presents at the output terminals.
- Do not attempt to make measurement when the battery compartment is open or accessible.
- Do not touch the circuit under measurement.  symbol on display indicates hazardous output voltage at the terminals.

- When the measurement is completed, do not touch the circuit as the circuit may store energy, which may cause electric shock. Allow time for circuit to discharge or discharge the circuit (capacitors) after the measurement.

#### To measure insulation resistance:

1. Turn the rotary switch to 250V or 500V or 1000V position as required.
2. Use LINE and EARTH terminals for the test with test probes or alligator clips.
3. Press TEST button to begin insulation resistance test. TEST button will hold for continuous measurement. Red warning light on TEST button indicates the presence of hazardous voltages at the terminals.

The primary display shows the insulation resistance.

The secondary (smaller digits on the right side) display shows the actual output DC voltage.

Buzzer threshold: 4M $\Omega$

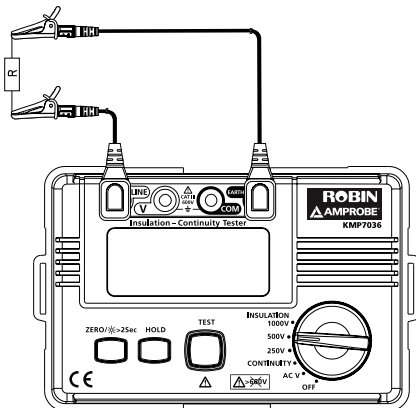

## SPECIFICATIONS

---

**Ambient temperature:** 23°C ±5°C (73.4°F ±9°F); Relative temperature: ≤75%

**Accuracy:** ±(% of reading + LSD)

**Maximum display:** Digital 1999 counts

**Over-range indication:** Voltage "OL V", Continuity ">200Ω", Insulation ">2.2GΩ".

**Range:** Automatic

**Altitude:** Operating ≤ 2000m

**Operating temperature:** 0°C ~ +35°C (32°F ~ 95°F), Relative humidity ≤70%

**Storage temperature:** -20°C ~ +60°C (14°F ~ 122°F), Relative humidity ≤80%

**Power Supply:** Alkaline Battery 1.5V (AA Battery or equivalent) × 6pcs

**Low Battery warning indication:**  (when batteries are below DC 6.8V).

The number of possible tests with a fresh set of batteries is >1100.

**Dimensions (L x W x H):** 160 x 101 x 71mm (6.30 x 3.98 x 2.79in)

**Weight:** Approx. 500g (1.1 lb) with batteries installed

### AC Voltage Measurement

Range	Resolution	Accuracy
30V – 750V	1V	± (2% Rdg + 3 LSD) @ 50/60Hz

### Continuity Measurement

Range (auto ranging)	Resolution	Accuracy
0.00Ω – 1.99Ω	0.01Ω	± (2% Rdg + 3 LSD)
2.0Ω – 19.9Ω	0.1Ω	
20Ω – 200Ω	1Ω	

**External Voltage detection:** 10Vac or 10Vdc

**Short-Circuit  $I_N$**  ≥ 200mA

**Output Voltage  $U_o$**  = 5Vdc (Nominal)

**Buzzer threshold:** 2Ω



## Insulation Resistance Measurement

DC Test Voltage	Resolution	Test Current	Accuracy
250V	1V	$\geq 1\text{mA} @ 0.25\text{M}\Omega$	0 to +10%
500V		$\geq 1\text{mA} @ 0.5\text{M}\Omega$	
1000V		$\geq 1\text{mA} @ 1\text{M}\Omega$	

Measuring Range (auto ranging)	Resolution	Accuracy
0.00M $\Omega$ – 9.99M $\Omega$	0.01M $\Omega$	$\pm (3\% \text{ Rdg} + 5 \text{ LSD})$
10.0M $\Omega$ – 99.9M $\Omega$	0.1M $\Omega$	$\pm (3\% \text{ Rdg} + 5 \text{ LSD})$
100M $\Omega$ – 1999M $\Omega$	1M $\Omega$	$\pm (5\% \text{ Rdg} + 5 \text{ LSD})$

Buzzer threshold: 4M $\Omega$

Automatic Discharge of tested object: Yes

## EN 61557 MEASUREMENT RANGE

Function	Display Range	EN 61557 Measurement Range Operating Error	Nominal Values
Volts EN 61557-1	30Vac – 750Vac, 50/60Hz	30Vac – 600Vac, 50/60Hz $\pm(2\% + 3 \text{ LSD})$	$U_N = 230\text{Vac}$ $f = 50\text{Hz}$
Insulation EN 61557-2	0.00M $\Omega$ – 2000M $\Omega$	0.25M $\Omega$ - 2000M $\Omega$ $\pm(5\% + 5 \text{ LSD})$	$U_N = 250 / 500$ / 1000Vdc $I_N = 1.0\text{m}$
Continuity EN 61557-4	0.00 $\Omega$ – 200 $\Omega$	0.2 $\Omega$ - 199 $\Omega$ $\pm(2\% + 5 \text{ LSD})$	$U_O = 5\text{Vdc}$ (typical) $I_N \geq 200\text{mA}$

## MAINTENANCE AND REPAIR

---

If the Tester fails to operate, check battery, test leads, etc., and replace as necessary. Double check the followings:

1. Check the battery. Replace the battery immediately when the symbol "" appears on the LCD.
2. Review the operating instructions for possible mistakes in operating procedure.

Except for the replacement of the battery, repair of the Tester should be performed only by a Factory Authorized Service Center or by other qualified instrument service personnel.

The front panel and case can be cleaned with a mild solution of detergent and water. Apply sparingly with a soft cloth and allow to dry completely before using. Do not use aromatic hydrocarbons, Gasoline or chlorinated solvents for cleaning.

## BATTERY AND FUSE REPLACEMENT

---



### **WARNING**

*To avoid shock, injury, or damage to the Tester, disconnect test leads before opening case.*

Replacing BATTERY follow below steps:

1. Turn the rotary switch to OFF position and disconnect the test lead probe from measuring circuit.
2. Remove the screws from the battery cover and open the battery cover
3. Remove the batteries and replace with six 1.5V batteries (AA or equivalent). Pay attention to the polarity signs.
4. Put the battery cover back and re-fasten the screw.

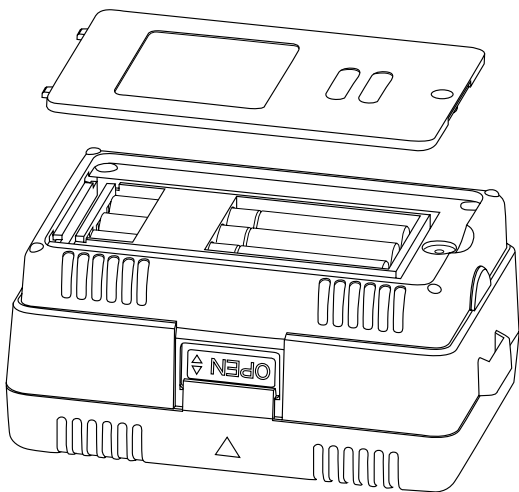

Visit [www.robin-amprobe.co.uk](http://www.robin-amprobe.co.uk) for

- **Catalog**
- **Application notes**
- **Product specifications**
- **User manuals**



Please Recycle