

Dragonfish Pro

User Manual

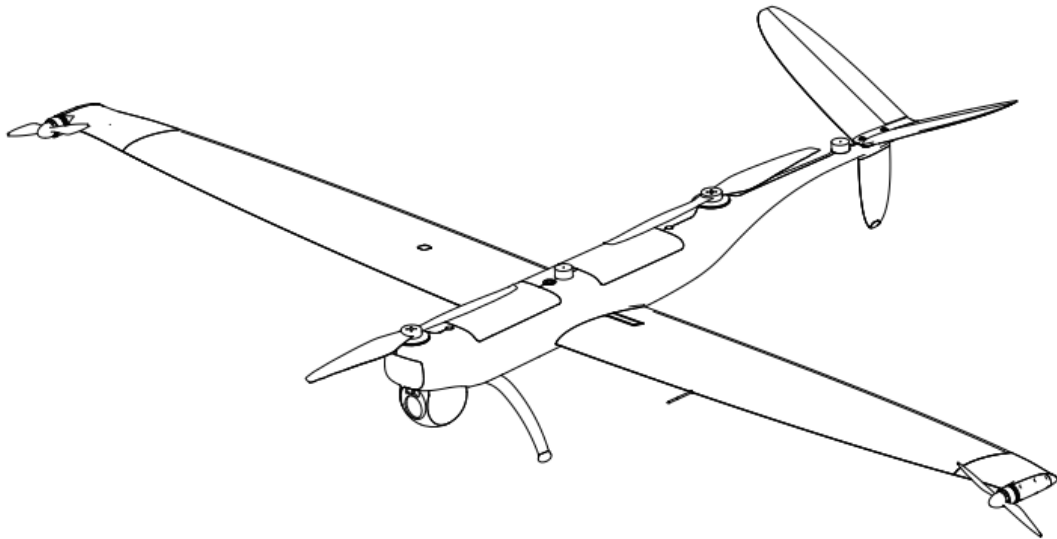

Legend keys

Please pay attention to the legend keys in this Manual.



Warning: Remind the possible danger.



Important: Matters needing attention in flight operation.



Remark: supplementary information.



Reminding: Reminding information to get the best operating experience of Aircraft.



References: Page numbers to help you find chapters that contain relevant information.

Product User Terms

Thank you for your interest in the industry aircraft products provided by Autel Robotics Co., Ltd (hereinafter referred to as "Autel Robotics"). Please read the following terms carefully and acknowledge that you have understood and agreed the following terms, conditions and safe operation guide.

1. Disclaimer

In order to ensure safety and successfully operate your Dragonfish Pro aircraft, please abide by the operating instructions and procedures of this Manual.

Children are not allowed to use this aircraft. The aircraft shall be kept out of the reach of children when it is not used. If user fails to abide by the safe operating instructions, Autel Robotics will assume no responsibility for any product damage or loss--(direct or indirect, legal, special or economic loss (including but not limited to profit loss)) during use, and will not provide warranty service. Never modify your product by using any incompatible component or any method that is not required in Autel Robotics official description.

This Manual will show you the safe operating procedures of aircraft. Please acknowledge that your operation will not endanger your and other personal and property safety. This Manual will update without a fixed schedule. In order to ensure your use of the latest version, please visit: www.autelrobotics.com/download/99

2. Data Storage and Use

The backup service function of this product is disabled by default, so user and flight information will not be uploaded or propagated through mobile device. When Autel Voyager is connected with an aircraft, the flight log including the flight remote sensing data will be uploaded and saved in the Autel Robotics data server. All remote sensing data and flight logs can be uploaded automatically only when the flight log backup option is enabled. Without the explicit authorization of user through

Autel Voyager, Autel Robotics customer service team has no right to access to the flight log data. With the authorization, it is only allowed to access to the flight logs within the selected time.

Various still images, motion images and data from the aircraft sensor will be stored in the internal drive of aircraft. If your UAV needs repair, then the information stored in the internal memory unit can be used for problem diagnosis. This information will not be retained, unless for processing service or repair. Never delete or change any data stored in the internal memory unit in any form, otherwise Autel Robotics will not provide warranty.

The data collected by Autel Robotics are for providing support and service and improving product performance. We will seriously treat your privacy like ourselves. We can agree to disclose any uploaded data only when the law requires.

For privacy right policy, please visit www.autelrobotics.com/page/privacy

3. Safe operation guide

Battery safety

The Dragonfish Pro UAV is powered by lithium-ion polymer batteries. Improper use of lithium-polymer/lithium-ion batteries can be dangerous. Please ensure that all the following battery use, charging and storage guidelines are strictly followed.

Warning

- Only use the battery and charger provided by Autel Robotics. Neither modify battery and its charger and do not use or replace them with the third party equipment.
 - The electrolyte in the battery is very corrosive. If the electrolyte accidentally touches your eye or skin, immediately rinse with clear water and quickly see a doctor.
-

Battery use

Be sure to turn off the aircraft's power before installing or removing battery. Other precautions are as follows:

- Only use the battery and charger sold or authorized by Autel Robotics for Dragonfish Pro. The use of any unapproved battery or charger may cause fire, explosion, leakage or other dangers. Autel Robotics will assume no responsibility for any consequence of using the battery or charger of third party.
- Be sure to fully charge the battery before each flight.
- If the aircraft enters the low battery alarm mode, it is necessary to land the aircraft, stop flying, replace or charge the battery as soon as possible.
- Never decompose, scratch, extrude, bend, pierce, cut, distort or damage the battery in other forms. Otherwise fire, explosion, leakage or other dangers may be caused.
- If the battery is bulging, smoking, leaking or is otherwise damaged, immediately stop use or charging, and soak the battery in a vessel containing saline water.
- Please use the battery at the suitable temperature (-20°C-40°C). The use at high or low temperature will affect the battery life. Too high temperature may cause fire or spontaneous

combustion; too low temperature may cause permanent damage of battery.

- When the battery is at a temperature lower than 10°C, the battery needs to be preheated before taking off.
- Do not use the battery in a strong electrostatic or electromagnetic environment.
- Do not expose the battery to fire, explosions or other dangers.
- Never place the battery in a microwave oven or pressure cooker.
- If the aircraft falls into water, the battery must be taken out immediately after it is recovered. Place the battery in an open space and keep a safe distance till that the battery is fully dried. Stop using the battery, and contact the customer service center for replacement.

Battery charging

Fully charging the battery takes a maximum of 120 minutes; charging time is related to the remaining battery level. Other precautions are as follows:

- Never use a damaged battery charger.
- Disconnect the charger from the aircraft battery and power supply when not in use.
- Only charge after the battery is cooled to room temperature. If the battery is connected with the charger immediately after flight, the over temperature protection function may be activated to stop battery charging till that the battery is fully cool.

Storage and transportation of battery

The battery must be protected from close contact with water or heat source when in storage. The battery shall be stored in a dry and well-ventilated place at room temperature (ideal temperature of 22°C-28°C (72°F- 82°F)).

Other precautions are as follows:

- The battery must be kept out of the reach of children and pets.
- Never place the battery in direct sunlight or near sharp objects, water, metal or reactive chemicals.
- Storing the battery in extreme temperatures will shorten the battery service life. If the battery is not used for 1 day above, it must be stored between -10°C(14°F) and 30°C(86°F). Otherwise, the battery damage or failure may be caused.
- If the battery is not used for an extended period, the battery service life will be shortened. Never transport a damaged battery. If the battery needs to be transported by rail or air, it must be discharged to 20-30%.

Battery disposal

- The battery must be thoroughly discharged before it is discarded in a designated battery recycling bin.
- The battery contains dangerous chemicals, so it is unlawful to discard in ordinary trash. For more details, please abide by the local recycling and disposal laws and regulations.

Safe UAV flight

Flight environment

- Please abide by the local laws and regulations while flying UAV. Fly only in the designated aircraft movement areas, and use Autel Voyager App to set the required distance and height limits.
- Do not fly in dangerous situations or severe weather conditions such as tornadoes, rain, hail

and snow.

- Fly in an open and safe area. Stay away from obstacles that may interfere with GPS signals, such as buildings and trees.
- Be extremely careful when flying above 6000 m (18,000 ft), Performance of the battery and power system of the aircraft may be affected at high altitudes

Pre-flight

Before the UAV flies, it is always necessary to pay attention to the following matters:

- The remote controller, flight battery should be fully charged.
- The propellers must be correctly installed without damage.
- All parts of the aircraft must be completely installed.
- The motor, gimbal and camera must work normally after the aircraft is powered on.
- All warnings and errors displayed on Autel Voyager must be handled.
- Only use accessories provided with this aircraft or sold or authorized by Autel Robotics. Using unapproved accessories can bring serious safety risks and will invalidate the product warranty.

In-flight

- The aircraft must keep away from people, vehicle and other moving objects during takeoff and landing.
- Do not cancel the auto return process in the event of a low battery alarm. Otherwise the aircraft may not return to the return point due to insufficient power.
- When Autel Voyager displays an alarm, immediately carry out the operation according to relevant specification.
- Do not operate the aircraft if you have any physical condition that may affect safe operation, including but not limited to dizziness, fatigue, intoxication, or high blood pressure.

Warning

- If any part of the aircraft or the remote controller fails to work normally or is visibly damaged, please do not fly any longer and contact the Autel Robotics customer service team: www.autelrobotics.com/page/contact

Storage and maintenance

Carefully check each part of the aircraft after any collision or extrusion. Store the aircraft and its accessories out of the reach of children and pets.

- Store the aircraft and its accessories in a cool and dry place.
- Keep the aircraft away from water and heat sources.
- The aircraft's recommended storage temperature is between 22°C and 28°C (72°F to 82°F).

The Autel Robotics customer service team is always ready to provide assistance via chat, mobile phone or email (after-sale@autelrobotics.com).

Contents

| | |
|--|-----------|
| Chapter 1 About the Manual | 8 |
| 1.1 Instructions for the first flight | 8 |
| 1.1.1 Documents of start guide | 8 |
| Chapter 2 Be familiar with your Dragonfish Pro..... | 9 |
| 2.1 Product overview | 10 |
| 2.1.1 Aircraft | 10 |
| 2.1.2 Gimbal camera | 11 |
| 2.1.3 Base station | 11 |
| 2.1.4 Aircraft battery | 13 |
| 2.1.5 Intelligent flight control system | 16 |
| 2.1.6 Intelligent flight features | 17 |
| 2.2 Ground station..... | 18 |
| 2.2.1 Portable ground station | 18 |
| 2.2.2 Autel Voyager App | 20 |
| Chapter 3 Flight preparation..... | 23 |
| 3.1 Battery preparation..... | 23 |
| 3.1.1 Aircraft battery charging | 23 |
| 3.1.2 Ground station battery charging..... | 23 |
| 3.1.3 Base station charging | 24 |
| 3.2 Ground station preparation..... | 24 |
| 3.2.1 Extend ground station | 24 |
| 3.2.2 Turn on/off ground station..... | 25 |
| 3.2.3 Frequency pairing of the aircraft and the ground station | 25 |
| 3.2.4 Ground station calibration..... | 26 |
| 3.3 Base station preparation..... | 27 |
| 3.3.1 Base station construction..... | 27 |
| 3.4 Aircraft preparation | 28 |
| 3.4.1 Assemble aircraft..... | 28 |
| 3.4.2 Activate aircraft..... | 30 |
| 3.5 Flight..... | 31 |
| 3.5.1 Manual takeoff..... | 31 |
| 3.5.2 Automatic takeoff..... | 33 |
| Chapter 4 Flight Operation..... | 35 |
| 4.1 Precautions..... | 35 |
| 4.2 Ground station and flight operation | 36 |
| 4.2.1 Motor start and aircraft take off | 37 |
| 4.2.2 Manipulator control (Mode 2)..... | 38 |
| 4.2.3 Landing and motor off..... | 38 |

| | |
|---|---------------|
| Chapter 5 Maintenance and service | 40 |
| 5.1 Firmware update | 40 |
| 5.2 Solutions to common faults..... | 40 |
| 5.3 Storage and maintenance..... | 41 |
| 5.4 Warranty | 41 |
| 5.5 Customer service..... | 42 |
| 5.5.1 Technical support | 42 |
| 5.5.2 Maintenance service..... | 43 |
| Chapter 6 Annex..... | 44 |
| 6.1 Restricted area and indexes of laws and regulations | 44 |
| 6.1.1 Diagram of restricted area | 44 |
| 6.1.2 Indexes of laws and regulations for Chinese UAVs | 45 |
| 6.2 Specifications | 46 |

Chapter 1

About the Manual

Thank you for purchasing your Dragonfish Pro UAV from Autel Robotics. With this Manual, you can understand the features of Dragonfish Pro products and learn to operate this aircraft and remote controller optimally. Before first use of Dragonfish Pro products, please read this Manual and attached documents. Use this Manual for reference if needed during flight.

1.1 Instructions for the first flight

1.1.1 Documents of start guide

The following documents provide a start guide for you to use the Dragonfish Pro UAV for the first time.

1. **Quick Start Guide:** Basic knowledge for operating the Dragonfish Pro product, including list of articles. If any of these are missing, please contact the Autel Robotics customer support or your local retailer.
2. **User Manual:** to teach you the operating methods of Dragonfish Pro products.
3. **Quick guide to base station:** basic knowledge of using base station
4. **Disclaimer and Safe Operation Guide:** instructions to safely operate Dragonfish Pro products
5. **Quick Start Guide for Batteries:** basic knowledge of smart batteries.
6. **Charger Quick Guide:** basic knowledge of using charger.

Download website: www.autelrobotics.com/download/99

Warning

- Please check the aircraft and other accessories listed on the **Product List** in packing box. Do not modify this aircraft by using any incompatible component or any method that is not required in official description.
-

Chapter 2

Be familiar with your Dragonfish Pro

The Dragonfish Pro integrates intelligent flight control technology, gimbal technology and imaging technology from Autel Robotics. It adopts a unique tilt-rotor design, easy disassembly and efficient aerodynamic design. It combines the flexibility of multi-rotor takeoff and landing with the fixed-wing flight endurance. It features one-key automatic takeoff and landing, and flight functions such as intelligent tracking, pointed flight, terrain following and fast tasks. The body's protective structure is rated IP43 (referring to the IEC60529 Standard). The loaded flight time of the Dragonfish Pro is up to 158 minutes. The high-definition dual-frequency image transmission distance is as long as 30km, and the whole system can self-check in 5 seconds, and assembled rapidly in 3 minutes.

The high-performance camera has a 240x hybrid optical variable and a 2000-meter infrared detection capability. Combined with Autel Robotics' advanced software and hardware, it redefines productivity tools and empowers industry applications.

Dragonfish Pro is compatible with dual-optical, triple-optical, multi-spectral, and third-party mounting, and supports PSDK to meet use needs of different customers. Dragonfish Pro integrates high-performance dual-engine RTK and conventional GNSS positioning modules, and with the Dragonfish base station, it can achieve high-precision and accurate positioning. The Dragonfish Pro battery, IMU, barometer, compass, and positioning system are all backed up, with multiple redundancy, safety and reliability systems.

2.1 Product overview

2.1.1 Aircraft

The aircraft is mainly composed of four main parts: the fuselage, the left wing, the right wing, and the tail wing. Internally, it contains an automatic driving system, a power system, a data transmission system, a positioning system, an intelligent power supply system, a load system, etc.

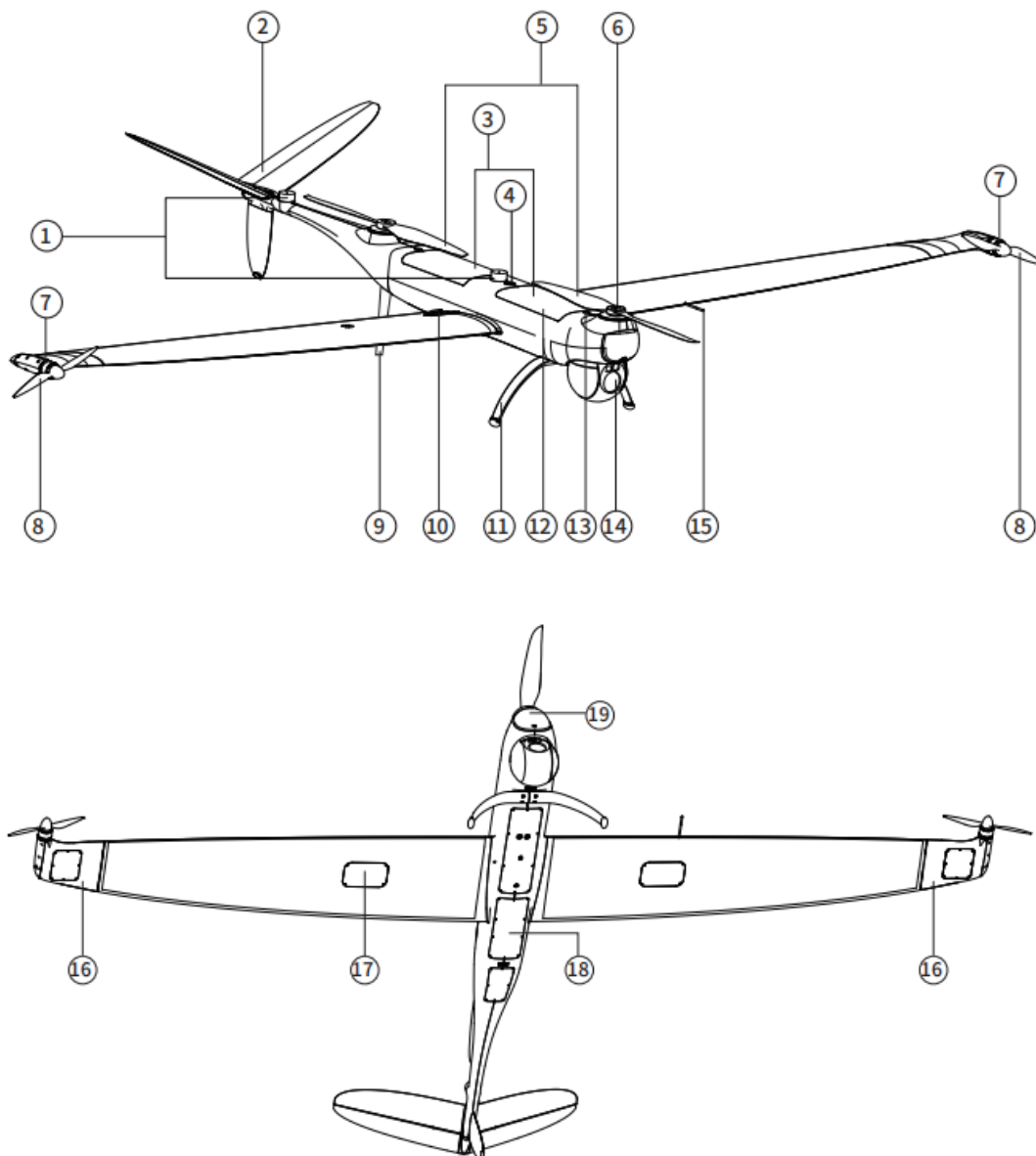

- | | |
|----------------------------|----------------------------|
| ① RTK antenna | ⑪ buttonFront landing gear |
| ② Tail | ⑫ Battery cover |
| ③ Smart battery | ⑬ Battery release |
| ④ Power button / indicator | ⑭ Airspeed sensor |
| ⑤ Propeller blades | ⑮ Gimbal camera |
| ⑥ Body motor | ⑯ Tilting wingtip |
| ⑦ Wing motor | ⑰ GPS |
| ⑧ Wingtip propellers | ⑱ Ultrasonic sensor |

- ⑨ Rear landing gear
- ⑩ Wing lock

- ⑲ Millimeter-wave Radar

2.1.2 Gimbal camera

Dragonfish Pro is equipped with a high-precision 3-axis stabilization gimbal to ensure stability and clarity of high-altitude and high-speed aerial pictures. It is compatible with a variety of mounts, and supports multiple loads of dual-lens cameras, triple-lens cameras, multi-spectral cameras, third-party cameras, etc., to meet the application needs of different industries. For details, please consult sales staff of Autel Robotics.

- **Gimbal working mode**

- **Posture locking mode:** The rolling direction is kept at 0°. The gimbal heads in a fixed position set by the user, and does not yaw with the aircraft heading. The user can adjust the gimbal pitch angle.
- **Heading following mode:** The rolling direction is kept at 0°. The gimbal yaws along with the aircraft heading. The user can remotely control the gimbal pitch angle.

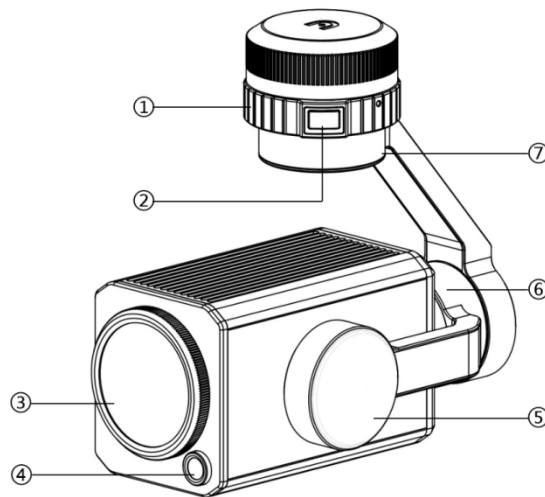

- | | |
|---------------------|-----------------------|
| ① Lock ring | ⑤ Pitching axis motor |
| ② Unlocking key | ⑥ Rolling axis motor |
| ③ Zoom camera | ⑦ Yawing axis motor |
| ④ Wide angle camera | |

2.1.3 Base station

The Dragonfish base station is a high-precision satellite signal receiver that supports 11-frequency satellite signal reception. It is compatible with GPS, Beidou, Galileo and Glonass navigation systems. It has a built-in data transmission system that is convenient for users to use in different application environments. The Dragonfish base station can be used as an RTK base station to improve the positioning accuracy from meter level to centimeter level. It also provides good anti-magnetic interference capabilities to ensure reliable flight in environments with intensive magnetic interference such as high-voltage lines and metal buildings.

- **Base station main body**

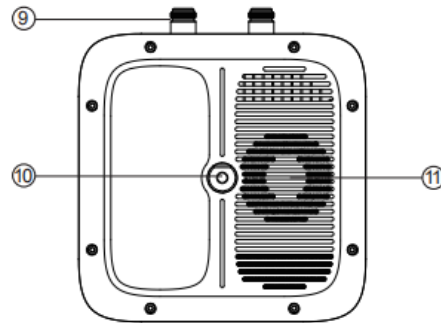
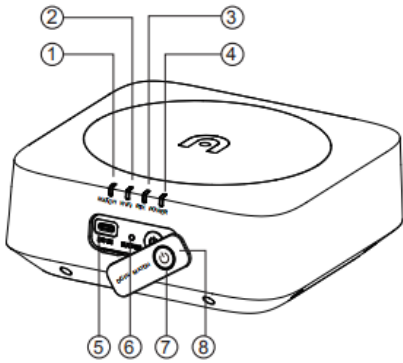

- ① Frequency pairing indicator
- ② Wi-Fi indicator
- ③ RTK indicator
- ④ Power indicator
- ⑤ USB-C charge interface
- ⑥ Frequency pairing button

- ⑦ Power button
- ⑧ Port cover
- ⑨ Antenna N-shaped connector
- ⑩ Turntable mounting hole
- ⑪ Cooling hole

- **Tripod**

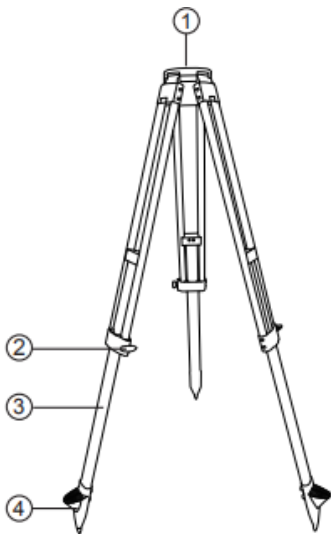

- ① Fixing screw
- ② knob
- ③ Telescopic rod
- ④ Foot pin

- **Use method**

- **Turn on**

The base station has 2 working modes: normal mode and disabled RTK mode, which can be used in different operating scenarios. Follow the instructions below to turn on the base station and enter the different working modes.

1. With the base station turned off, press and hold the power supply button for 1s to enter into the normal mode.
2. With the base station turned off, press and hold the power supply button for 3s to enter into the disabled RTK mode. You will hear 3 beeps when entering into the mode, and the RTK indicator will be red.

➤ **Turn off**

Press and hold the power supply button for 1s to turn off.



➤ **connect the ground station or aircraft**

Using the normal mode as example, the specific operations are as follows:

A. Frequency pairing of the base station with the aircraft

1. Click the base station frequency pairing button. The frequency pairing indicator will flash;
2. Press the frequency pairing button in the rear battery compartment of the aircraft to enable the aircraft to enter into the frequency pairing state. The aircraft fuselage frequency pairing indicator will flash quickly during the pairing process.
3. After frequency pairing succeeds, the frequency pairing indicator on the base station will flash in red at frequency of 0.1s/2.0s

B. Connect ground station to base station

1. Turn on the base station power supply;
2. Turn on the remote controller and run the Autel Voyager App, select "Settings -> Base Station." After entering, when you see the base station WiFi hot spot, enter the password: 12345678, wait for seconds till the remote controller: is successfully connected with the base station;
3. Exit the setting interface, enter the task flight interface, click the gear icon in the upper right corner, enter the setting menu, click "Remote controller" to open the option "Base station use connection".

| Description of image transmission state indicator | |
|--|--|
| Green light 1.5s/1.5s slow blinking flash | Image transmission is not connected |
| Green light 0.1s/0.1s rapid blinking flash | In image transmission frequency pairing |
| Green light 0.1s/2.0s blinking flash | Image transmission is normally connected |
| Green light 3s/0.2s blinking flash | In upgrade data downloading |
| Normally on green | In firmware update |

2.1.4 Aircraft battery



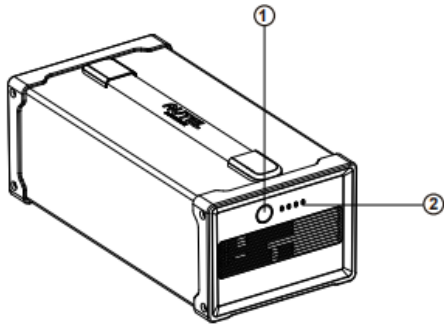





The rechargeable lithium polymer battery used in the Dragonfish Pro is high energy and high capacity, and should be charged with the provided special charger.















- ① Power button
- ② Battery level indicator

● **Check battery level**



















When the battery is turned off, press the **power button** for 1 second and then release it quickly to check the battery level. LED will indicate the current battery level, as shown below.

| Battery level indicator status (non-charging status) | | | |
|---|---|---|--|
| 0%~12% | 13%~25% | 26%~37% | <ul style="list-style-type: none"> ⓪ - Green is flashing ■ - Green is normally on □ - Off |
|  |  |  | |
| 38%~50% | 51%~62% | 63%~75% | |
|  |  |  | |
| 76%~87% | 88%~100% | | |
|  |  | | |

● **LED warning description**

| LED 1 | LED 2 | LED 3 | LED 4 | Warning description |
|---|---|---|---|---|
|  |  |  |  | The charging temperature is too high or too low. |
|  |  |  |  | The charging current is high enough to cause short circuit. |
|  |  |  |  | There is overcurrent, overload or short circuit problem in the case of discharging. |
| ⓪ - Indicator is flashing | | | □ - Off | |

- **Battery level indicator status (charging status)**

| LED 1 | LED 2 | LED 3 | LED 4 | Battery level |
|--|---|--|---|---------------|
|  |  |  |  | 0-25% |
|  |  |  |  | 25-50% |
|  |  |  |  | 50-75% |
|  |  |  |  | 75-100% |
|  - Indicator flashes in green | |  - Indicator is normally on green | | |

- **Additional functions**

Follow these steps to protect and prolong the battery service life.

- **Self-discharge protection for storage**

If the battery is stored in high temperature environment or it is not used for 6 days at a high battery level, the self-discharge protection will be activated. The battery will automatically discharge to a safe level, this is a default setting, and the discharging process takes 2-3 days. Although the battery has no indication in the self-discharge period, it is normal that the battery may be slightly hot. The discharge threshold can be manually defined with Autel Voyager.

- **Low battery protection**

In the case of low battery level, the battery will automatically enter sleep mode to avoid damage. Under this mode, there will be no reaction when pressing the power button. To wake up the battery, it must be connected with charger

- **Charging temperature detection**

The battery will stop charging if its temperature drops lower than 5°C(41°F) or rises higher than 45°C(113°F).

- **Overcurrent protection**

The battery will stop charging if the charging current exceeds 16A.

- **Overcharge protection**

The battery will automatically stop charging after it is fully charged.

- **Balanced protection**

Each battery unit shall maintain voltage balance to avoid overcharge or overdischarge.

➤ **Overdischarge protection**

The battery will automatically disconnect the power output function when it is not used and completes the self-discharge procedure. This function is disabled in flight.

➤ **Short-circuit protection**

The power supply will be disconnected if a short circuit is detected.

➤ **Power-down mode**

The battery will turn off if there is no operation within 30 minutes.

➤ **Communication**

During use, the aircraft will be continuously communicate with battery to provide the real-time information, including voltage, capacity, current, and temperature.

➤ **Low power consumption mode**

To save power, this mode will be activated when the battery is low and has not been charged for 1 day. After connecting the charger, the battery will resume normal functions.

2.1.5 Intelligent flight control system

Dragonfish Pro is able to conduct stable and convenient flight control by its built-in intelligent flight control system. This system can support multiple advanced functions, including course reversal, tracking, terrain following, etc. The working description of each module is as shown in the table below.

| Intelligent flight control system module | |
|---|---|
| Module | Description |
| IMU | Use one 3-axis gyroscope and 3-axis accelerometer to measure acceleration and angular speed. When the flight power switch is turned on, IMU will calibrate automatically. |
| Compass | Measure geomagnetic field and provide course reference of aircraft. |
| GNSS receiver | Receive the GLONASS signal to determine longitude, latitude and altitude. |
| Barometer | Measure atmospheric pressure to determine the altitude of aircraft. |
| Ultrasonic sensor | Measure the distance between aircraft and ground. |

● **Flight Mode**

According to GPS availability and flight conditions, Dragonfish Pro can automatically switch between two flight modes.

| Flight Mode | |
|--------------------|--|
| Flight Mode | Description |
| Automatic flight | The ground station is switched to gear A, and the aircraft performs a fully autonomous task flight without remote control. |
| Manual flight | The ground station is switched to gear M, the user can manually remotely control the flight, and the aircraft is located by GPS. |

2.1.6 Intelligent flight features

- **Intelligent tracking**

Intelligent tracking uses deep learning algorithms to automatically track selected target.

- **Pointed flight**

Select a target point in the camera interface frame, then Dragonfish Pro can fly to the target point at a speed and height.

- **Terrain following**

The route generated by the system can be automatically adjusted according to the elevation fluctuations of the terrain, ensuring that the altitude difference between the route and the ground is always at or above the set safe distance.

- **Auto return**

The return function is enabled only when there is good GPS signal. To enable the auto return function manually, press and hold the return button (Go Home) (🏠) on the remote controller for 3s. The aircraft will turn towards the return point and return according to the current setting.

- **Fail-safe**

The fail-safe function is to help Dragonfish Pro to return automatically or land at its current position when necessary. The fail-safe will be activated in the following situations:

- **Communication outage**

If the communication between the aircraft and the remote controller is interrupted, the fail-safe function will be activated.

If there is available GPS signal when the fail-safe function is activated, the aircraft will enable the auto return function. Otherwise the aircraft will land on the spot. After communication is restored, you can resume the control on the aircraft.

- **Low battery of aircraft**

In any of the following low battery situations, the fail-safe will be activated.

A. The aircraft will continuously calculate the battery level required to the return point. When the battery level reaches the maximum level required to the return point, The fail-safe will be activated and start the return process.

B. When the aircraft battery level reaches the set threshold (25% by default), you will receive one low battery alarm, and the fail-safe will be activated to start the auto return of aircraft. If you recover

the control on your aircraft, when the battery level reaches 15%, you will receive one serious low battery alarm, and the aircraft will automatically land on the spot. In emergency, you will need to manually make the aircraft fly to the nearest safe landing point.

● **Precise landing**

Dragonfish Pro integrates high-precision RTK modules and conventional GNSS modules to provide centimeter-level precise positioning. The aircraft scans and matches terrain features. If the current topography is matched with that at the take-off point, it will land as close to the take-off point as possible.

! Important

- The aircraft will record the take-off point as the default return point.
- Select an open and well-lit area (such as grass lawn) as the take-off point.
- When the aircraft is ready for landing, it is necessary to ensure that the take-off environment has no change.

2.2 Ground station

2.2.1 Portable ground station

Dragonfish Pro is equipped with a 9.7-inch TFT-LCD capacitive touch screen, with 2048*1536 ultra-high-definition resolution. The highest brightness is up to 1000cd/m², with a built-in 256G memory, the image transmission range is up to 30 kilometers, and the battery life is up to 4.5 hours. With a customizable interactive interface, it is simple to control, supports online parameter adjustment, route planning, and supports multiple control modes such as fully automatic and semi-automatic.

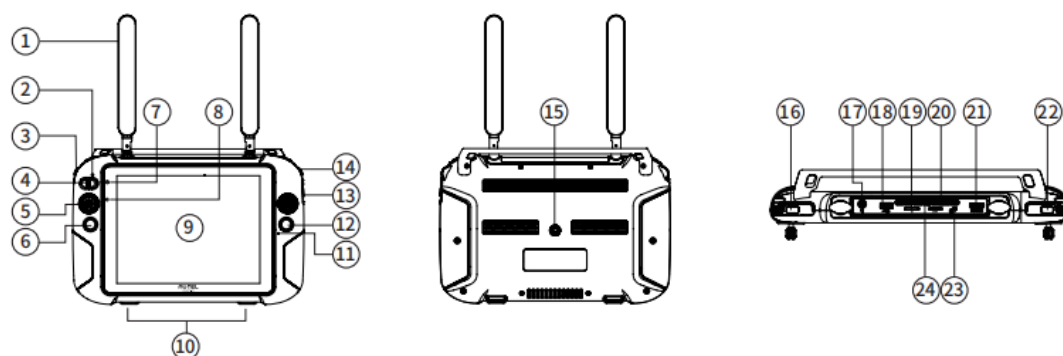

- | | |
|---------------------------------------|---------------------------------------|
| ① Antenna | ⑬ Zoom key |
| ② Mode switching indicator | ⑭ Gimbal levelness control thumbwheel |
| ③ Gimbal pitch control thumbwheel | ⑮ Tripod mounting interface |
| ④ Manual/automatic mode switching key | ⑯ Power button |
| ⑤ Rocker | ⑰ Charging interface |
| ⑥ Return button | ⑱ USB interface |
| ⑦ Power status indicator | ⑲ SD card slot |
| ⑧ Optical sensor | ⑳ SD card slot |

- ⑨ Touch display screen
- ⑩ Hook
- ⑪ Microphone
- ⑫ Shooting/video recording key
- ⑰ HDMI interface
- ⑱ User-defined key
- ⑳ Headphone jack
- ㉑ Air outlet

● **Ground station setting**

➤ **Rocker mode**

The rocker mode includes: Mode 1, Mode 2, Mode 3, you can switch the Rocker mode in the APP based on your own preference to control the aircraft. .

Method 1:

Enter the Autel Voyager App interface, click the flight status bar at the top of the main interface, and enter the aircraft setting.

Method 2:

Enter the Autel Voyager App interface, select "Task flight" or "Manual flight", enter the flight interface, click the gear icon (⚙️) in the upper right corner, and enter the aircraft setting.

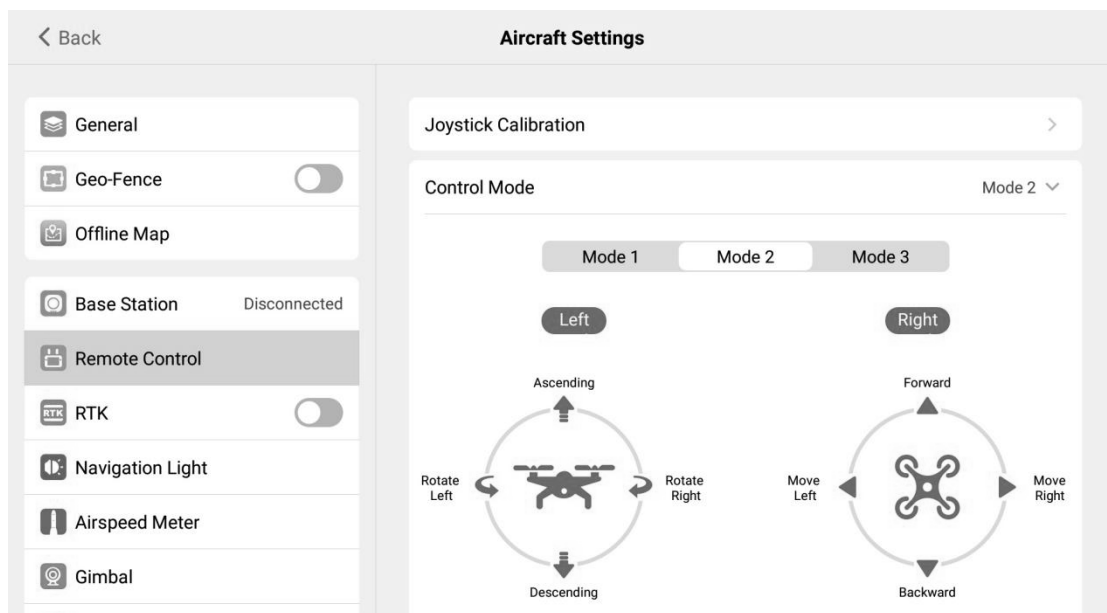

2.2.2 Autel Voyager App

Autel Voyager is flight control software specially designed for industry applications. It integrates multiple functions such as waypoint planning, intelligent tracking and flight history record, and more. Together with exclusive modeling software, it provides a one-stop solution for users.

- **App main interface**

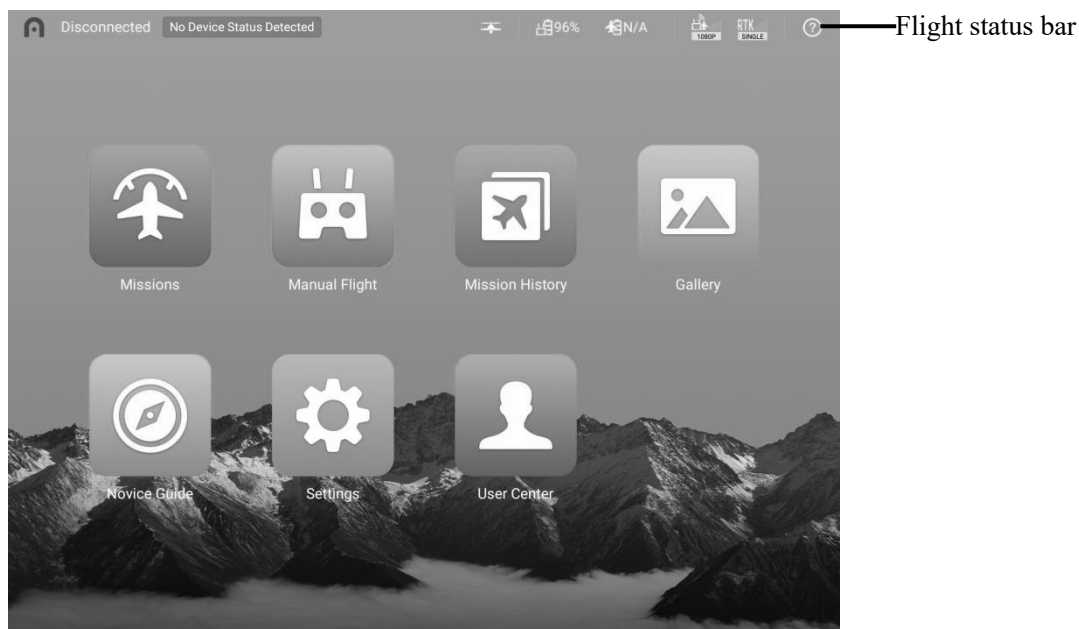

Missions: Waypoint task, polygon task and rectangular task can be added.



Manual flight: Switch the ground station to the gear M to enter into the manual control mode.

Mission history: Old tasks can be searched, and managed and edited.

Settings: Check the connection status of the base station, download offline maps, check software\firmware version updates, and report flight logs.





- **Flight status bar**

| Symbol | Status information |
|--------|--|
| 80% | Remote controller battery level |
| 80% | Aircraft battery level |
| 80% | Base station battery level |
| | WiFi signal intensity between base station and remote controller |

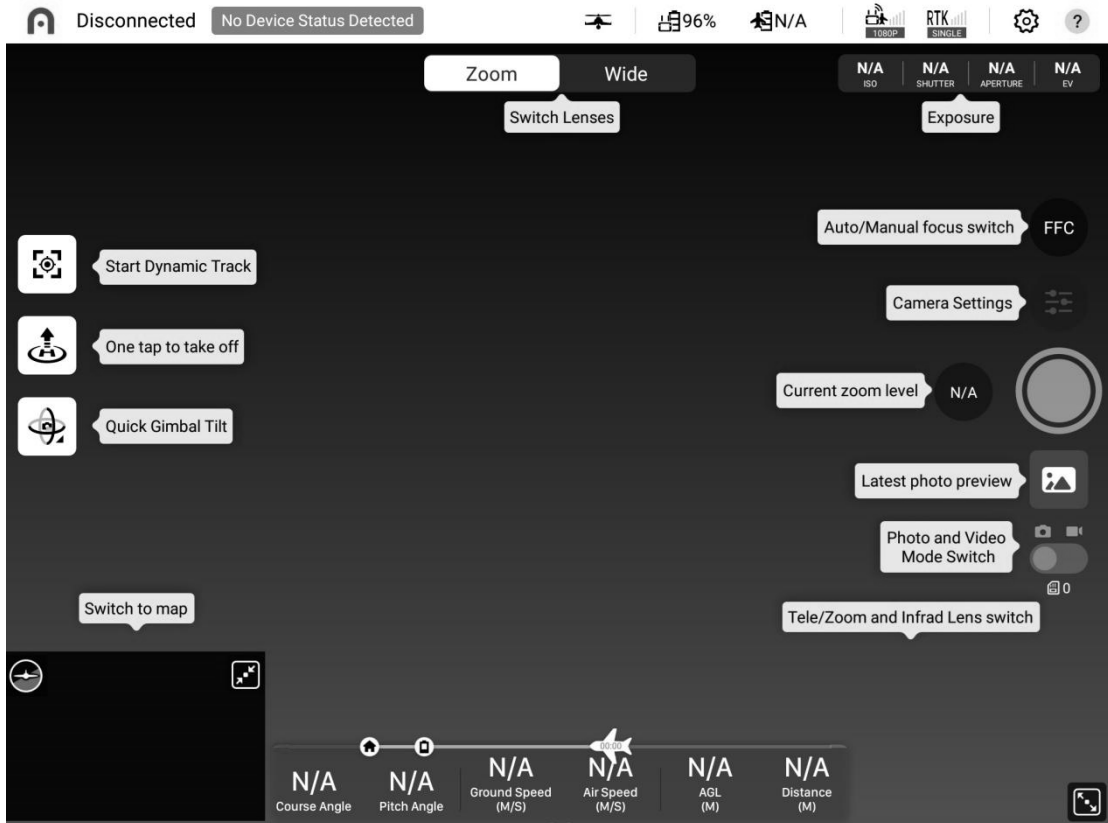
| | |
|---|-----------------------------------|
|  | Image transmission signal |
|  | Base station RTK satellite signal |
|  | Aircraft RTK satellite signal |







● **Camera interface**



| Symbol | Information |
|---|--------------------------|
|  | Start/exit tracking task |
|  | One-key takeoff |
|  | One-key landing |
|  | Gimbal angle switching |

● **Task interface**



| Symbol | Information |
|---|---|
|  | Map mode switching: Normal, hybrid, satellite |
|  | Rapid positioning: Remote controller position, aircraft position |
|  | Search: To search place name or address |
|  | In the center: Make the return point in the center of the screen |
|  | Elevation preview: Waypoint preview, check flight planning, turn on/off terrain following |
|  | Edit current task |
|  | Takeoff key, start the task |

Chapter 3

Flight preparation

Dragonfish Pro has a convenient rapid disassembly design. To ensure the safe operation of the UAV, please read the following instructions and warnings before the first flight.

3.1 Battery preparation

3.1.1 Aircraft battery charging

- **Charging**

Please connect one end of the charger to a 100-240V AC power supply, and connect the other end to the aircraft battery, as shown in the figure below.

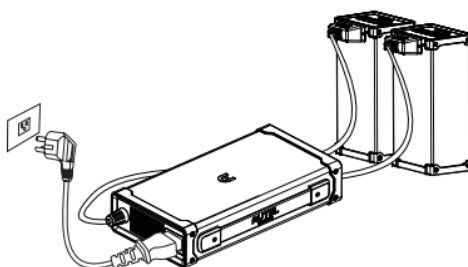

- **Remark**

- The charger is normally on green in the charging process of the aircraft battery. When the battery is charging, the LED light flashes in a flickering pattern. When the equalization mode begins, the green light flashes in a “breathing” pattern, and the light will show steady red in case of charging fault. At this time, the user can disconnect the power and try charging again. If the fault cannot be resolved, please contact your local dealer.
 - After the battery is fully charged, disconnect the charger from the battery.
-

3.1.2 Ground station battery charging

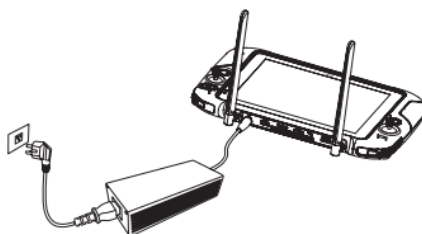

To charge the ground station, connect the round head line on the charger with the ground station.

- **Warning**

- Do not cover the charger during charging, to ensure normal cooling.

- Always place the charger in stable and safe position.
- During charging, do not touch the metallic casing of the charger, to avoid high-temperature scalding.

3.1.3 Base station charging

When using it for the first time, be sure to fully charge the battery. Please use dedicated charger to charge the base station.

1. Plug the Type-C power cord into the Type-C port of the base station. The base station will automatically enter into the charging mode (either when it is turned on or off).
2. During charging, the base station power indicator will flash, and the battery level will be indicated by different colors. When connected to the charging power supply, the base station power indicator is normally on green, indicating that it is fully charged.

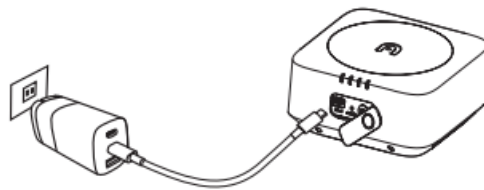

| | |
|--------------------|--------------------|
| Green | Battery level >60% |
| Yellow | Battery level >30% |
| Red | Battery level >10% |
| Red and slow flash | Battery level <10% |

3.2 Ground station preparation

3.2.1 Extend ground station

The ground station is folded in the packing box. Please carefully extend the antenna before use to prevent damage and ensure the best flight range.

- **Antenna position adjustment**

Keep the two antennas upright and parallel to each other to obtain best signals, as shown in the figure below.



3.2.2 Turn on/off ground station

- **Power on**

Press and hold the power button (⏻) for 2s until you hear a short beep. The flight information panel will light up, and startup inspection will commence.

- **Important**

- Always turn the remote controller on before turning on the aircraft's power.
-

- **Power off**

Press and hold the power button (⏻) for 2s until you hear a short beep.

- **Important**

- Always turn off the aircraft power before turning off the remote controller.
-

3.2.3 Frequency pairing of the aircraft and the ground station

The ground station and the aircraft have been paired in the factory. If they need to be paired again, please carry out the following operations:

1. Refer to the **Section of 2.2.1**, enter the aircraft setting interface, select the option of remote controller, and open the option of remote controller calibration.
2. Follow the prompts to remove the battery from the rear of the aircraft, press and release the battery button, and make sure the indicator is quickly flashing.
3. Click "Confirm after completing the above operations" on the App interface, and then click "Start connection".
4. Wait for frequency pairing. After frequency pairing succeeds, the battery indicator will flash slowly. Finally put the battery back to the aircraft.

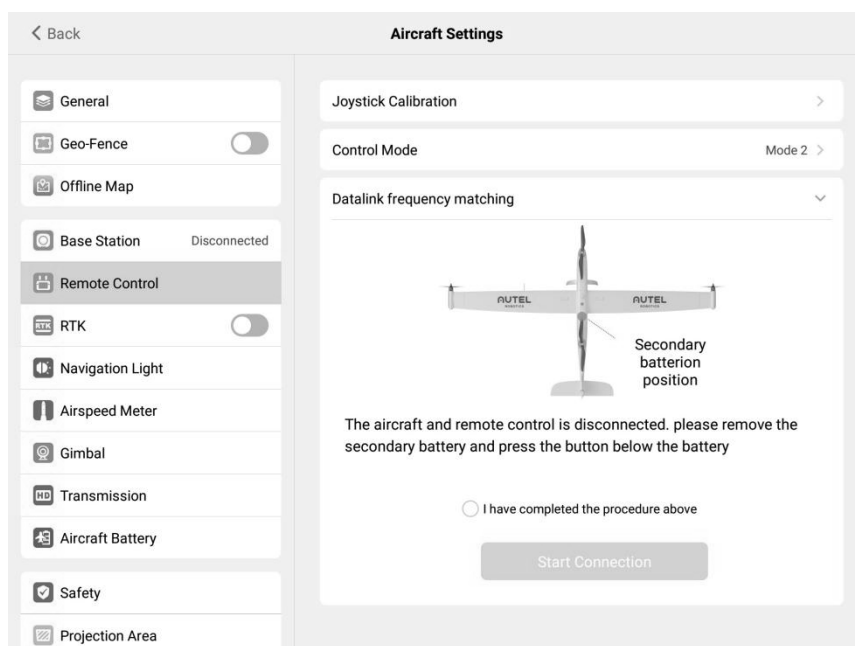

3.2.4 Ground station calibration

If the rocker is abnormal (for example, the ground station falls on the ground or the flight direction of the aircraft is not consistent with its operation direction), it is recommended to recalibrate the controller. You can calibrate the remote controller by using Autel Voyager App, or calibrate by the following steps.

1. Enter the aircraft setting interface, select the option of remote controller, and open the option of remote controller calibration.

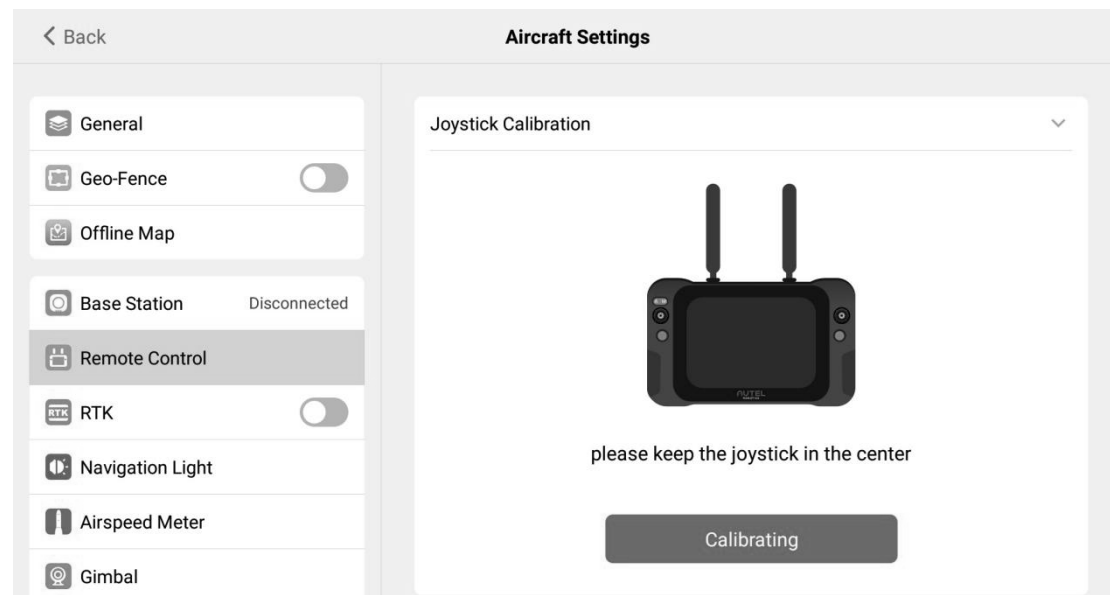

2. Select "Calibrate". The left and right rollers and left Right rocker legend will appear on the screen, and the remote control will emit a rapid and intermittent beep.

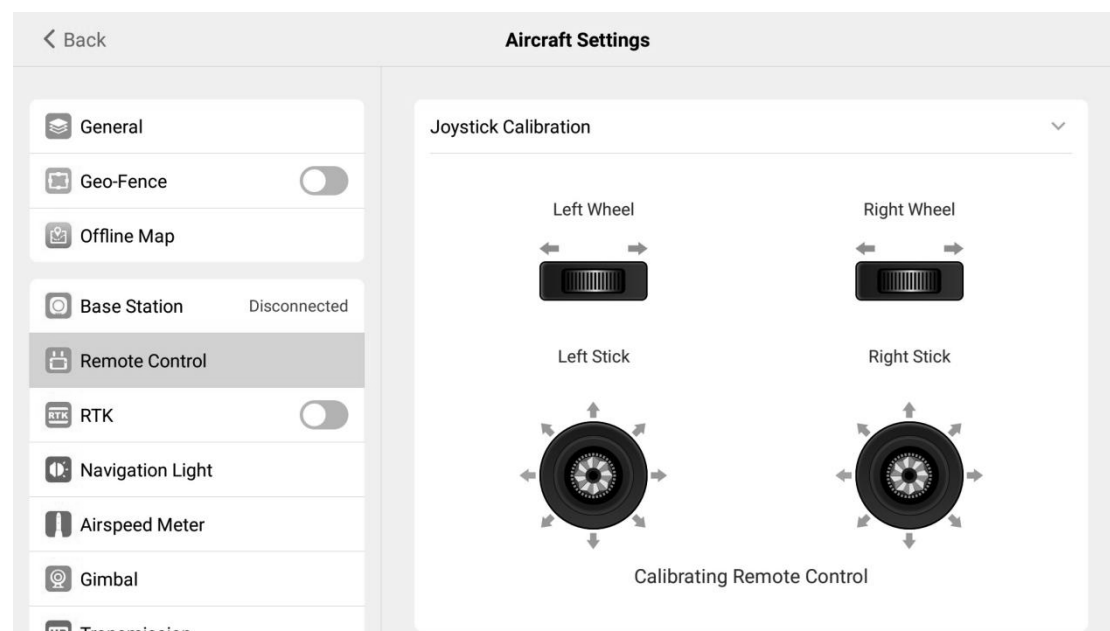

3. Follow the direction of the arrow on the screen, turn the roller clockwise and hold for 1 second until you hear a beep, then turn it counterclockwise until you hear a beep. Next push and hold the rockers in eight directions one by one until you hear a beep every time. When the ground station no longer emits the rapid and intermittent beep or the screen shows "Calibration completed", it means that the calibration has been completed.

3.3 Base station preparation

3.3.1 Base station construction

Set up the base station in a place with a wide view and mark it (align the center of the tripod with the center of the mark point), so that the base station can be accurately reset after being moved.

1. Unfold the tripod, extend three telescopic rods to proper lengths, and screw up the knob, to ensure that the tripod is firm.



2. Install the base station main body on the tripod and screw up the locking nut on the main body, to ensure that the base station is horizontal and firm.

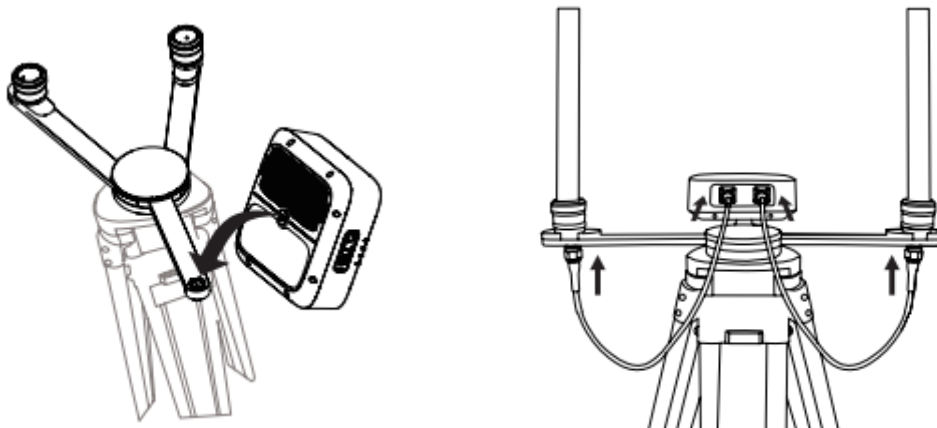

3. Install the antenna on the tripod, and connect the antenna feeder to the base station antenna port.

Remark

- After the tripod is leveled, do not change the position and angle of the tripod or base station, otherwise you will need to level it again.
- The base station must be set in an environment with a wide view, and ensure that there are no obstacles (trees, buildings) above 15° around the base station antenna, to avoid GNSS signals from being absorbed or blocked.
- The base station must be set in an environment at least 200m away from high-power radio sources (such as TV stations, and microwave stations), and at least 50m away from high-voltage transmission lines, to avoid electromagnetic field interference to GNSS signals.
- The base station must be set in an environment without large surface water or object which

may intensively interfere with satellite signal receiving, to reduce influence of multi-path effect.

- The base station must not be moved while the aircraft is in operation, otherwise the aircraft may be disconnected, and unexpected loss may occur.

Align and buckle

3.4 Aircraft preparation

3.4.1 Assemble aircraft

1. Install left and right wings

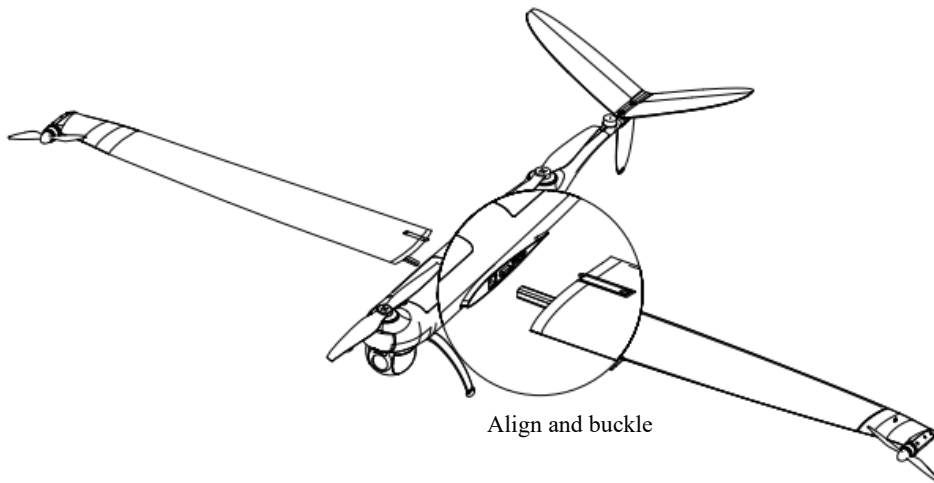

2. Install tail wing

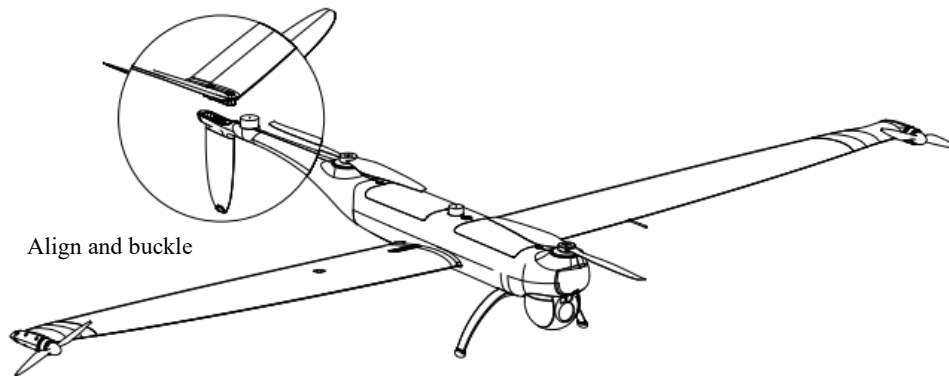

3. Install wingtip propeller

- Confirm that the aircraft has been turned off.
- Select the propeller matched for each motor.
- Forcibly press down the propeller and rotate it along the locking direction till it is installed firmly.

Warning

- Before installing or disassembling the propeller, please turn off the aircraft power switch .

Important

- Wear protective gloves when installing or disassembling the propeller.

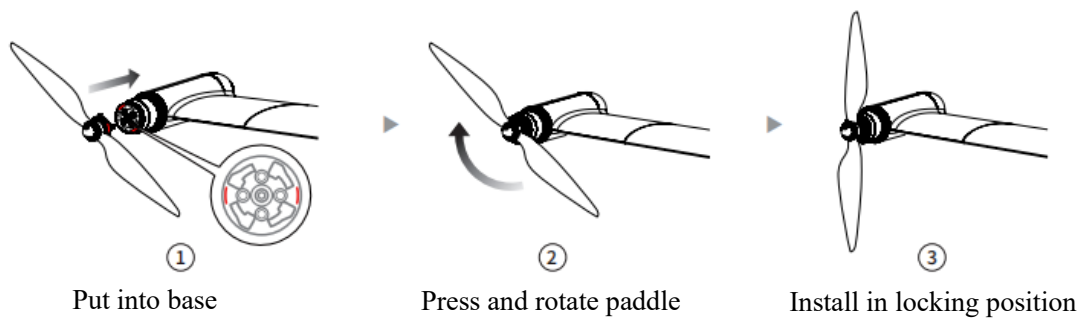

| | |
|--|---|
| | Locking direction: rotate in indicated direction to lock the propeller. |
| | Unlocking direction: rotate the propeller as indicated to unlock it. |
| | Install marked propeller on marked motor. |
| | Install unmarked propeller on unmarked motor. |

4. Install mount

Align the red spot on the mount with the red spot of the fuselage gimbal interface, and rotate the lock ring to the locking position.

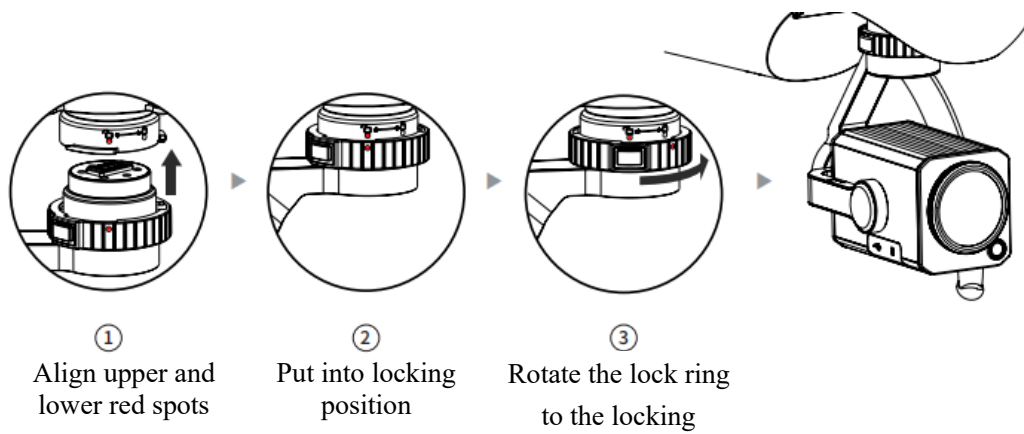

5. Unlock mount

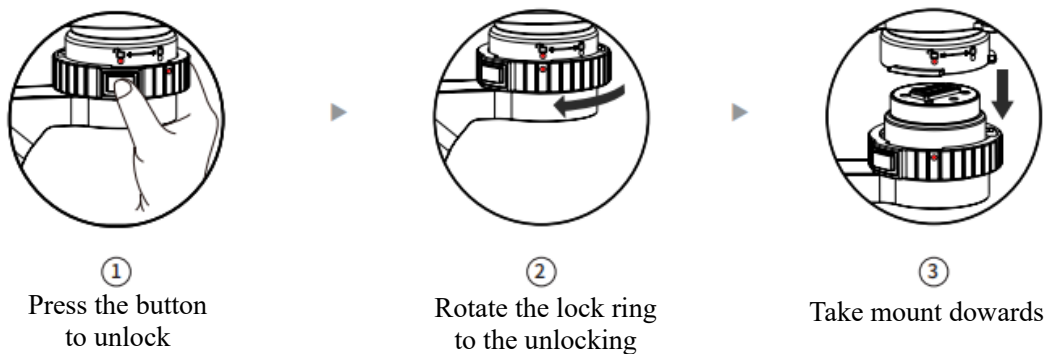

6. Install intelligent aircraft battery

When the aircraft battery is installed or removed, be sure to turn off the aircraft power. Align the battery port with the battery port on the fuselage, put in the battery until you hear a click.

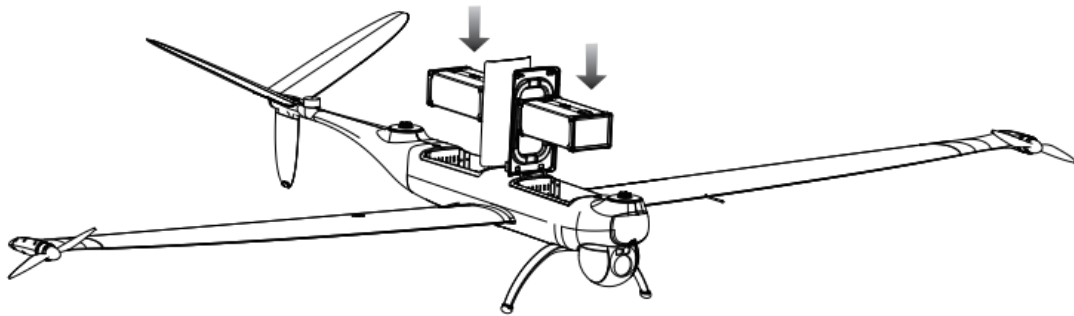

3.4.2 Activate aircraft

1. Turn on the ground station power supply

Press and hold the power supply button for 1s to turn on the ground station power supply.

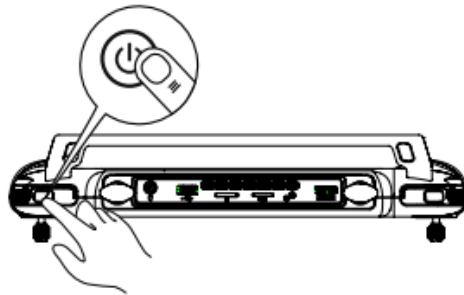

2. Turn on the base station power supply

Press and hold the power supply button for 1s to turn on the base station.



3. Turn on the aircraft power supply

Press and hold the fuselage power supply button for 3s to turn on the aircraft power supply

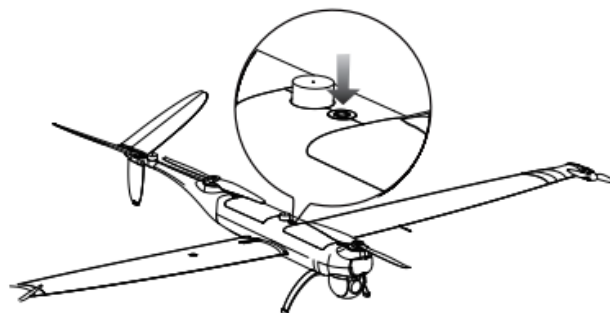

4. Activate aircraft

Turn on Autel Voyager and click the activation button to activate the aircraft.

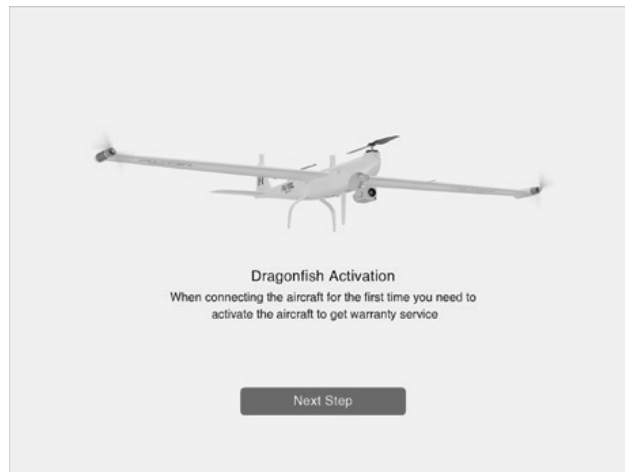

5. Airspeedometer calibration

1. Enter the aircraft setting interface, select the airspeedometer option.
2. According to the prompt, cover the airspeed tube with calibrator.
3. Click “Confirm” after completing the above operations on the App interface, then click “Start calibration” and wait for calibration completion.

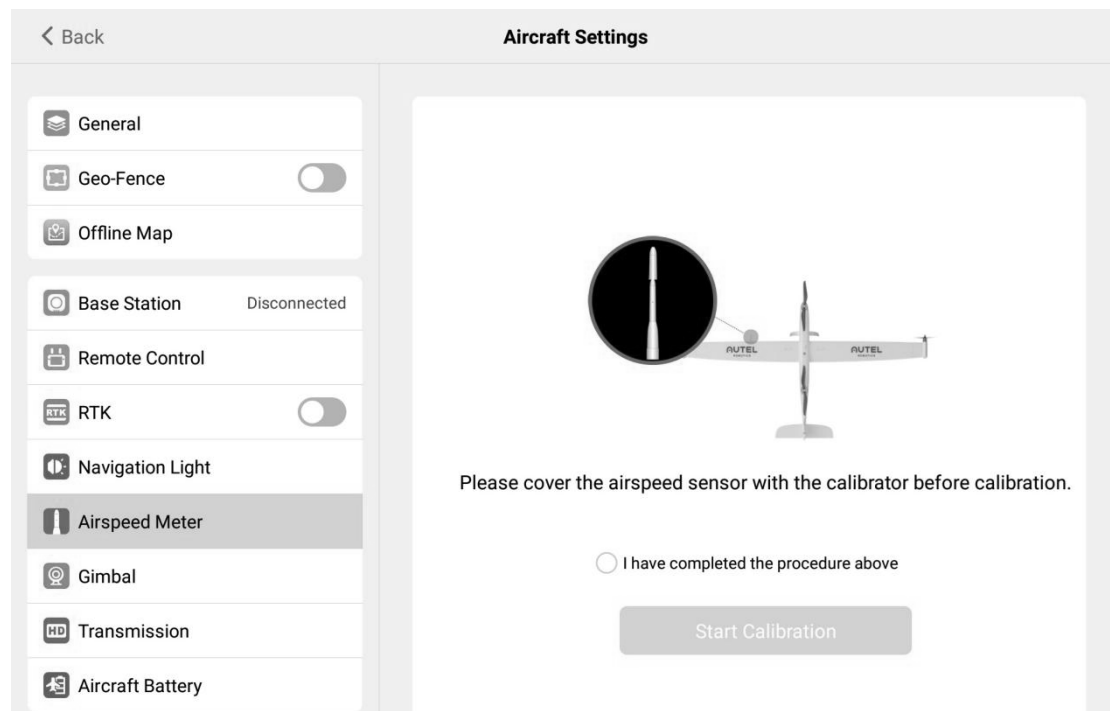

3.5 Flight

Enter the Autel Voyager safe flight interface display. Before takeoff, please place the aircraft on a flat ground with the tail of the aircraft facing you.

3.5.1 Manual takeoff

1. Switch the ground station to the gear M

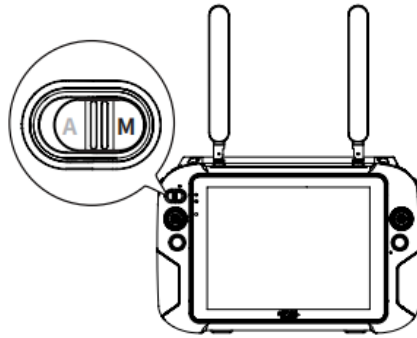

2. Check the aircraft system state

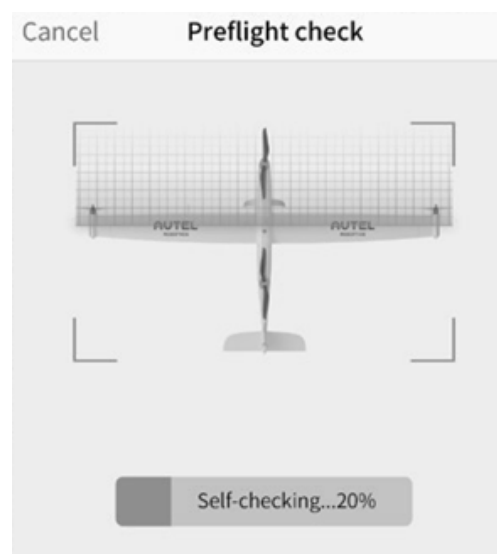
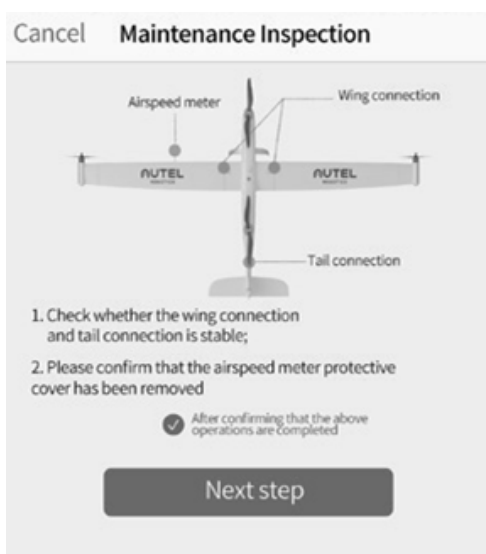

3. At the same time, press the left and right rockers inwards or outwards, and hold for 2 seconds to unlock the motor

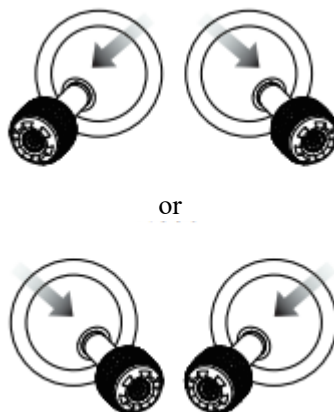

4. Push the accelerator rocker up, then the aircraft will rise.



⚠ Warning

- The manual mode is not recommended for non-professionals.
-

3.5.2 Automatic takeoff

1. Switch the ground station to the gear A

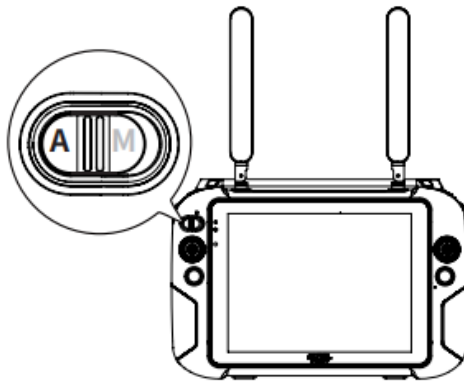

2. Click the task creation button to plan flight tasks

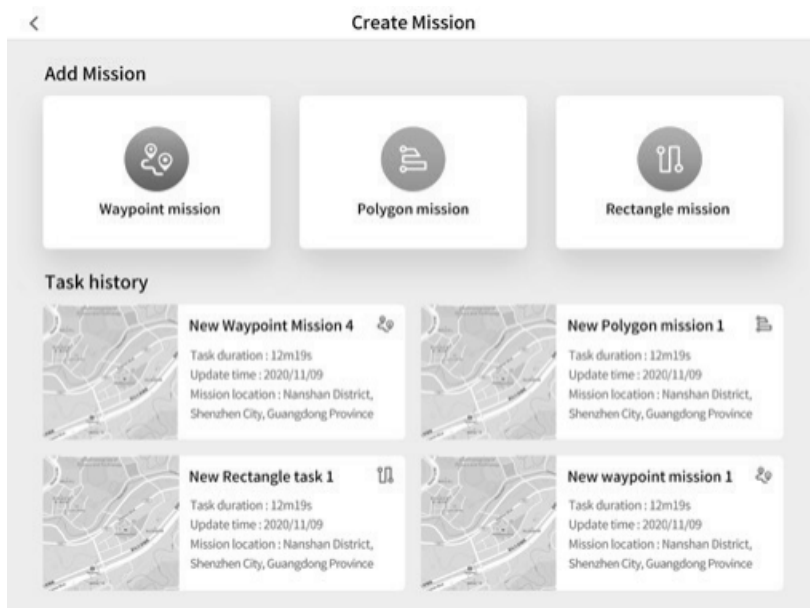

3. Check the aircraft system state

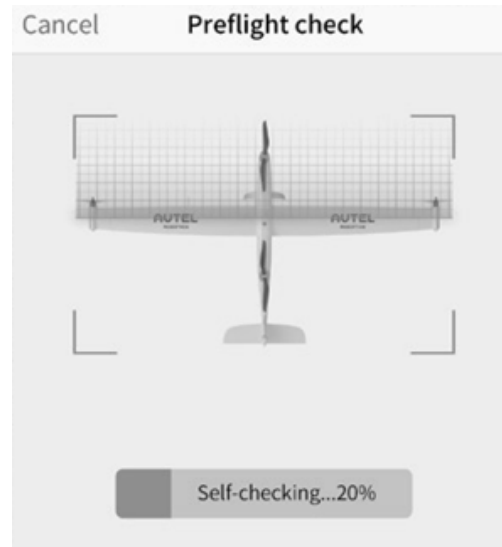
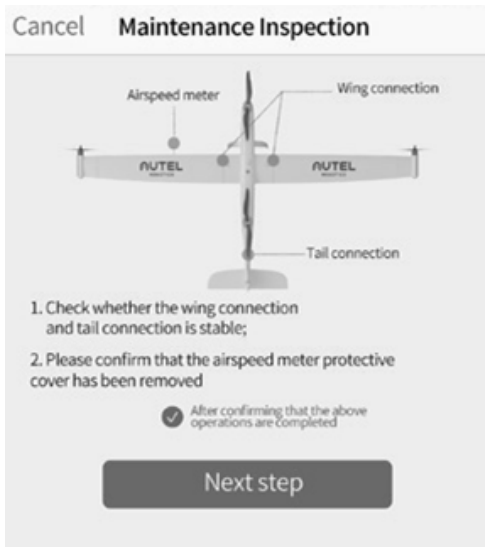

4. Display the flight interface

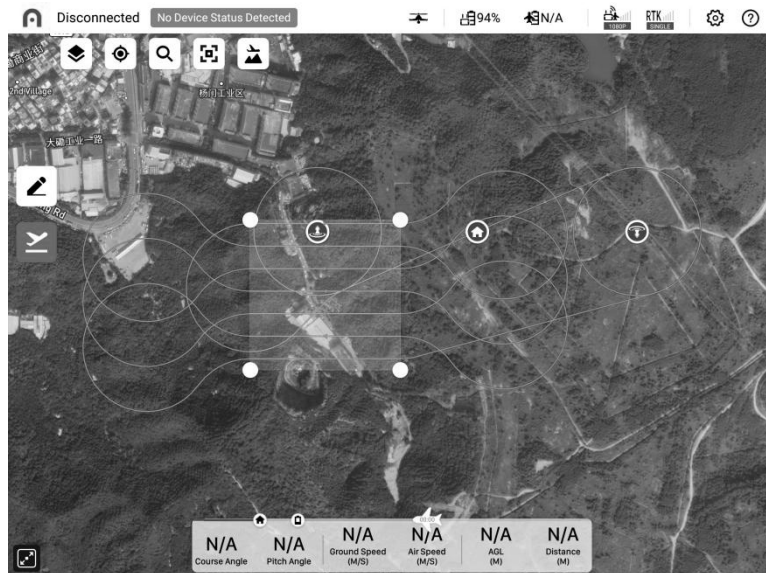

Chapter 4

Flight Operation

4.1 Precautions

- **Check list before flight**

Perform comprehensive check before flight by the following steps:

- Fully charge the aircraft battery, the ground station battery and the base station battery.
- Confirm that the propeller is intact and correctly installed.
- Set the position of the ground station antenna.
- Pair the aircraft, the ground station and the base station.
- Check that the firmware has been upgraded to the latest version indeed.
- Ensure that you are familiar with flight control operation.
- Make sure the flight area is open without obstacles.
- Check the weather, including the window and the wind speed.
- Make sure the camera lens and sensor of the aircraft is clean.
- Please use original parts. Using non-original parts may be dangerous to the aircraft.

- **Warning**

To avoid illegal acts and possible injuries and losses, the following items must be followed:

- Avoid using the aircraft in densely populated areas;
- It is forbidden to fly in the restricted area. Restricted area include: airports, borders and major cities;
- It is forbidden to use aircraft to carry any illegal dangerous goods;
- It is prohibited to fly over or near sensitive buildings and facilities without permission, including but not limited to, power stations, hydroelectric power stations, prisons, traffic arteries, government buildings, and military installations.

- **Requirements on flight environment**

- Do not fly in bad weather, such as strong wind (wind speed above level 6), rain, snow, etc.
- The takeoff and landing site must be far away from densely populated areas, but with good visibility, and without high-voltage lines, tall buildings, important facilities, etc. around;
- There should be no sources of interference, such as radar stations, microwave relays and wireless communications near the takeoff and landing site. In the case of uncertainty, test the frequency and signal strength. If there is interference to the system equipment, change the takeoff site;
- The takeoff and landing site must be relatively clean and flat. Please ensure that the takeoff and landing site has no obvious raised rocks, ridges, tree stumps, ponds, ditches or sharp protrusions in the immediate area.

- **Important**

- The takeoff site must be more than 20km away from military and commercial airports and other restricted areas.

4.2 Ground station and flight operation

This aircraft includes three rocker modes: Mode 1, Mode 2 and Mode 3. Each mode has different control on the aircraft. The default mode is the Mode 2.

- **Mode 2**

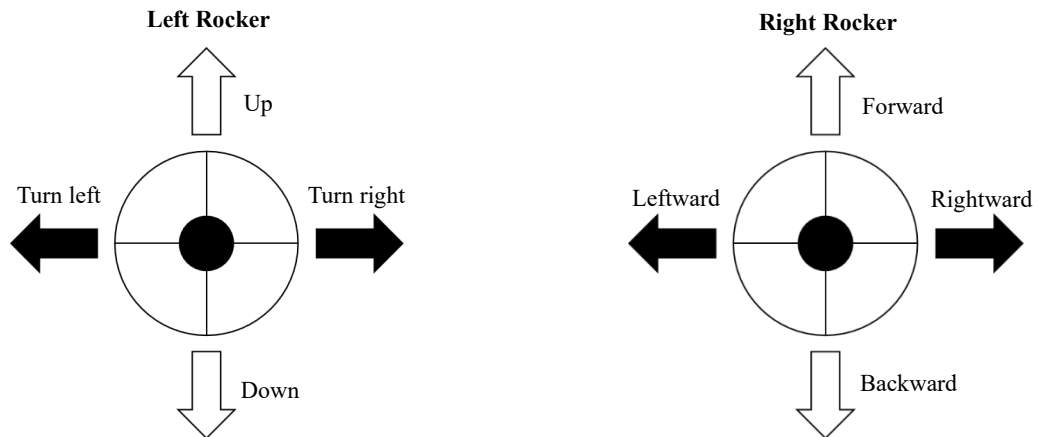

- **Mode 1**

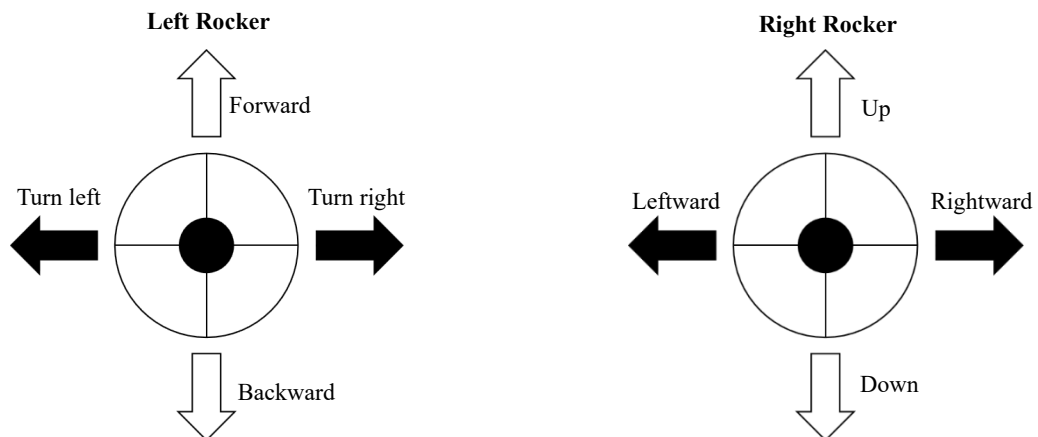

- **Mode 3**

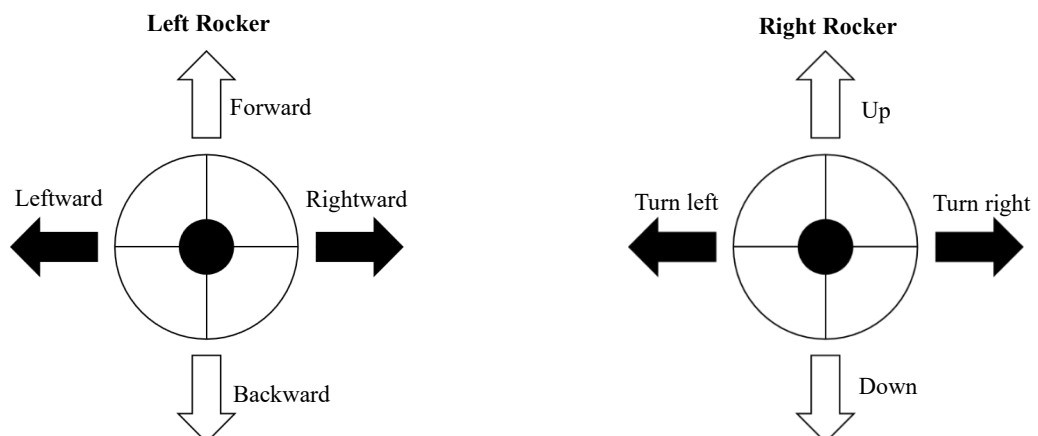

 **Remark**

- The accelerator rocker is used to control the aircraft to raise and descend.
-

 **Reminding**

- The rocker modes, which can be switched in the **Autel Voyager**, can be selected according to operation habits, and the American manipulator is recommended for the beginner.
-

- **Basic flight**

1. Place the aircraft in an open area. Stand at least 5 m (15 ft) from the tail of the aircraft.
2. Turn on the ground station.
3. Turn on the aircraft.
4. Start the motor with the ground station to take off.
5. Carefully navigate and manipulate the aircraft.
6. Land down the aircraft, and turn off the motor.

4.2.1 Motor start and aircraft take off

 **Remark**

- The aircraft cannot fly when the battery level is 15% or below.
 - When the power level difference of the two batteries is greater than 12%, the APP will issue a warning to restrict the aircraft from taking off.
-

- As shown in figure, press the left and right rockers for 2s to start motor:

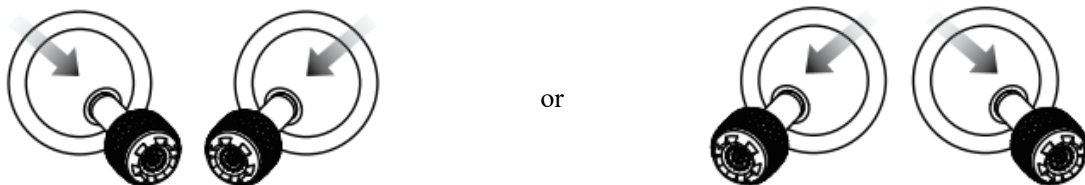

- Push the throttle rocker upwards slowly



 **Warning**

- Motor will generate heat during operation. Please operate with care.
-

4.2.2 Manipulator control (Mode 2)

 **Reminding**

- If you are the first time to control the aircraft, please move the rocker gently till that you are familiar with its operation.
-

- **Left rocker**

- **Raising/descend**

Push the rocker up and down to control the ascent and descent of the aircraft.

- **Rotate leftwards/rightwards**

Push the rocker leftwards or rightwards to rotate the aircraft left or right.

- **Right rocker**

- **Forwards/backwards**

Push the rocker forwards and backwards to move the aircraft forwards and backwards.

- **Move leftwards/rightwards**

Push the rocker leftwards or rightwards to move the aircraft left or right.

4.2.3 Landing and motor off

Dragonfish Pro can be manually, automatically or passively landed. Steps to operate the aircraft to land down by using the three methods are as follows:

 **Important**

- Always land on a flat and open surface.
-

- **Manual landing**

You can use the remote controller's rocker to manually land the aircraft anytime and anywhere.

- **Move leftwards/rightwards**

1. Find an appropriate aircraft landing position.
2. When the aircraft arrives above the target position, release the rocker to make the aircraft hover.
3. Slowly push down the left rocker to land the aircraft.

- **Turn off the motor**

When the aircraft lands on the ground, select one of the following methods to turn off the motor:



or

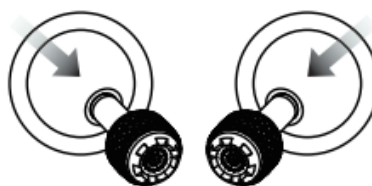

Push the throttle rocker to the bottom and hold in the position for 2s

Push two rockers inwards and hold in the position for 2s

- **Automatic landing**

Click the One-key landing (), on the App camera interface. The aircraft will automatically descend, land and turn off the motor. During the descending process, you can adjust the aircraft position by using the right rocker.

- ✎ **Remark**

- In the case of low battery alarm (25%), it is necessary to return to the safe landing point as soon as possible.

- **Passive landing**

When any of the following conditions are met, the fail-safe protection will trigger and the aircraft will automatically land at its current position.

- **The low battery alarm** can be activated in a non-GPS environment.
- **The very low battery alarm** is activated.

Chapter 5

Maintenance and service

5.1 Firmware update

In order to optimize the system performance of Dragonfish Pro aircrafts, Autel Robotics will update relevant firmware when necessary. When the system detects a new firmware version, Autel Voyager APP will open a prompt box after it is connected with the aircraft to remind you to download and install the new version.

1. Turn on the ground station power supply and the power supplies of the base station and the aircraft.
 2. Select the opening "Setting" (⚙️) on the ground station main interface, then select "Software update" (⬇️), and finally select "UAV firmware" (✈️) to download firmware.
 3. After the firmware is downloaded, select installation, then firmware upgrade is completed.
 4. Restart the remote controller and the aircraft before use.
-

! Important

Before firmware update, please ensure that:

- The aircraft motor is not powered on.
 - The power levels of the aircraft and the remote controller are not lower than 25%.
-
-

! Important

- During the update process, do not turn off the aircraft or the ground station, start the motor, or remove the USB flash disk from the ground station.
 - After the upgrade, the ground station may be disconnected from the aircraft, please pair them again.
-

5.2 Solutions to common faults

Q1. The aircraft displays a fault during the self-inspection:

- Hardware problems are detected. Please contact the Autel Robotics' customer support here: www.autelrobotics.com/page/contact

Q2. If the motor cannot be started, please check the following:

- Whether the remote controller and the aircraft are paired.
- Whether the remote controller is correctly calibrated.
- Whether the aircraft battery is fully charged.
- Whether the compass is correctly calibrated.
- Whether the GPS can be used.

Q3. If the aircraft cannot take off after the motor is started, please check the following:

- Whether the aircraft is in a restricted area.
- Whether the aircraft is on a flat surface.

Q4. The flight time is shortened:

- The most common reason for shortened flight time is the influence of low ambient temperature, wind strength, etc.

Q5. The aircraft does not respond to the remote controller during pairing:

- Confirm that there is no metallic object, mobile device or other remote controller nearby.

Q6. The video link has fault or is frequently disconnected:

- Confirm that there are no sources of magnetism or signal interference around the aircraft and remote controller.

Q7. The video link is disconnected when the aircraft is not in visual range:

- Activate the auto return instruction to return the aircraft to the return point.

Q8. The video is tilted during flight:

- Calibrate the gimbal according to the "Automatic Gimbal Calibration" function in the APP.
- If the problem is still not solved, adjust the gimbal according to the instructions in the "Gimbal Fine Tuning" function.

Q9. The lens of the camera is stained:

- Please wipe the lens with the glasses cloth gently. It is recommended to use the glasses cloth provided in the packing box.

5.3 Storage and maintenance

In order to ensure the optimal performance of Dragonfish Pro, please read and follow the maintenance instructions in this section carefully.

- Store the aircraft, battery and remote controller in a clean, dry, cool and well-ventilated place.
- Protect the aircraft from direct sunlight when it is not used.
- Please dry your hands before operating the aircraft.
- Clean the camera lens with the soft cloth with alcohol or gentle window cleanser. Do not use any strong cleanser, detergent or chemical.
- Keep the battery charger clear of other conducting materials.
- Avoid dropping the aircraft and its accessories, especially falling on a hard surface. Carefully check all components after each collision or impact. Please contact Autel Robotics customer support for any damage.
- Only use the accessories authorized by Autel Robotics, such as the charger. We will provide no warranty for any accident due to the use of unapproved accessories.

5.4 Warranty

Autel Robotics Co., Ltd (hereinafter referred to as the "Company") promises to the original retail purchaser of this product: under normal conditions of use, if this product or any part is proved to have defects in materials or process that cause equipment failure, within the warranty period (from the date of delivery), the Company will repair or replace products or parts for you free of charge

according to actual situations with the proof of purchase.

Scope of service:

- Within the warranty period, the product has the non-human performance fault during normal use;
- The product is not disassembled without approval or modified or added as instructed by non-official manual, or has other non-human faults;
- The equipment serial number, factory label and other marks are not torn away or altered;
- The effective proof of purchase, document and document number are provided;

This warranty clause will not be applied:

- When the product is out of the warranty period;
- When the battery has been charged for more than 200 times;
- When the product doesn't use the official latest firmware;
- When the fault is caused when product is used for unlawful activities;
- When the product flight log has been changed or deleted without approval;
- When the serial number label and waterproof mark of the product are damaged or altered;
- When the product has appearance, decorative or structural (such as frame and non-operating component) defects;
- When the damage is caused because it is not installed, used and operated as instructed by the manual;
- When the product damage is caused because of the use of the self-programming or non-official software;
- When the damage is caused by the reliability and compatibility problems when the product is used with the component of a third party other than Autel;
- When the product suffers from abnormal use or environment, accident or improper handling, unauthorized change, abuse, or improper installation, maintenance or storage;
- When the product is damaged due to external factors, including but not limited to, natural disaster, fire, water, dirt, dust, battery leakage, fuse burn-out, theft or any improper use of power supply;
- When user fails to send the product within 7 natural days after contacting Autel for warranty service.

5.5 Customer service

This section includes the information on technical support, maintenance service, application for replacement and spare parts.

5.5.1 Technical support

If you have any problem or question about our product, please contact the customer support of Autel Robotics:

North America/Europe

Tel: (844) 692-8835

Email : after-sale@autelrobotics.com

Website: www.autelrobotics.com

China

Tel: 0755-2690 8091

Email : after-sale@autelrobotics.com

Website: www.autelrobotics.cn

5.5.2 Maintenance service

If you want to return your equipment for repair, please mail to Email : after-sale@autelrobotics.com or call Autel Robotics' customer support: 400-800-1866.

You will need to provide the following information:

- Name
- Email
- Mailing address
- Phone number
- Product name
- Complete problem description and photo
- For warranty: provide the proof of purchase
- For non-warranty: provide the preferred payment mode

The customer support personnel at Autel Robotics will evaluate the problem and give a reply within 2 days.



Remark

- All contents of the product may be deleted during maintenance. You are advised to create a backup copy for the product before delivering it for warranty service.
-

Chapter 6

Annex

6.1 Restricted area and indexes of laws and regulations

6.1.1 Diagram of restricted area

Dragonfish Pro UAV can automatically identify restricted areas and avoid these areas by default during flight. This function ensures that the aircraft complies with the legal flight area requirements.

Flight restrictions are only enforced in some countries with mandatory legal requirements, such as China. China is the only country that requires manufacturers to enforce flight restrictions.



Remark

- Operator shall abide by all the local rules and regulations concerning flight.

The restricted area is classified into two classes:

Class I: main airport & low-altitude area for manned aircraft

I: Warning area

APP will give a warning information when the aircraft enters the area of 8.1km from the airport.

II: Height limit area

An annular area centered on this area and with a radius of 2.4-8km. The flight height of the aircraft is limited and such height limit varies with the radius. When the radius decreases from 8km to 2.4km, the maximum flight height will decrease from 120m to 10.5m.

III: Restricted area

A circular area centered on this area and with a radius of 2.4km (subject to government rules).

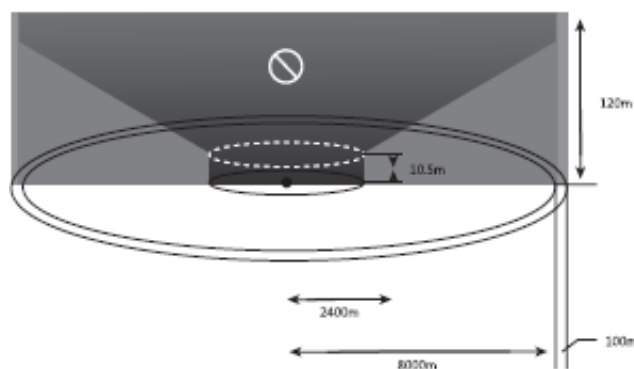

Class II: Sensitive area or organization & military area & border between countries

I: Warning area

APP will give a warning information when the aircraft enters the area of 2 km from the airport.

II: Restricted area

A circular area centered on this area and with a radius of 1km.

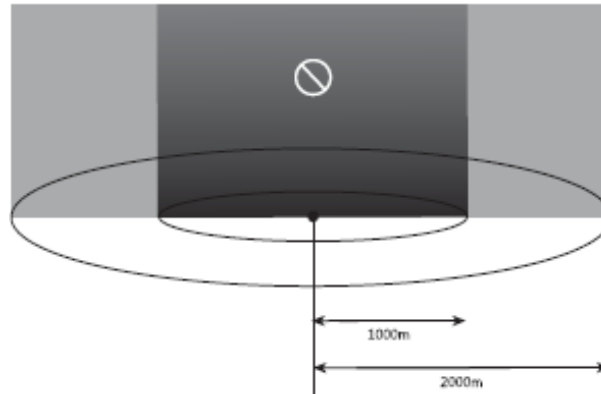

Remark

- When the aircraft enters any takeoff restricted area, it will land automatically. When the aircraft enters the altitude restricted area, its maximum allowable altitude will be lowered accordingly. Please pay special attention to the warning message displayed by Autel Voyager App.
-

6.1.2 Indexes of laws and regulations for Chinese UAVs

Users of UAVs must check local regulations before flying, and perform flight tasks under legal and safe conditions. The following is a list of regulatory documents in China for your reference. Users in overseas regions shall find local regulations by oneself.

1. Legal Laws and regulations

- Civil Aviation Law of the People's Republic of China (Order of the President of the People's Republic of China [1995] No. 56), promulgated on October 30, 1995, implemented on March 1, 1996, and last revised on December 29, 2018.

2. Administrative laws and regulations

- Military Airport Clearance Regulations (G. F (2001) No. 29), promulgated on August 12, 2001, and implemented on August 12, 2001.
- The Basic Flight Rules of the People's Republic of China (Order No. 312 of the State Council), promulgated on July 27, 2001, implemented on August 1, 2001, and last revised on October 18, 2007.
- General Aviation Flight Control Regulations" (Order No. 371 of the State Council and the Central Military Commission).
- The Regulations on the Administration of Civil Airports (Order No. 553 of the State Council), promulgated on April 13, 2009, implemented on July 1, 2009, and last revised on March 2, 2019.

2. Normative documents

- Civil Unmanned Aircraft System Air Traffic Management Measures MD-TM-2016-004 (Bureau Invention Electric (2016) No. 2630), promulgated on September 21, 2016, and implemented on September 21, 2016.
 - Regulations on the Operation of Light and Small UAVs (Trial) AC-91-FS-2015-31, promulgated on December 29, 2015, and implemented on December 29, 2015.
 - Civil UAV Pilot Management Regulations AC-61-FS-2016-20R1, promulgated on July 11, 2016, implemented on July 11, 2016, and last revised on August 31, 2018.
 - Regulations on the Administration of Real-Name Registration of Civil Unmanned Aircraft AP-45-AA-2017-03, promulgated on May 16, 2017, and implemented on May 16, 2017.
-



Remark

- The above only lists the currently effective laws, regulations and normative documents most relevant to UAVs in China (temporarily not including regions of Hong Kong, Macau and Taiwan), and does not guarantee that all regulatory documents are covered. Customers must check and confirm the laws and regulations by themselves based on the operating area and the use purpose of UAV products.
-

6.2 Specifications

| Aircraft | |
|--|---|
| Size | 1.65*3.04*0.46 m |
| Weight (including two batteries, excluding the gimbal) | 14.5 kg |
| Weight of single battery | 3.6kg |
| Maximum takeoff weight | 17 kg |
| Max. loading capacity | 2.5kg |
| Working frequency | 902-928 MHz; 2.4000-2.4835 GHz; 5.725-5.755GHz |
| Transmit power (EIRP) | 900MHz FCC: < 30 dBm; 2.4 GHz FCC: < 30 dBm SRRC/CE/MIC: < 20 dBm; 5.8 GHz SRRC/FCC: < 22 dBm CE: < 14 dBm |
| Max. flight time (wind-free environment) | 158 min |
| Max. horizontal flight speed | 30 m/s |
| Max. takeoff speed | Vertical flight mode: 4 m/s Fixed wing flight mode: 5 m/s |
| Max. landing speed | Vertical flight mode: 3 m/s Fixed wing flight mode: 5 m/s |
| Max. takeoff altitude | 6000 m |
| Max. wind resistance | In flight with fixed wing: 15 m/s (Grade 7) In vertical takeoff and landing: 12 m/s (Grade 6) |
| Max. pitch angle | 20° |
| Max. rolling angle | 35° |
| Max. angular velocity of rotation | Pitching axis: 180°/s Heading axis: 60°/s |
| Working temperature scope(° C) | -20° C to 50° C |
| Adaptive mount | DG-Z2, T3, T3H, L20T, L50T |
| Supported gimbal installation mode | Rapid disassembling |
| IP Protective class | IP43 |
| GNSS | GPS+GLONASS+BeiDou+Galileo |

| | |
|------------------------|--|
| Hover precision(P-GPS) | Vertical: ± 0.1 m (vision positioning works normally) ± 0.5 m (GPS works normally) ± 0.1 m (RTK positioning works normally) Horizontal: ± 0.3 m (vision positioning works normally) ± 1.5 m (GPS works normally) ± 0.1 m (RTK positioning works normally) |
| RTK position accuracy | In RTK FIX: 1 cm+1 ppm(horizontal) 1.5 cm + 1 ppm(vertical) |

| Millimeter-wave Radar | |
|------------------------------|----------------------------------|
| Transmit Frequency | 79-81GHz |
| Output Power (EIRP) | 27dBm |
| Modulation Type | FMCW |
| Cycle Time | 50ms |
| Communication Interface | UART |
| Distance Range | 0.75-275m |
| Distance Accuracy | ± 0.1 m |
| Beam Width (-6dB) | 30° (azimuth) 30° (elevation) |

| Image transmission of ground station | |
|--|--|
| Working frequency | 902-928 MHz;2.4-2.4835 GHz |
| Max. desired signal distance (no interference, no blockage) | FCC: 10 km CE / MIC: 5 km SRRC: 5 km |

| Data transmission of ground station | |
|--|-------------------|
| Working frequency | 5.725 - 5.755 GHz |

| Wi-Fi of ground station | |
|--------------------------------|---|
| Protocol | Wi-Fi Direct, Wi-Fi Display, 802.11a/g/n/ac Support 2 x 2 MIMO Wi-Fi |

| | |
|-------------------|---|
| Working frequency | 2.400 - 2.4835 GHz 5.150 - 5.250GHz 5.650 - 5.755GHz 5.725 - 5.850 GHz |
|-------------------|---|

| Others specs of ground station | |
|--|---|
| Battery | Name: lithium polymer battery Capacity: 8200mAh Voltage: 11.4 V Battery type: Li-Po Energy: 93 Wh Charging time: 120 minutes |
| Battery life | About 3 hours (maximum brightness) About 4.5 hours (50% brightness) |
| Memory space | ROM 256GB + extensible (support TF card) |
| Video output interface | HDMI |
| USB-A interface power supply voltage/current | 5V / 500m A |
| Operating ambient temperature | -20° C to 40° C |
| Storage ambient temperature | -20° C to 60° C (within one month) -20° C to 45° C (within three months) -20° C to 30° C (within one year) |
| Charging ambient temperature | 0° C to 45° C |
| Satellite positioning module | GPS+GLONASS+Galileo |
| Size | 319×233×74 mm (folded antenna) 319×398×74 mm (unfolded antenna) |
| Weight | 1987g |

| GNSS receiver of base station | |
|--------------------------------------|---|
| Satellite receiving frequency | Synchronous receiving: GPS: L1, L2, L5 BeiDou: B1, B2, B3 GLONASS: F1, F2 Galileo: E1, E5A, E5B |
| Positioning accuracy | Single point Horizontal: 1.5 m(RMS) Vertical: 3.0 m(RMS) RTK Horizontal: 1 cm+1 ppm(RMS) |

| | |
|---|---|
| | Vertical: 1.5 cm+ 1 ppm(RMS) 1 ppm: For every increase of 1km, the accuracy is decreased by 1mm. For example, the precision is 1.1cm when the aircraft is 1km away from the base station. |
| Positioning update rate | 1Hz, 2 Hz, 5 Hz, 10 Hz and 20Hz |
| Cold startup | <40s |
| Warm startup | <10s |
| Recapture | <1s |
| Initialization reliability | > 99.9% |
| Differential data transmission format | RTCM 2.X/3.X |
| Data link | Image transmission link; WiFi |
| Image transmission of base station | |
| Working frequency | 2.4000-2.4835 GHz;902-928 MHz |
| Effective Isotropic Radiated Power(EIRP) | 902-928 MHz FCC: < 30 dBm 2.400-2.4835 GHz FCC: < 30 dBm SRRC/CE/MIC: < 20 dBm |

| | |
|--|---|
| Wi-Fi of base station | |
| Working frequency | 2.400-2.4835 GHz; 5.125-5.25GHz; 5.650-5.755GHz; 5.725-5.850GHz |
| Effective Isotropic Radiated Power(EIRP) | 2.400-2.4835 GHz FCC: < 26 dBm SRRC/CE/MIC: < 20 dBm 5.125-5.25GHz FCC/SRRC: < 26dBm 5.650-5.755GHz MIC: < 20 dBm 5.725-5.850GHz SRRC/FCC: < 26 dBm;CE: < 14 dBm SRRC/CE/MIC: < 20 dBm |

| | |
|------------------------|--|
| Communication distance | Base station and aircraft: 30km(FCC) Base station and ground station: 200m (FCC) (no interference, no blockage;the base station erection height, namely the height from the antenna to the tail end of the tripod, is 2m, the height difference with the ground station is within 10m, and the height of the ground station from the ground is 1.2m). |
|------------------------|--|

| Electric features of base station | |
|--|--|
| Power consumption | 7.5W |
| Power supply | 5-20V DC |
| Battery | Battery Type: lithium polymer battery Capacity: 4950 mAh Energy: 57.1 WH |
| Working time | >7.5h |

| Physical features of base station | |
|--|---------------------|
| Physical features of base station | 193 mm×177 mm×73 mm |
| Weight | 1275g |
| Dustproof and waterproof | IP64 |
| Operating ambient temperature | -20° C to 50° C |