Installation and User Guide

Elara™ DX-Series Camera



© 2023 Teledyne FLIR LLC All rights reserved worldwide. No parts of this manual, in whole or in part, may be copied, photocopied, translated, or transmitted to any electronic medium or machine readable form without the prior written permission of Teledyne FLIR LLC.

Names and marks appearing on the products herein are either registered trademarks or trademarks of Teledyne FLIR LLC and/or its subsidiaries. All other trademarks, trade names, or company names referenced herein are used for identification only and are the property of their respective owners.

This product is protected by patents, design patents, patents pending, or design patents pending.

Photographs and images appearing in this manual may have been modified for illustrative purposes using commercial image editing software and may not always reflect an actual product configuration.

The contents of this document are subject to change without notice.

For additional information visit www.flir.com or write to Teledyne FLIR LLC

Teledyne FLIR LLC
6769 Hollister Avenue
Goleta, CA 93117

Support: <https://support.flir.com/>

Important Instructions and Notices to the User:

This device complies with part 15 of the FCC Rules. Operation is subject to the following two conditions: (1) This device may not cause harmful interference, and (2) this device must accept any interference received, including interference that may cause undesired operation.

Modification of this device without the express authorization of Teledyne FLIR LLC may void the user's authority under FCC rules to operate this device.

Note 1: This equipment has been tested and found to comply with the limits for a Class A digital device, pursuant to part 15 of the FCC Rules. These limits are designed to provide reasonable protection against harmful interference when the equipment is operated in a commercial environment. This equipment generates, uses, and can radiate radio frequency energy and, if not installed and used in accordance with the instruction manual, may cause harmful interference to radio communications. Operation of this equipment in a residential area is likely to cause harmful interference in which case the user will be required to correct the interference at the user's own expense.

Note 2: If this equipment came with shielded cables, it was tested for compliance with the FCC limits for a Class A digital device using shielded cables and therefore shielded cables must be used with the device.

Industry Canada Notice:

This Class A digital apparatus complies with Canadian ICES-003.

Avis d'Industrie Canada:

Cet appareil numérique de la classe A est conforme à la norme NMB-003 du Canada.

Proper Disposal of Electrical and Electronic Equipment (EEE)



The European Union (EU) has enacted Waste Electrical and Electronic Equipment Directive 2012/19/EU (WEEE), which aims to prevent EEE waste from arising; to encourage reuse, recycling, and recovery of EEE waste; and to promote environmental responsibility.

In accordance with these regulations, all EEE products labeled with the "crossed out wheeled bin" either on the product itself or in the product literature must not be disposed of in regular rubbish bins, mixed with regular household or other commercial waste, or by other regular municipal waste collection means. Instead, and in order to prevent possible harm to the environment or human health, all EEE products (including any cables that came with the product) should be responsibly discarded or recycled.

To identify a responsible disposal method nearby, please contact the local waste collection or recycling service, the original place of purchase or product supplier, or the responsible government authority in the area. Business users should contact their supplier or refer to their

Document History

Revision	Date	Comment
100	September 2020	Initial Teledyne FLIR release
110	May 2021	Added pendant cap thread specification
120	February 2023	New DX-606z model; added geotracking, expanded thermal sensor settings, alarms, SNMP

Product Registration and Warranty Information

Register the product at <https://customer.flir.com>.

For warranty information, see <https://www.flir.com/support-center/warranty/security/flir-security-product-warranties/>.

Table of Contents

- 1. Camera Overview 1**
 - 1.1 Accessing Product Information from the Teledyne FLIR Website 2
 - 1.2 Camera Dimensions 3
 - 1.3 Camera Specifications 4
- 2. Installation 7**
 - 2.1 Supplied Components 7
 - 2.2 Site Preparation 8
 - 2.3 Supplying Power to the Camera 8
 - 2.4 Connect the Camera 10
 - 2.5 Configure for Networking 11
 - 2.6 Secure the Camera 13
 - 2.7 Waterproof the Camera 14
 - 2.8 Fit Mounting Hardware 14
 - 2.9 Connect and Attach the Camera 14
 - 2.10 Install and Test the Optional Wash Kit 15
 - 2.11 Additional Configuration 17
 - 2.12 Attach the Camera to a Supported VMS 18
- 3. Operation 19**
 - 3.1 Accessing the Camera 19
 - 3.2 View Settings Home Page 19
 - 3.3 Making Changes to Settings 21
 - 3.4 Video Page 22
 - 3.5 Visible Page 24
 - 3.6 Thermal Page 27
 - 3.7 Input/Output (I/O) Page 31
 - 3.8 PTZ Page 32
 - 3.9 Illumination Page 35
 - 3.10 OSD Page 35
 - 3.11 Wiper Page 36
 - 3.12 Georeference Page 37
- 4. Configuration 40**
 - 4.1 Network Page 40
 - 4.1.1 Settings 40
 - 4.1.2 SNMP 41
 - 4.2 Date & Time Page 42
 - 4.3 Users Page 43

Table of Contents

- 4.4 Cloud Page 44
- 4.5 Alarm Page 44
 - 4.5.1 Modifying or Defining Rule Triggers 45
 - 4.5.2 Modifying or Defining Rule Actions 46
- 4.6 Audio Page 47
- 4.7 I/O Devices Page 48
- 4.8 Messaging Page 49
- 4.9 Cyber Page 50
 - 4.9.1 Certificates 50
 - 4.9.2 802.1x 51
 - 4.9.3 TLS/HTTPS 52
 - 4.9.4 Services 52
 - 4.9.5 IP Filter 53
- 4.10 ONVIF Page 53
- 4.11 Map Page 54
- 4.12 Geotracking Page 56
- 4.13 Firmware & Info Page 57
- 5. Maintenance and Troubleshooting Tips 59**
 - 5.1 Cleaning 59
 - 5.2 Troubleshooting 59
- 6. Appendices 61**
 - 6.1 Mounting Accessories 61
 - 6.2 Creating a DEM File 64

1 Camera Overview

Elara DX-Series cameras include a thermal sensor with digital zoom; a 4K visible light camera with 31x optical zoom; audio; digital I/O; near-infrared (NIR) illumination; laser focus technology (LiDAR); a camera lens window wiper (wash kit available as an optional accessory); and automatic side heat sensors. The DX-606z model features a lens for the thermal sensor with 5x motorized and continuous optical zoom. The camera streams video over IP, using MJPEG or H.264 encoding.

When connected to an IP network, the camera functions as a server. It provides services such as camera control, video streaming, and network communications using an open, standards-based protocol. You can use Teledyne FLIR and third-party video management system (VMS) clients, including systems that are compatible with ONVIF®, to control the camera and stream video during day-to-day operations. For a list of supported VMS clients, refer to the camera's web page on [the Teledyne FLIR website](http://www.flir.com) (www.flir.com).

For installation help, contact your local Teledyne FLIR service representative or use [the product's web page on the Teledyne FLIR website](http://www.flir.com) to contact Support. All installers and integrators are encouraged to take advantage of the training offered by Teledyne FLIR; visit <https://www.flir.com/support-center/training/> for more information.

For safety, and to achieve the highest levels of performance from the camera system, always follow the warnings and cautions in this manual when handling and operating the camera.

CLASS 1 LASER PRODUCT

These cameras are Class 1 Laser Products that comply with IEC 60825-1:2014.



Caution

Use of controls or adjustments or performance of procedures other than those specified herein may result in hazardous radiation exposure.

Attention

L'utilisation des commandes ou réglages ou l'exécution des procédures autres que celles spécifiées dans les présents exigences peuvent être la cause d'une exposition à un rayonnement dangereux.



Warning

Before drilling into surfaces for camera mounting, verify that electrical or other utility service lines are not present. Serious injury or death may result from failure to heed this warning.



Caution

Except as described in this manual, do not open the camera for any reason. Damage to the camera can occur as the result of careless handling or electrostatic discharge (ESD). Always handle the camera with care to avoid damage to electrostatic-sensitive components.

Prior to making any connections, ensure the power supply or circuit breaker is switched off.

Be careful not to leave fingerprints on the camera's infrared optics.

Operating the camera outside of the specified input voltage range or the specified operating temperature range can cause permanent damage.

Related Documentation

- *Elara DX-Series Quick Install Guide*
- *Teledyne FLIR CGI Interface Description 2.1*
- *Nexus CGI WebSockets Manual*
- *Teledyne FLIR Sensors SDK Programmer's Guide*

1.1 Accessing Product Information from the Teledyne FLIR Website

Up-to-date resources for the camera, including the Discovery Network Assistant (DNA) software tool and this installation and user guide, are available from the camera's product details and support pages on [the Teledyne FLIR website](https://www.flir.com).

To access product information from the Teledyne FLIR website:

1. Open <https://www.flir.com/browse/security/> and navigate to [Products > Security > Thermal Security Cameras](#).
2. Find and click FLIR Elara DX-Series. The product details page appears.

MULTISPECTRAL PTZ THERMAL CAMERA

FLIR Elara DX-Series

MODEL: DX-650, 640 X 480, 50° FOV

Go to Product Support [Open the product's support page](#)

The FLIR Elara™ DX-Series multispectral pan/tilt/zoom (PTZ) security camera provides full situational awareness in the most punishing environments. Combining thermal and visible light imagers, the Elara DX-Series gives operators the ability to monitor large areas in complete darkness, glaring light, and adverse weather. The exceptional detection and identification capabilities of multispectral cameras help integrators provide solutions for challenging imaging problems at critical infrastructure sites and remote facilities.

PRODUCT VARIATIONS:
DX-650, 640 X 480, 50° FOV

[REQUEST INFO](#) [REQUEST QUOTE](#)

MULTISPECTRAL IMAGING IN ANY CONDITION
Integrated thermal and visible sensors capture sharp video where other PTZ cameras cannot.

DESIGNED TO WITHSTAND EXTREME ENVIRONMENTS
Built to handle the challenges of critical infrastructure sites and other demanding locations.

SUPERIOR MONITORING OF LARGE AREAS AND CHANGING ENVIRONMENTS
PTZ capability gives operators continuous visibility in large areas

SPECIFICATIONS

OVERVIEW	
Detector Type	Long-Life, Uncooled VOx Microbolometer
Focal Length	Visible: 6.5mm - 202mm
Focus Range	Athermalized, Focus-Free
Optical Characteristics	FOV: 50° x 38° Focal Length: 8.7 mm
Pixel Pitch	12 μm

Product Details Page

To see the camera's specifications and related content, scroll down.

3. Click **Go to Product Support**. The product support page appears.
4. Download product documentation from the Documents tab.

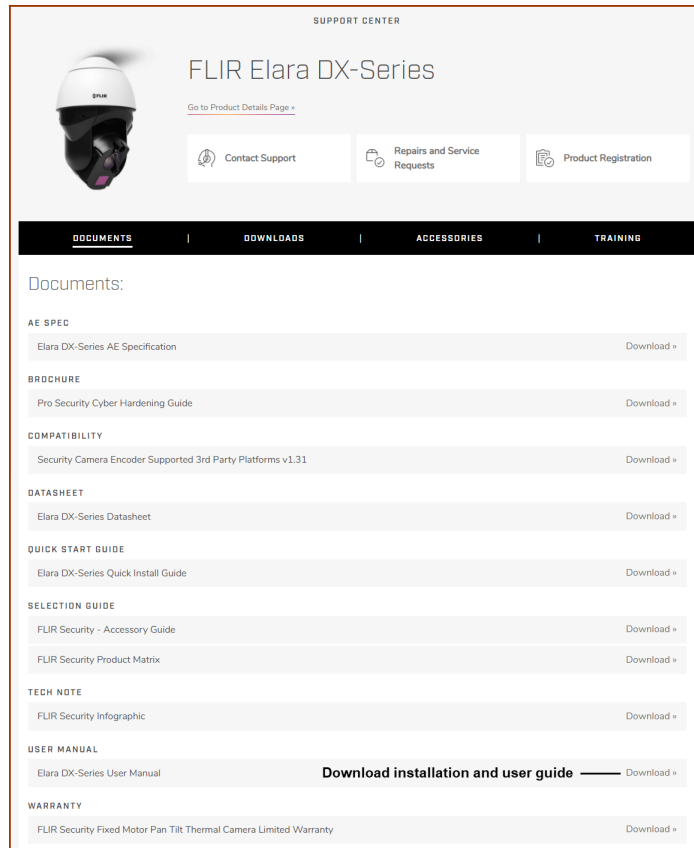

Product Support Page - Documents Tab

5. Download the DNA tool from the Downloads tab.

1.2 Camera Dimensions

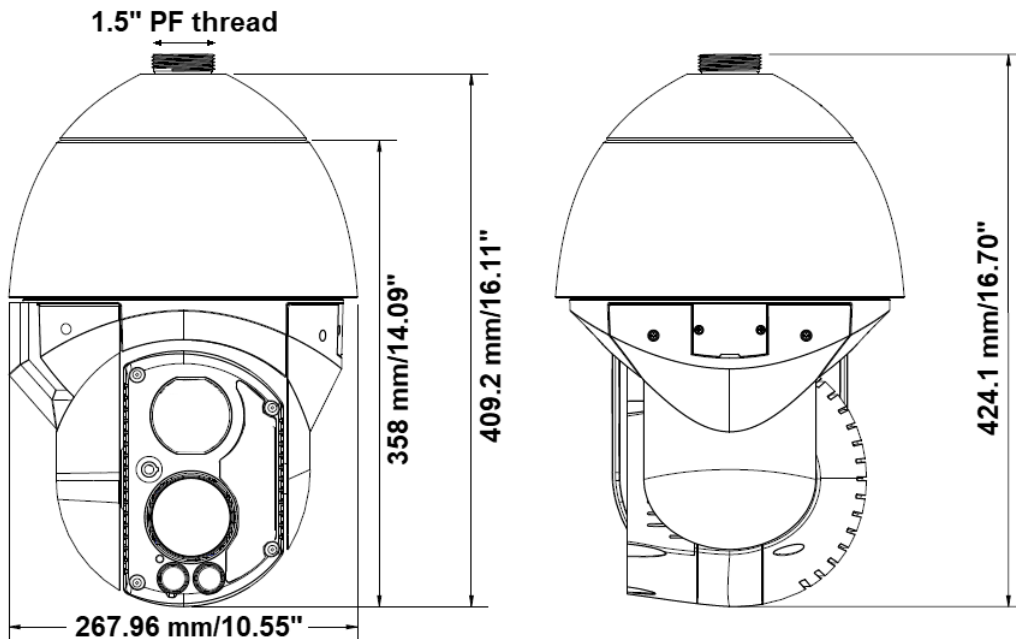

1.3 Camera Specifications

Thermal Sensor & Optics	Array Format	DX-3XX models: 320x256 DX-6XX models: 640x512			
	Sensitivity	< 50mK @ 25°C			
	Sensor Technology	Long-Life, Uncooled VOx Microbolometer			
	Pixel Pitch	12 µm			
	Frame Rate	NTSC: 30 Hz or PAL 25 Hz / 8.3 Hz available			
	Optical Characteristics	Model	Thermal FOV	Focal Length	
		DX-350	50° × 38°	4.3 mm	
		DX-324	24° × 18°	9.1 mm	
		DX-312	12° × 9°	18 mm	
		DX-306	6° × 5°	36 mm	
		DX-650	50° × 38°	8.7 mm	
		DX-624	24° × 18°	18 mm	
		DX-612	12° × 9°	36 mm	
		DX-608	8° × 6°	55 mm	
DX-606z	29.9°-5.8° HFoV	Zoom 15-75 mm			
F/#	F1.0 DX-606z: F1.2				
Zoom	Continuous E-Zoom up to 4x DX-606z: Continuous optical zoom up to 5x				
Spectral Range	7.5 µm to 13.5 µm				
Focus Range	Athermalized, Focus-Free				
Video	Video Compression	Thermal: One channel of H.264 & MJPEG Visible: Two independent channels of H.264 & MJPEG			
	Streaming Resolution	Thermal: 640x512 @ 30fps max Visible: Up to 1080p on each stream at 30 FPS each. One 4K stream at 30 FPS, or one 4K stream at 15 FPS and second stream in 1080p at 30 FPS.			
	Thermal Image Settings	Auto AGC, Digital Detail Enhancement (DDE), Brightness, Sharpness, Contrast			
	Thermal AGC Region of Interest (ROI)	Default, presets and user-definable to ensure optimal image quality on subjects of interest			
	Image Uniformity Optimization	Automatic Flat-Field Correction (FFC) - Thermal and Temporal Triggers, and manual FFC			
System Integration	Ethernet	10/100/1000 Mbps			
	Network APIs	FLIR SDK; FLIR CGI; ONVIF Profile S			
	Digital I/O	Input: Four sets / 5V 10kΩ pull up Output: Two sets / relay output, 130mA max at 24 VDC / 24 VAC			
	Audio I/O	Bi-directional via terminal block connection			

	Illumination	Up to 200m NIR illumination Distance: Up to 200m (656ft.) 6° / 30 / 90° Peak emission wavelength: 850 nm
	Lens Window Wiper	Wiper is standard and camera is compatible with a wash kit accessory
Network	Supported Protocols	IPv4, HTTP, UPnP, DNS, NTP, RTSP, RTP, TCP, UDP, ICMP, IGMP, DHCP, ARP
Pan / Tilt Performance	Pan Angle / Speed	Continuous 360° - 0.1° to 90°/sec
	Tilt Angle / Speed	-10° to 190° - 0.1° to 60°/sec
	Programmable Presets	256
	Preset Accuracy	0.25°
	Sequence & Pattern	8 each
	Mechanical Flip	Enable / disable
General	Input Voltage	24 VAC (±10%) Universal Power over Ethernet (PoE) 60W 4 pair forced mode, no support for CDP/LLDP
	Weight	9.12 kg (20.1lb)
	Dimensions	Diameter: 275mm (10.8in) Height: 368mm (14.5in)
Environmental	IP Rating (Dust & Water Ingress)	IP66
	Operating Temperature Range	-40°C to 60°C
	Storage Temperature Range	-55°C to 85°C
	Humidity	0-95% relative
	Shock	IEC 60068-2-27
	Vibe	IEC 60068-2-64
	Vandalism	IK10 except for windows
Compliance & Certifications	FCC Part 15 (Subpart B, class A); CE Marked; RoHS; WEEE (Waste Electrical and Electronic Equipment Directive), NEMA 4X, ONVIF Profile S, IEC 62368	
Visible Light Camera	Sensor Type	4K UHD 1/1.8" Progressive CMOS
	Lens Field of View	HFOV: 61.8° - 2.15° VFOV: 36.65° - 1.2°
	Focal Length	6.5mm - 202mm
	Zoom	Optical Zoom: up to 31x Digital Zoom: E-Zoom up to 8x
	F/#	F1.55 (Wide); F4.8 (Tele)
	Sensitivity	Color: 0.25 Lux (@ F1.6 AGC On, 30 FPS) B/W: 0.10 Lux (@ F1.6 AGC On, 30 FPS)

Cyber Security	IEEE 802.1X TLS/HTTPS User authentication Access control via firewall User credentials with policy enforcement Digest authentication
-----------------------	---

Specifications are subject to change without notice. For the most up-to-date specs, go to [the Teledyne FLIR website](#).

2 Installation

This chapter includes information about:

- [Supplied Components](#)
- [Site Preparation](#)
- [Supplying Power to the Camera](#)

To install the camera, Teledyne FLIR recommends connecting the camera on a bench or in a lab and configuring it for networking before mounting and aiming it:

1. [Connect the Camera](#)
2. [Configure for Networking](#)
3. [Fit Mounting Hardware](#)
4. [Secure the Camera](#)
5. [Waterproof the Camera](#)
6. [Connect and Attach the Camera](#)
7. [Install and Test the Optional Wash Kit](#)
8. [Additional Configuration](#)
9. [Attach the Camera to a Supported VMS](#)

However, circumstances can dictate adjusting the sequence of the steps. For example, you can mount the camera before configuring it for networking, or connect the camera before mounting it.

2.1 Supplied Components

The Elara DX-Series camera kit includes these items:

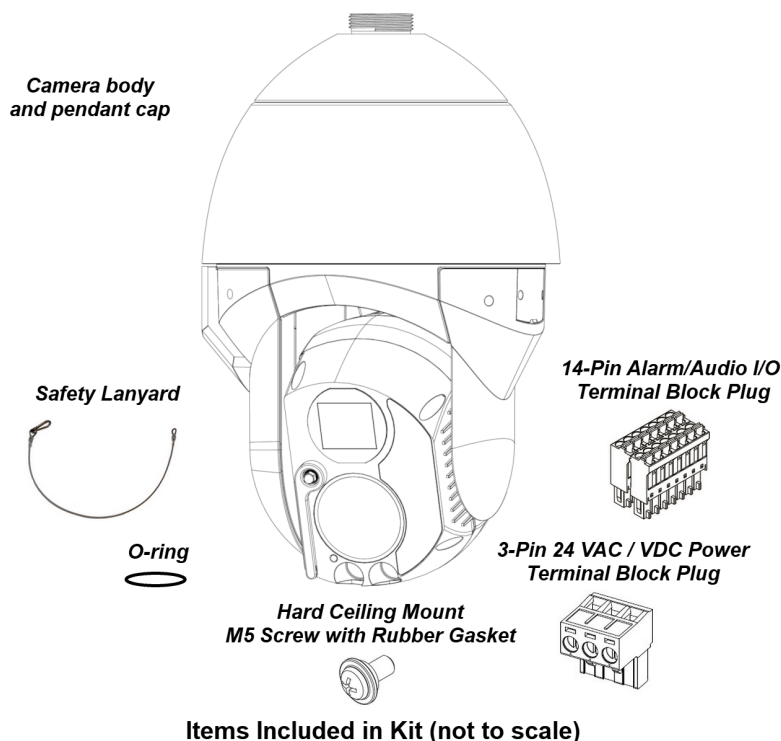

2.2 Site Preparation

This camera can be installed outdoors or indoors. There are several requirements that should be properly addressed prior to installation at the site.

The following specifications are requirements for proper installation and operation of the unit:

- **Ambient Environment Conditions:** Avoid positioning the unit near heaters or heating system outputs. Avoid exposure to direct sunlight. Use proper maintenance to ensure that the unit is free from dust, dirt, smoke, particles, chemicals, smoke, water or water condensation, and exposure to EMI.
- **Accessibility:** The location used should allow easy access to unit connections and cables.
- **Safety:** Cables and electrical cords should be routed in a manner that prevents safety hazards, such as from tripping, wire fraying, overheating, etc. Ensure that nothing rests on the unit's cables or power cords.
- **Ample Air Circulation:** Leave enough space around the unit to allow free air circulation.
- **Cabling Considerations:** Units should be placed in locations that are optimal for the type of video cabling used between the unit and the cameras and external devices. Using a cable longer than the manufacturer's specifications for optimal video signal may result in degradation of color and video parameters.
- **Physical Security:** The unit provides threat detection for physical security systems. In order to ensure that the unit cannot be disabled or tampered with, the system should be installed with security measures regarding physical access by trusted and un-trusted parties.
- **Network Security:** The unit transmits over IP to security personnel for video surveillance. Proper network security measures should be in place to assure networks remain operating and free from malicious interference. Install the unit on the backbone of a trusted network.
- **Electrostatic Safeguards:** The unit and other equipment connected to it (relay outputs, alarm inputs, racks, carpeting, etc.) shall be properly grounded to prevent electrostatic discharge.

For outdoor installation, Teledyne FLIR recommends:

- Always using weatherproof equipment, such as boxes, receptacles, connectors, etc.
- For electrical wiring, using the properly rated sheathed cables for conditions to which the cable will be exposed (for example, moisture, heat, UV, physical requirements, etc.).
- Planning ahead to determine where to install infrastructure weatherproof equipment. Whenever possible, ground components to an outdoor ground.
- Using best security practices to design and maintain secured camera access, communications infrastructure, tamper-proof outdoor boxes, etc.

The physical installation of the unit is the first phase of making the unit operational in a security plan. The goal is to physically place the unit, connect it to other devices in the system, and to establish network connectivity. When finished with the physical installation, complete the second phase of installation, which is the setup and configuration of the unit.

2.3 Supplying Power to the Camera

The camera can be powered by PoE or by a 24 VAC external power supply (not included in the camera kit). If using PoE, make sure the PoE switch or injector is a Power Sourcing Equipment (PSE) device.

- If using a PoE-capable network switch, the switch needs to support Universal PoE 60W 4 pair forced mode. For information regarding recommended switches, contact Teledyne FLIR Support. **Note:** The camera does not support CDP / LLDP.

- If using a PoE injector, use a Teledyne FLIR CP-POE-4P-60W-xx injector or contact Teledyne FLIR Support for information about compatible injectors.
- If using an external AC power supply, connect the power supply's wires to the power terminal block.

 **Warnings**

- All electrical work must be performed in accordance with local regulatory requirements.
- Use a UL Listed Power Adapter that meets LPS (Limited Power Source) requirements.
- Note the camera's maximum power consumption:

		LED	-40°C	25°C	60°C	
24 VAC (W)	Camera static	Off	N/A	21	21	
		On	27	43	43	
	PTZ motion	Off	N/A	29	26	
		On	57	50	49	
	Maximum, including wiper and IRCUT			61	52	52
PoE (W)	Camera static	LED	-40°C	25°C	60°C	
		Off	N/A	15	15	
	On	35	32	32		
	PTZ motion	Off	N/A	22	19	
		On	41	37	39	
	Maximum, including wiper and IRCUT			43	39	42

- A PoE injector should be connected only to a PoE network inside a building and not routed outside the building.
- If the camera is installed outdoors with an external power supply, the power supply must be installed with proper weatherproofing.
- A qualified service person should install the camera.

2.4 Connect the Camera

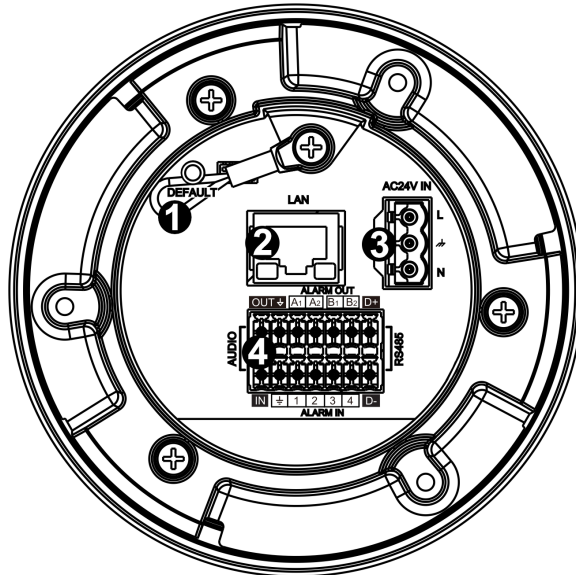

Connectors

Connector	Connection
1 DEFAULT	To reset factory defaults at any time, press the Default button for at least 20 seconds.
2 LAN	Attach a Cat 5e or Cat 6 cable from the network switch to the RJ45 LAN connector for a 10/100/1000 Mbps Ethernet and PoE connection. For information about using PoE, see Supplying Power to the Camera . Verify that the LAN connector LEDs are steady green and flashing yellow.
3 AC24V IN	If using a 24 VAC power supply, connect its wires to the three-pin power terminal block. See pin assignment below.
4 14-pin terminal block	Attach wires from external devices to the 14-pin terminal block connector for alarm and audio in/out (see diagram and definitions below).

3-Pin Power Terminal Block	Pin	24 VAC
	1	L (Live; white; positive)
	2	Ground (Earth)
	3	N (Neutral; black; negative)

14-Pin Terminal Block	Pin	Definition	Pin	Definition
	1	Audio-Out	8	Not used
	2	Ground (Audio I/O)	9	Alarm-In 4
	3	Alarm-Out A1	10	Alarm-In 3
	4	Alarm-Out A2	11	Alarm-In 2
	5	Alarm-Out B1	12	Alarm-In 1
	6	Alarm-Out B2	13	Ground (Alarm I/O)
	7	Not used	14	Audio-In

Warning

This product contains a battery that is soldered to the PCB. There is a risk of explosion if the battery is replaced by an incorrect type. **Do not replace the battery.** The battery should be disposed of in accordance with the battery manufacturer's instructions.

2.5 Configure for Networking

You can discover and configure the camera for networking using the Discovery Network Assistant (DNA) software tool; the camera's web page; or a supported VMS. Using the DNA tool or the camera's web page requires using the default admin user or any user assigned the admin or expert role.

Task	DNA Tool	Camera's Web Page
Discover camera IP address	•	
Configure IP address, mask, and gateway	•	•
Configure DNS settings, MTU, and Ethernet speed		•
Change user credentials	•	•
Configure IP address, mask, and gateway for more than one camera at the same time	•	

Notes

- Teledyne FLIR recommends using the DNA tool to discover the camera on the network. It does not require a license to use and is a free download from [the product's web page on the Teledyne FLIR website](#). For more information about using DNA, including how to configure more than one camera at the same time, see the *DNA User Guide*. While the software is open, click the Help icon .
- For more information about using a supported VMS to configure one or more cameras at the same time, see the VMS documentation.

By default, DHCP is enabled on the camera and a DHCP server on the network assigns the camera an IP address. If the camera cannot connect to a DHCP server, the camera's default IP address is 192.168.0.250.

- If the camera is managed by FLIR Horizon or Meridian VMS and the VMS is configured as a DHCP server, the VMS automatically assigns the camera an IP address.
- If the camera is managed by FLIR Latitude VMS or is on a network with static IP addressing, you can manually specify the camera's IP address using the DNA tool or the camera's web page.

To configure the camera for networking using the DNA tool:

1. Make sure the camera and the PC are on the same LAN segment.
2. Run the DNA tool (DNA.exe) by double-clicking . The Discover List appears, showing compatible devices on the VLAN and their current IP addresses.
3. In the DNA Discover List, verify that the camera's status is *Online*.

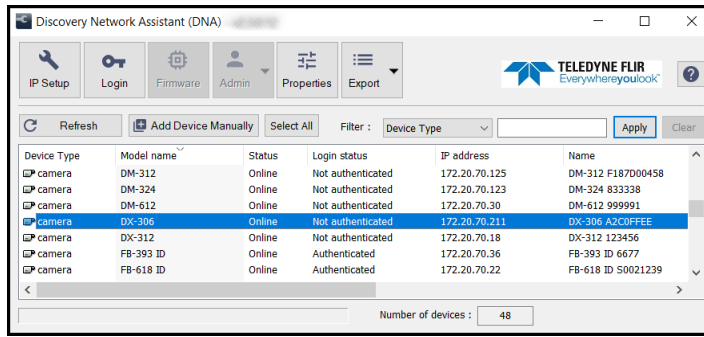

If this is the first time you are configuring the camera or if it is the first time after resetting the camera to its factory defaults, DNA automatically authenticates the camera with the default password for the camera's admin user (*admin*).

If the admin user password has been changed, you need to authenticate the camera.

In the DNA Discover List, right-click the camera and select **Login**.

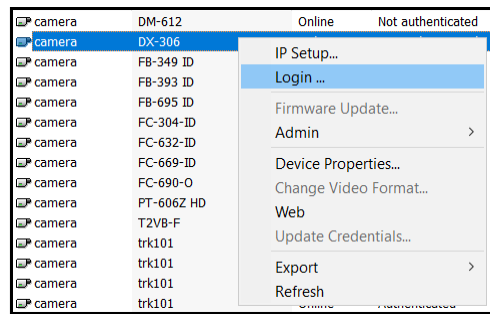

In the **DNA - Login** window, type the password for the admin user. If you do not know the admin user password, contact the person who configured the camera's users and passwords.

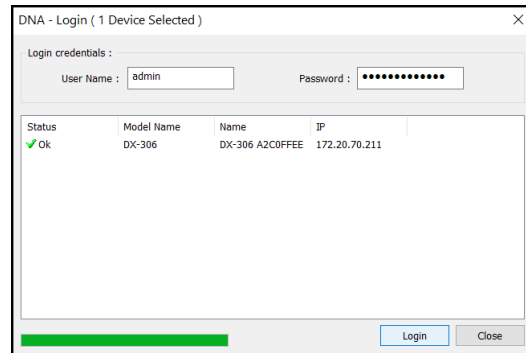

Click **Login**, wait for ✓ Ok status to appear, and then click **Close**.

4. In the DNA Discover List, verify that the camera's status is *Authenticated*.

5. Change the camera's IP address.

Right-click the camera and select **IP Setup**.

In the **DNA - IP Setup** window, clear *Use DHCP* and specify the camera's *IP address*. You can also specify the *Mask* (default: 255.255.255.0) and *Gateway*. Then, click **Update**, wait for ✓ Ok status to appear, and then click **Close**.

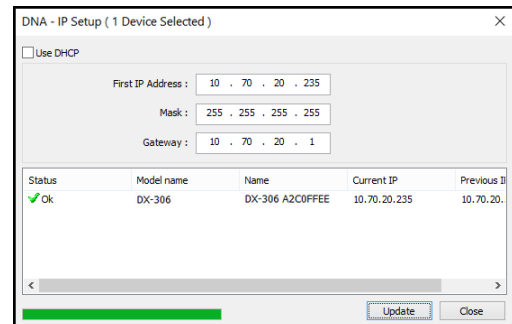

To manually specify the camera's IP address using the camera's web page:

1. [Access the camera's web page](#).

2. On the [View Settings Home Page](#), click **System Settings**, and make sure the [Network > Settings page](#) appears.
4. Click **Static** IP addressing and then manually specify the camera's *Hostname*, *IP address*, *Netmask*, and *Gateway*.

You can also specify the *DNS Mode*, *Name Servers*, *MTU* (maximum transmission unit), and *Ethernet Speed*.
5. Click **Save**. Applying any changes on the Network page requires reboot the camera.

2.6 Secure the Camera

To prevent the camera from falling, you need to secure it using a safety lanyard.

1. Before attaching the mounting accessory to the mounting surface, attach the safety lanyard to a secure anchor point on the mounting surface or on the accessory.
 1. Attach the lanyard to the safety ring on the camera.
 2. Route the power, Ethernet, and other cables through the mounting accessory and attach the mounting accessory to the mounting surface.
 3. Route the power, Ethernet, and other cables through the pendant cap and attach the pendant cap to the mounting accessory.
 4. Connect the cables to the camera.
 5. Carefully insert the camera into the pendant cap and rotate the camera until it locks into place (1/3 turn).

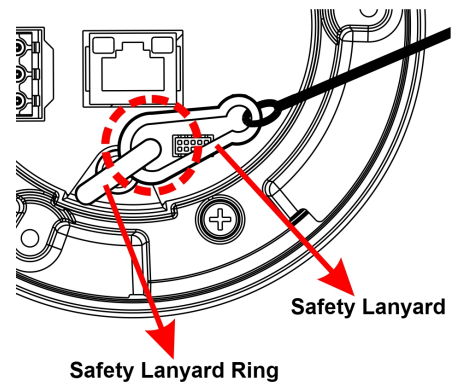

Warning

The metal locking mechanism carries the weight of the camera. If the camera is not locked into place, it could become loose and fall.

The screw that attaches the pendant cap to the camera needs to line up with one of the corresponding screw holes on the camera.



Pendant Cap Screw

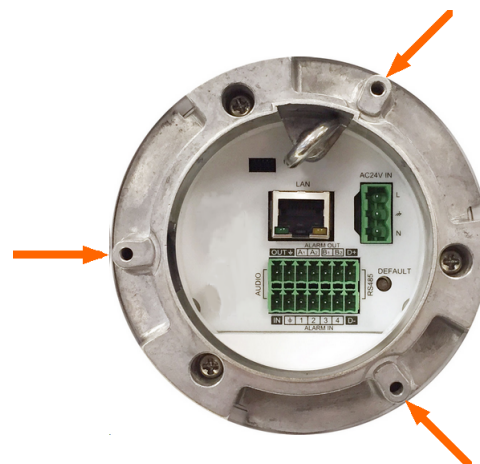

Pendant Cap Screw Holes on Camera

1. Securely tighten the pendant cap screw into the camera. The screw prevents the camera from rotating.
2. Try to rotate the camera and make sure it is not possible to rotate the camera.

Warning

If the camera can be rotated, it could become loose and fall.

2.7 Waterproof the Camera

The camera is IP66-rated to prevent water from entering the camera. Nevertheless, water can enter the camera if it is not installed properly. Please make sure the warnings below are strictly followed when installing the camera.

1. Place all cables and the adaptor in dry and well-waterproofed environments, e.g. waterproof boxes. This prevents moisture accumulation inside the camera and moisture penetration into cables.

2. Seal the cable entry hole of the pendant cap with the rubber O-ring (supplied with the camera) and use thread seal tape to keep water from entering the camera.

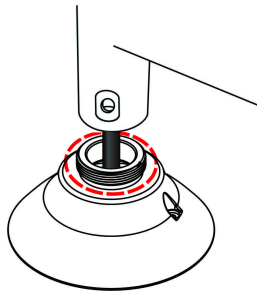

Waterproofing the Pendant Cap

3. While running cables, slightly bend the cables in a U-shaped curve to create a low point. This prevents water from entering the camera along the cables from above.

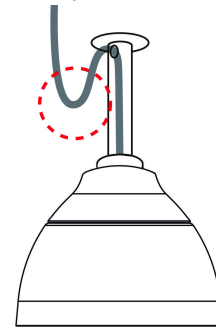
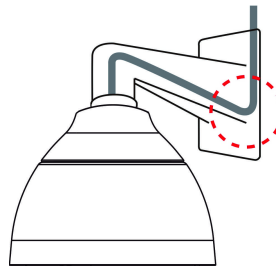

U-Shaped Cable Installation

2.8 Fit Mounting Hardware

Install the mounting hardware for the camera according to the instructions for the hardware.

For the list of mounting accessories available from Teledyne FLIR for installing your camera, see [Mounting Accessories](#).

Important

Regardless of how you mount the camera, it needs to be horizontally mounted to ensure that it pans parallel to the horizon.

2.9 Connect and Attach the Camera

Using the information in [Connect the Camera](#), connect the cables to the camera.

Then, according to the installation instructions for the mounting hardware, attach the camera to the mounting hardware.

2.10 Install and Test the Optional Wash Kit

As an optional accessory, Teledyne FLIR recommends the Videotec line of wash kits for PTZ cameras, including the WASPT0V5L5M00 washer pump, five-liter tank, five-meter delivery kit. For general information about installing a Videotec wash kit, see the kit's instructions manual.

This section and this guide contain important information about installing the washer and using it specifically with the DX-Series camera.

Connection of the board

Connect the following:

J9 terminal on the washer pump control board		Camera's 14-pin terminal connector
CP pump activation (dry contact)	➔	Alarm-Out A1 pin (3)
GCP GND pump activation (dry contact)	➔	Alarm-Out A2 pin (4)

Pump installation

Caution

DX-608 camera model: Do not use antifreeze liquid in the washer tank. This camera model does not have a silicon window protecting its germanium thermal camera lens. Using antifreeze liquid causes irreparable damage to the germanium lens. In this case, add ethanol in a 20% solution.

Washer installation (DX-Series)

1. Cut the cables to size and either restore or make the connections to the positioning unit.

2. Shorten the semi-rigid washer pipe (01) as needed. Unscrew the nut (02) from the joint and slide it along the pipe. Insert the end of the pipe into the ogive (03).

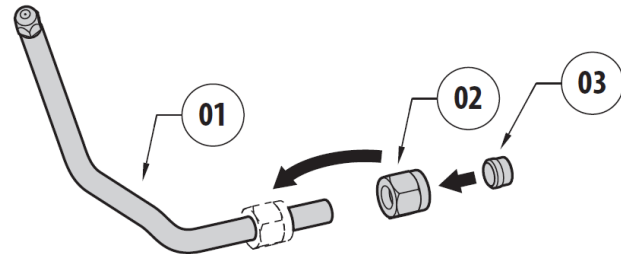

3. Lock the nut to the coupling.

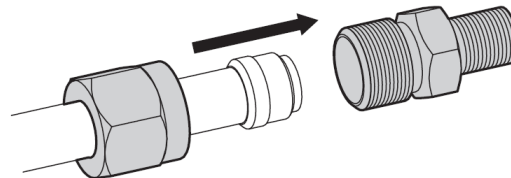

4. Tighten the delivery joint.

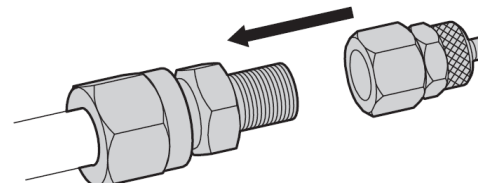

5. Unscrew the knurled nut (01) from the delivery joint (02). Insert the knurled nut on the delivery pipe (03). Insert the end of the delivery pipe into the spinner (04). Lock the nut to the coupling.

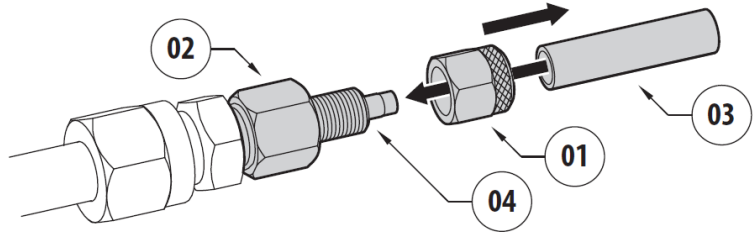

6. Fasten the semi-rigid pipe and aim the nozzle towards the camera lens windows. Depending on how and where you are installing the camera and the wash kit, you can use one of the nozzle support brackets supplied with the wash kit to secure and aim the nozzle.

! Important

When you test the wash kit, you will set the camera's washer position using the camera's web page. Aim the washer nozzle so that it sprays liquid over both camera lens windows when the camera is in what will be its washer position. Activating the camera's wiper when the lens windows are dry causes irreparable damage to the window coatings and voids the camera's warranty.

Make sure the camera's I/O settings activate the washer pump

1. With a user assigned the admin or expert role, log in the camera's web page. For information about how to log in to the camera's web page, see [Accessing the Camera](#).
2. Open the [I/O Devices Page](#).
3. Select local output 1.
4. Make sure the following local output 1 default settings are specified:

Setting	Value
State	Off
Idle State	Open
Reset Interval	0 seconds (automatic output pin reset is disabled)

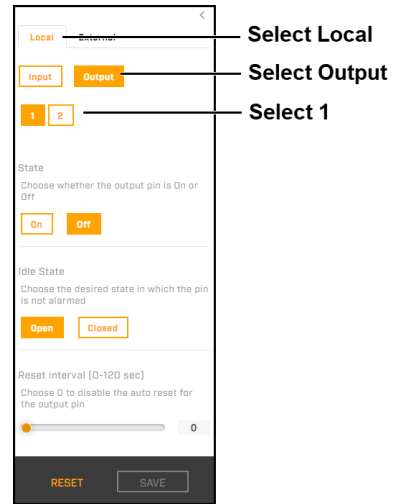

Testing the washer and wiper

Before testing the washer and wiper, make sure you:

- Install the wash kit according to the kit's instructions manual and according to the instructions above.
- Fill the washer liquid tank.

1. Using the camera's web page, open the Wiper page.
2. Under **Washer device installed**, click **On**. To apply the change to this setting, the camera needs to reboot. After the camera reboots, log back in and open the Wiper page.

2. Set the washer position.

Click **Advanced Settings**.

Under **Washer Position**, use the PTZ controls to move the camera into a position so that the washer sprays liquid over both camera lens windows.

Click **Set**. The camera saves its current pan and tilt position as the washer position.

You can also specify a wash spray duration between 0-10 seconds.

3. Activate the washer.

Under **Washer**, click **Start**. Make sure the washer activates.

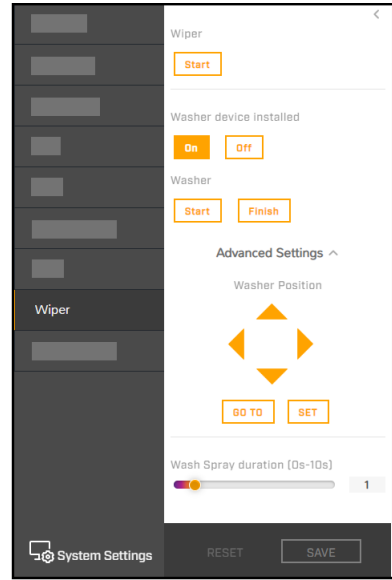

Important

If the initial washer position does not spray liquid over both camera lens windows, reset the washer position and try again.

2. Activate the wiper.

Under **Wiper**, click **Start**. Make sure the wiper performs one full wiper cycle.

Caution

Before activating the wiper, make sure the lens windows are wet. Using the wiper when the windows are dry causes irreparable damage to the window coatings and voids the warranty.

2.11 Additional Configuration

Depending on how you are installing and using the camera, and the network and VMS to which it is connected, initial configuration can also consist of enabling, disabling, or configuring the following settings using the camera's web page:

Settings		User Role
<ul style="list-style-type: none"> Live video and video streams Visible imager Thermal imager Current and idle I/O states PTZ settings 	<ul style="list-style-type: none"> External IR illumination (when enabled) On-screen display (OSD) Wiper Georeference 	Any user
<ul style="list-style-type: none"> Additional networking settings Date and time Alarms Audio Enabling and configuring external I/O devices Messaging 	<ul style="list-style-type: none"> Cybersecurity ONVIF auxiliary commands and output actions Map Geotracking Firmware, factory defaults, external IR illumination, and other system settings 	Default admin user / user assigned the admin or expert role

Settings	User Role
Users, roles, and passwords	User assigned the admin role

Some of these configuration tasks can be performed before or after mounting the camera, but others can or should be performed only after mounting and connecting the camera.

2.12 Attach the Camera to a Supported VMS

After you have mounted the camera and discovered or defined its IP address, you can use VMS Discovery / Attach procedures to attach the camera to a supported VMS.

3 Operation

This chapter includes information about how to [access the camera](#) and how to operate it using the [View Settings Home Page](#).

3.1 Accessing the Camera

To operate the camera, you first need to access it. You can access the camera by either logging in to the camera's web page. The camera's web page supports Google Chrome® and other popular web browsers.

To log in to the camera's web page:

1. Do one of the following:

- In the Teledyne FLIR Discovery Network Assistant (DNA) tool, double-click the camera in the Discover List.

The DNA tool does not require a license to use and is a free download from [the product's web page on the Teledyne FLIR website](#). Download the DNA tool; unzip the file; and then double-click  to run the tool (DNA.exe). The Discover List appears, showing compatible devices on the VLAN.

- Type the camera's IP address in a browser's address bar (when the PC and the camera are on the same network). If you do not know the camera's IP address, you can use the DNA tool to discover it.

2. On the login screen, type a user name and the password.

When logging in to the camera for the first time or for the first time after resetting the camera to its factory defaults, type admin for the user name and for the password.

If you do not know the user name or password, contact the person who configured the camera's users and passwords.

3. When logging in to the camera for the first time or for the first time after resetting the camera to its factory defaults, specify a new password for the admin user and then log back in using the new password.

Use a strong password consisting of at least 12 characters and at least one uppercase letter, one lowercase letter, and one number.

Passwords can include the following special characters: |@#~!\$&<>+ _-.,*? = .

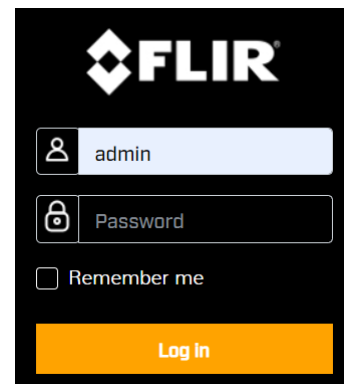

The camera's [View Settings Home Page](#) appears.

3.2 View Settings Home Page

The View Settings page displays live video images of the selected view. When a user assigned the expert or admin role logs in to the camera's web page, the page also displays View Settings menus along the left side banner and other options.

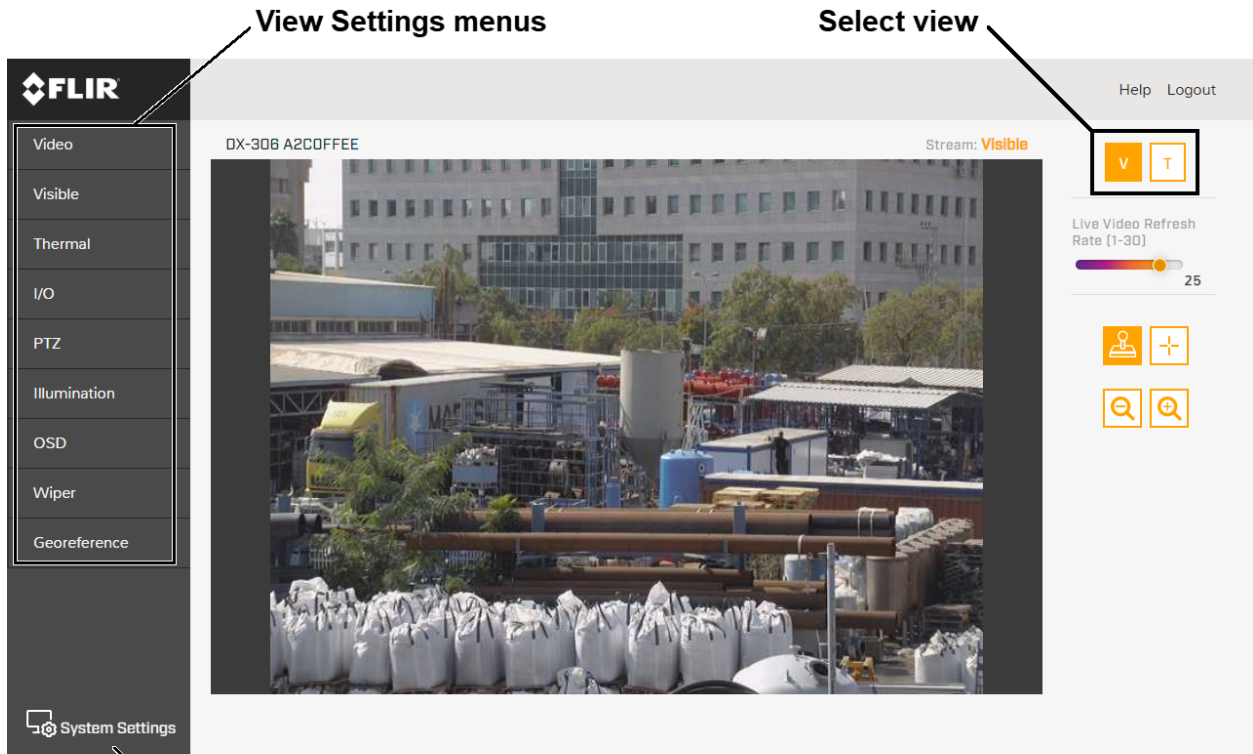

View Settings menus

Select view

System Settings



View Settings page for users assigned the admin or expert role

Live Video

You can select to view visible (V) or thermal (T) live video images. You can also set the Live Video Refresh Rate between 1-30 image frames per second (FPS). The view selected and the Live Video Refresh Rate setting only affect the live video; they do not affect the camera's video streams.

Pan, Tilt, and Zoom (PTZ)

You can toggle controlling the camera's pan and tilt between:

	<p>Emulated Joystick</p>	<p>When the mouse pointer is over live video, it becomes a directional arrow. To move the camera, you can:</p> <ul style="list-style-type: none"> • Click and release—Moves the camera once. • Click and hold—Moves the camera until it reaches its physical limit or you release. • Click and drag—Moves the camera as you drag the mouse.
	<p>Crosshairs</p>	<p>When the mouse pointer is over live video, it becomes a crosshairs. Clicking and releasing centers the camera on the crosshairs location.</p>

You can zoom in and out using:

- The onscreen buttons—Click once or click and hold for continuous zoom.
- The mouse wheel, when the mouse pointer is over live video.



Tips

- The zoom functions independently for each camera sensor. For example, zooming in when viewing thermal images does not affect visible images or video streams.
- Zooming in and out affects the video streams, unlike the Live Video Refresh Rate setting.

System Settings and Other Options

Users assigned the admin or expert role can click **System Settings** to configure the camera. For more information, see the [Configuration](#) chapter.

Additional choices are for Help and Logout.

3.3 Making Changes to Settings

The camera's configuration files store the following sets of settings:

- **Factory default settings**—The settings when you first connect the camera to power, and when resetting the camera to its factory default settings (see [Firmware & Info Page](#)). A partial factory reset restores all factory default settings except the settings on the [Network Page](#).
- **Saved settings**—The settings you save as you operate and configure the camera. When the camera reboots, it restores these settings. Changes made to any page since saving changes are lost.



Tip

Whenever possible, Teledyne FLIR recommends testing new settings before saving them because saving changes overwrites the previously saved settings.

View Settings

When you make a change to most View Settings, the **Reset** and **Save** buttons become enabled. For some View Settings, the camera immediately applies the changes, but does not save them; for example, on the [Visible Page](#) and on the [Thermal Page](#). For others, the camera does not apply changes until you save them.



Regardless of whether the camera has already applied changes, to save all changes since the last time these settings were saved, click **Save**. This can include earlier changes that were not saved.

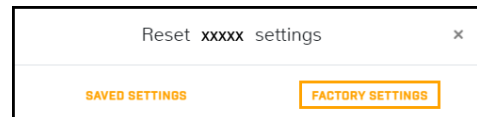

To restore previously saved settings or the factory default settings, click **Reset**. To close the message and return to the page without restoring settings, click the close icon ✕.



Tip

If you try to navigate to a different page before saving changes, a confirmation message appears. In most cases, you can click **Continue**, which allows you to navigate to other pages and test the setting changes. Then, you can return to the page and save the new settings. Or, you can discard the changes; save them; or close the confirmation message without discarding the changes or saving them by clicking the close icon ✕.

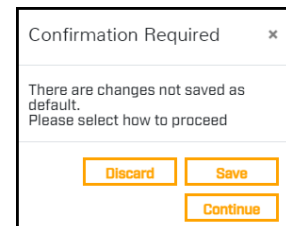

System Settings

When you make a change to most System Settings, the **Discard Changes** link and the **Save** button become enabled. For some System Settings, the camera immediately applies the changes, but does not save them; for example, on the [Audio Page](#). For others, the camera does not apply changes until you save them.



Regardless of whether the camera has already applied changes, to save changes, click **Save**. To discard changes and restore previously saved settings or the factory default settings, click **Discard Changes**.

Changes to some System Settings require the camera to reboot; for example, on the [Network Page](#) and on the [Date & Time Page](#). After clicking **Save**, a confirmation message appears. To save the changes, and reboot the camera with the changes applied, click **Accept**. To close the confirmation message and remain on the page — without discarding the changes or saving them — click **Cancel** or click the close icon **X**.

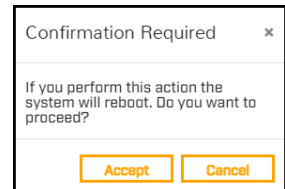

Tip

If you try to navigate away from the page before saving changes, a confirmation message appears. To leave the page, discard changes, and restore previously saved settings, click **Yes**. To close the confirmation message and remain on the page — without discarding the changes or saving them — click **No** or click the close icon **X**.

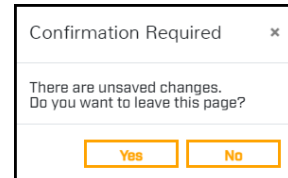

3.4 Video Page

The camera provides three video streams: two visible streams (V1 and V2) and one thermal stream (T1). Video streams are available for viewing using a client program or third-party ONVIF systems.

In general, it is not necessary to modify the default parameters. In some cases, such as when an IP video stream is sent over a wireless network, it can be useful to tune the video streams to reduce the bandwidth requirements. To modify the parameters for a particular video stream, click the relevant button (V1, V2, or T1).

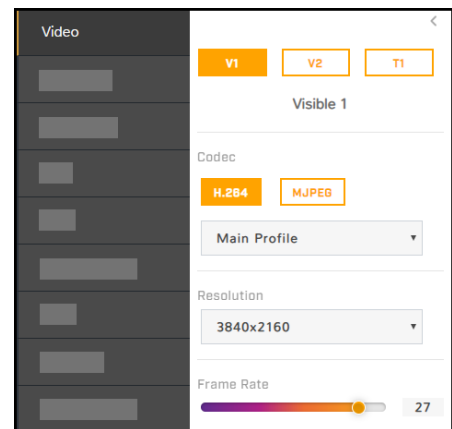

Tip

On the camera web page, the live video is not the actual video stream. Changes to stream settings might not affect the live video. Check any changes to stream settings using a client program or third-party ONVIF system.

Visible 1 / Visible 2

Codec options for the visible streams are H.264 or MJPEG.

Resolution options are 3840x2160 (4K), which is available only with H.264 encoding; 1920x1080 (1080p); 1280x720 (720p); and 640x480 (480p). The Frame Rate range is 5-30 FPS (frames per second).

When one stream's resolution is set to 3840x2160, the camera supports the following resolutions for the other stream:

One visible stream		Other visible stream	
Resolution	Frame rate	Resolution	Frame rate
3840x2160	> 15 FPS	640x480	≤ 30 FPS
	≤ 15 FPS	1280x720	
		1920x1080	

Thermal 1

Codec options are H.264 or MJPEG.

The resolution is 640x512 and the Frame Rate range is 5-30 FPS.

Codecs, Quality, and Bandwidth

The codec used determines which parameters you can set that have a significant impact on the quality and bandwidth requirements of the video stream. Use the default values initially, and then individual parameters can be modified and tested incrementally to determine when bandwidth and quality requirements are met.

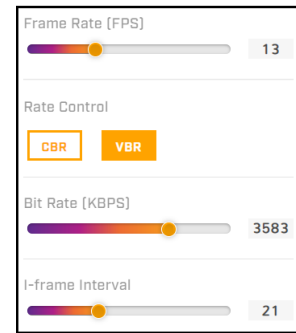

With the H.264 codec, you can set the:

- Rate Control:
 - CBR (constant bit rate): The Bit Rate parameter defines the target bit rate; the camera attempts to keep the video at or near the target bit rate.
 - VBR (variable bit rate): The Bit Rate parameter defines the average bit rate.
- I-frame Interval: Controls the number of P-frames used between I-frames. I-frames are full frames of video and the P-frames contain the changes that occurred since the last I-frame. A smaller I-Frame Interval results in higher bandwidth (more full frames sent) and better video quality. A higher I-frame Interval means fewer I-frames are sent and therefore can result in lower bandwidth and possibly lower quality.

With the MJPEG codec, you can set the Quality between 10-80. Setting a higher value can increase the video stream's bandwidth requirements.

Network Options

By default, multicast is enabled. Multicast video packets are shared by streaming clients. Additional clients do not cause bandwidth to increase as dramatically as with unicast. Video stream requests for ch0/stream1 are unicast. Client-specific multicast requests vary according to the client.

Enable Multicast

No Yes

Destination Network

224.1.1.1

Destination Port

61454

TTL

3

Visible 1

Enable Multicast

No Yes

Destination Network

224.1.1.2

Destination Port

61456

TTL

3

Visible 2

Enable Multicast

No Yes

Destination Network

224.1.1.3

Destination Port

61458

TTL

3

Thermal 1

If more than one camera is providing multicast streams on the network, make sure the Destination Network IP address is unique for each camera (the Destination Port can be reused). By default, the port assignment is unique per stream.

The time-to-live field controls the ability of IP packets to traverse network boundaries. A value of 1 restricts the stream to the same subnet. Greater values allow increasing access between networks.

The video streaming uses a protocol generally referred to as RTP, the real-time transport protocol, although there are actually a number of protocols involved, including the Real-Time Streaming Protocol (RTSP). The video stream URLs incorporate the IP address of the camera. Using the camera's default IP address, the complete URLs are:

- **Visible 1**—rtsp://192.168.0.250:554/stream1
- **Visible 2**—rtsp://192.168.0.250:554/stream2
- **Thermal 1**—rtsp://192.168.0.250:554/stream3

To maintain compatibility with legacy systems, the stream names are aliased as: ch0 = stream1, ch1 = stream2, and ch2 = stream3.

Accessing any of the camera's video streams requires authentication. You can use the name and password for any of the camera's users. See [Users Page](#).

3.5 Visible Page

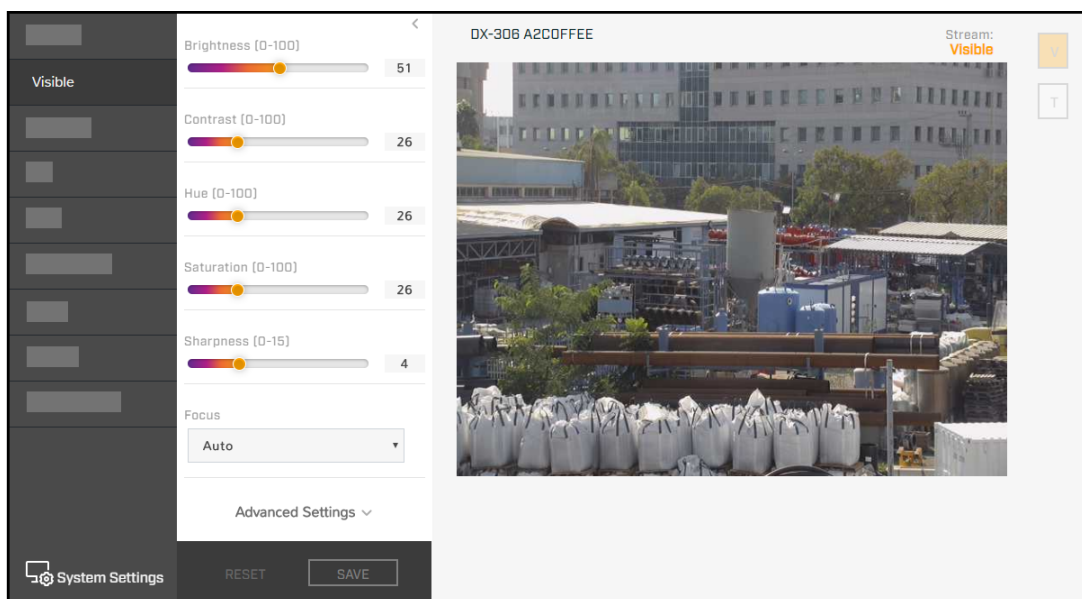

You can adjust the following visible video settings:

- **Brightness** (Gamma)
- **Contrast** (Max Gain)
- **Hue**
- **Saturation**
- **Sharpness**
- **Focus**—Select Auto for continuous auto-focus: The camera automatically and continuously maintains focus regardless of view changes. To manually focus the camera, select Manual and then click **Near** or **Far**.

Advanced Settings

- **Night Mode**—Set the visible video to:
 - **Color** (day mode)
 - **B/W** (night mode)
 - **Auto** (default)—Automatically switches the visible video mode according to light level. When Night Mode is set to Auto, you can set the thresholds at which the visible video switches from black and white to color (Night to Day Threshold) and vice versa (Day to Night Threshold). Move the sliders between 0-100, where 0 switches modes at a lower light level (darker) and 100 switches modes at a higher light level (brighter).

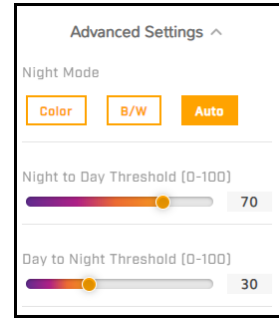

On the [Illumination Page](#), when infrared illumination is set to Auto and the scene becomes dark enough, the visible video automatically changes to B/W (night mode).

- **Wide dynamic range settings**

WDR improves the image quality and amount of detail in high contrast scenes. High contrast scenes consist of areas with different lighting conditions; some areas are bright and others are dark. Without WDR, either the bright areas would be overexposed (too bright) or the darker areas would be completely dark. WDR can produce more detail in both the dark and the bright areas of the image.

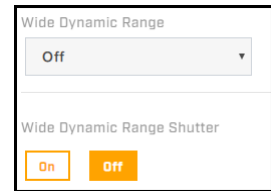

- **Wide Dynamic Range**—Set the level of digital Wide Dynamic Range (dWDR) to Off, Low (default), Mid, or High. When enabled, the camera digitally enhances the details in each frame.
 - **Wide Dynamic Range Shutter**—Enables True WDR. The camera combines two frames taken with slow- and fast-exposure shutter speeds into a single frame with a wide dynamic range, determining the optimal mix of regions within the scene.
- **White Balance**—Set according to operating environment:

- **Auto** (default)—Computes the white balance value output using color information from the entire screen. It is suitable for an environment with a light source color temperature in the range of approximately 2,700 ~ 7,500K.
- **One Push**—Click One Push Trigger to activate the factory-optimized setting for white balance. This setting might not be ideal for every lighting environment.
- **ATW** (Auto Tracking White Balance)—Automatically adjusts the white balance in a scene while temperature color is changing. It is suitable for an environment with a light source color temperature in the range of approximately 2500 ~ 10,000K.
- **Manual**—Define the Rgain and Bgain between 0-100 to increase the red and blue luminance.

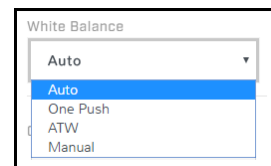

• **Noise reduction settings**

Noise reduction settings are used to reduce or eliminate artifacts that can limit the ability to positively identify an object. There are two types of noise: luminance and color (chroma) noise. 3D noise reduction and 2D noise reduction settings reduce luminance noise: dots of varying brightness levels (black, white, and gray). It is not recommended to completely eliminate luminance noise, which can result in unnatural images. The 3D Noise Reduction and 2D Noise Reduction settings should be configured after configuring Color Noise Reduction.

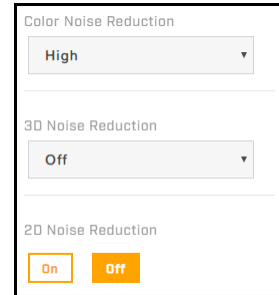

- **Color Noise Reduction**—Controls the noise appearing as red, green and blue dots between light and dark areas. Four settings are available: Off, Low, Mid, High. High maximizes the blending of the color noise with the image, effectively removing the dots, while Low minimizes the blending.
- **3D Noise Reduction**—Provides superior noise reduction and is recommended for use in extra low-light conditions. It is especially useful for reducing blur with moving objects. 3D noise reduction reduces image noise/snow in low-light conditions by comparing adjacent frames. A higher level of 3D noise reduction generates relatively enhanced noise reduction, although it creates more motion blur than 2D noise reduction on moving objects. Four settings are available: Off, Low, Mid, High.
- **2D Noise Reduction**—Analyzes individual frames pixel by pixel and frame by frame to eliminate environmental noise and deliver optimized image quality, especially in low-light conditions. 2D noise reduction tends to produce superior results for moving objects when applied to areas in the field of view where movement is present. However, it is less precise than 3D noise reduction. It can be set On or Off.

- **HLC (Highlight Compensation)**—Detects areas of the image overexposed by bright light sources such as headlights or spotlights and reduces image exposure only in these areas to enhance overall image quality. HLC works when Wide Dynamic Range Shutter is On.
- **Stabilization (Electronic Image Stabilization)**—Keeps the image steady and counteracts external vibration. To ensure calibration accuracy, after enabling stabilization, keep the camera still for three seconds. When Stabilization is On, the stabilization algorithm that processes the image slightly crops the video image. Available only when Wide Dynamic Range Shutter is enabled and cannot be enabled when Digital Zoom is On.
- **Digital Zoom**—Enable or disable digital zoom. Cannot be enabled when Stabilization is On.
- **Lidar Autofocus**—Enable or disable the camera's laser focus technology.
- **Exposure Mode**

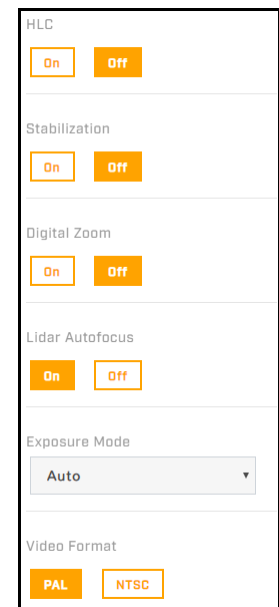

Exposure is the amount of light detected by the image sensor and is determined by the amount of time the shutter is open (shutter speed), and other exposure parameters.

- **Full Auto (default)**—The camera completely opens its shutter and automatically selects an exposure level using a programmed algorithm to achieve a consistent exposure output. Exposure priority is given to the iris. This mode is recommended for environments involving mixed lighting sources; for example, indoor scenes where the main source is fluorescent lighting, combined with natural light that enters the scene through windows and other exposed areas.

- **Manual**—Allows you to specify a fixed shutter speed, iris size, and gain. Generally used where light levels are fixed and the Full Auto mode does not provide the optimal exposure. This mode is recommended for scenes where there is a fixed lighting contrast and a constant, precise exposure is required; for example, some indoor scenes.

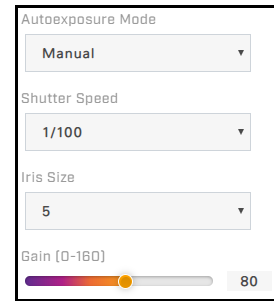

- **Shutter Speed**—Select a fixed shutter speed according to the environmental luminance. A slower shutter speed increases the amount of light entering the sensor and results in a brighter, more-detailed image. The Video Format determines the shutter speeds available, as shown in the following table.

NTSC				PAL			
1/30	1/120	1/500	1/3000	1/25	1/120	1/425	1/3500
1/60	1/180	1/725	1/10000	1/50	1/150	1/600	1/10000
1/90	1/250	1/1000	1/32000	1/75	1/215	1/1250	1/32000
1/100	1/350	1/2000		1/100	1/300	1/2500	

- **Iris Size**—The iris works in tandem with the shutter to determine how much light enters the sensor. Defining a larger iris increases the amount of light entering the sensor and results in a brighter, more-detailed image. With 0 (zero) being the smallest iris size, select a value between 0-9 or Full Open.
- **Gain**—A higher value increases the sensitivity of the image sensor, which brightens the image and adds details, but also increases the noise level. Define a value between 0-160.
- **Video Format**—When mounted indoors, the visible camera shutter speed can be synchronized to the 50 Hz or 60 Hz power used for lighting the scene. If lighting is connected to 50 Hz power, the PAL setting might provide better video and NTSC might provide better video under 60 Hz lighting.

3.6 Thermal Page

In most installations, it is not necessary to change the default settings of the thermal sensor. However, in some situations, depending on weather, time of day, or scene, modifying one or more parameters can improve the video stream image. Be aware that, when the conditions change, the parameters might need to be adjusted again. It is also a good idea to know how to restore the factory default settings (see [Firmware & Info Page](#)).

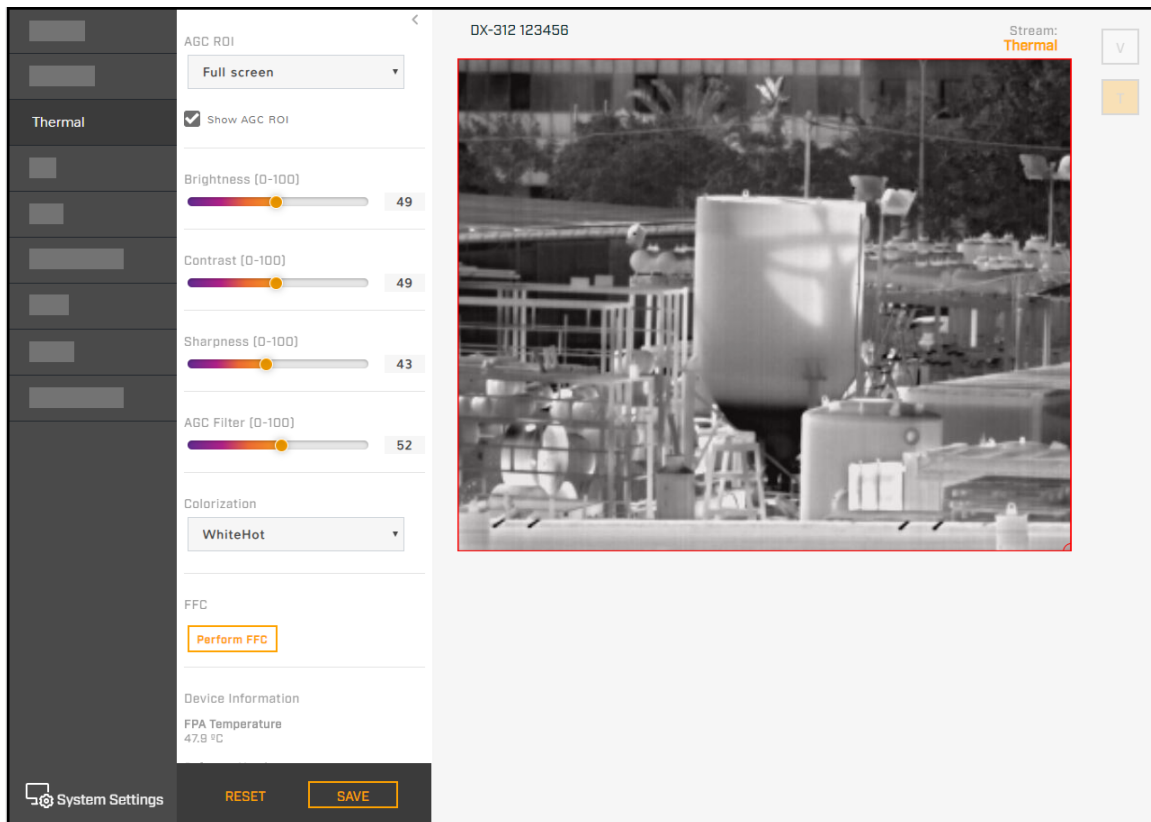

AGC ROI

The camera's Automatic Gain Control (AGC) algorithm adjusts the thermal video according to the region of interest (ROI). By default, the ROI is Full screen; the camera's AGC algorithm considers the entire image. In some cases, defining an ROI that excludes a portion of the screen can improve the image. For example, the sky is generally very cold. Defining the ROI to exclude the sky might improve contrast in the rest of the image.

In addition to Full screen, you can select from a number of preset options or manually define the ROI by selecting Custom.

By default, **Show AGC ROI** is selected and the AGC ROI appears as an overlay in the live video on the camera web page. The AGC ROI overlay does not appear in the video stream itself.



Tip

When **Show AGC ROI** is selected, the mouse pointer is used to define the AGC ROI and it is not possible to pan or tilt the camera. To use the mouse pointer to pan and tilt the camera, clear **Show AGC ROI** or close the thermal settings panel.

Defining a custom AGC ROI

To change the size of the ROI: Hover over the handle in the bottom-right corner of the ROI, and then click and drag it.



Resize

To move the entire ROI: Hover over the ROI, and then click and drag it.



Move

As soon as you manually change the size of the ROI or move it, the AGC ROI setting automatically changes to Custom.

AGC Image Settings

In some cases, changing the AGC image settings can provide a better image, depending on personal preferences, display devices, and so on.

- **Brightness (Gamma)**—Determines the allocation of the 256 “shades of gray” produced by the AGC. Values above 50 allocate more shades of gray to hotter objects, while values below 50 allocate more shades of gray to lower temperature objects. Range 0 to 100.
- **Contrast (Max Gain)**—Increasing contrast can provide a better image, especially for scenes with little temperature variation. (It might also increase noise due to the increased gain.) Range 0 to 100.



Tip

Changes to the default contrast setting affect scenes with little temperature variation more than they affect scenes with greater temperature variation.

- **Sharpness (DDE Gain)**—Enhances image details and/or suppresses fixed pattern noise. Range 0 to 100.
- **AGC Filter**—Determines how quickly a scene adjusts when a hot object appears (or disappears) within the AGC ROI. If set to a low value, when a hot object enters the ROI, the AGC will adjust more slowly to the hot object, resulting in a more gradual transition. Range 0 to 100.
- **Colorization**—Provides a selection of palettes for representing the detected levels of thermal energy as colors or gray-scale values. WhiteHot and BlackHot are grayscale palettes; other palettes assign different colors to different temperatures.

FFC (Flat-Field Correction)

At regular intervals or when the ambient temperature changes, the camera automatically performs FFC (also known as Non-Uniformity Correction or NUC). However, you can also manually trigger FFC by clicking **Perform FFC**. The shutter for the thermal sensor closes and provides a target of uniform temperature, allowing the thermal sensor to correct for ambient temperature changes and provide the best possible image. The thermal image momentarily freezes.

Focus (DX-606z model)

- **Focus**—Click Auto for continuous auto-focus: The camera automatically and continuously maintains focus regardless of view changes. To manually focus the camera, click Near or Far.

Advanced Settings

- **Equalization**—Method the camera's AGC algorithm uses to compress the 16-bit digital image data collected by the camera's thermal sensor into 8-bit display information (0-255):

- **Plateau**

- Redistributes output dynamic range proportional to the number of pixels in every irradiance range.
- Computes a histogram of all pixel values in the scene. The cumulative histogram maps data from 16-bit space to 8-bit space.
- Features additional optimizations that can modify how the histogram is calculated.

- **Information-Based (default)**

- Improves scene detail contrast by distributing output dynamic range proportional to the amount of scene information in every irradiance range.
- Uses a high-pass (HP) and low-pass (LP) filter to segregate scene data into details and background.
- Assigns a higher weight to pixel values in the HP image (details) when generating the histogram.
- Allocates more 8-bit shades to details.

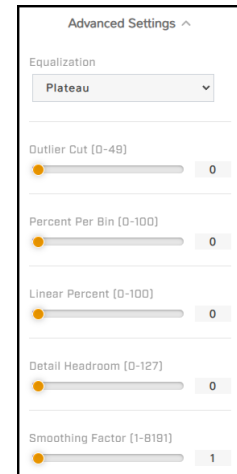

For both equalization types, you can configure:

- **Outlier Cut**—Percentage of outliers to ignore when mapping 16-bit data to 8-bit data (0-49; the default is 5). Improves overall contrast by excluding the most extreme portions of the scene that might be of less interest. By default, the camera disregards a total of 10% of the scene - 5% from the bottom of the histogram and 5% from the top - and optimizes mapping for the central 90%.
- **Percent Per Bin**—Maximum percentage for any histogram bin (0-100; the default is 7). Improves small object detail by limiting the number of shades allocated to large, mostly uniform portions of the scene. Because the setting is a percentage, you do not need to adjust it after modifying the AGC ROI.
- **Linear Percent**—Percentage of the histogram to allot to linear mapping (0-100; the default is 20). Provides a compromise between true linear AGC and non-linear AGC. Increasing Linear Percent can improve contrast.
- **Detail Headroom**—Defines the amount at the top and bottom of the 8-bit dynamic range to reserve for HP data / image details (0-127; the default is 30). Increasing Detail Headroom reduces contrast for LP data / background. Without Detail Headroom, contrast for HP data could be reduced due to applied gain.
- **Smoothing Factor**—Defines the frequency roll-off for the HP filter (1-8191; the default is 1250). Raising the Smoothing Factor increases the amount of HP data / image details. Teledyne FLIR recommends using the default Smoothing Factor.

3.7 Input/Output (I/O) Page

Adjust local and external I/O settings on the I/O page.

- For local I/O connections:

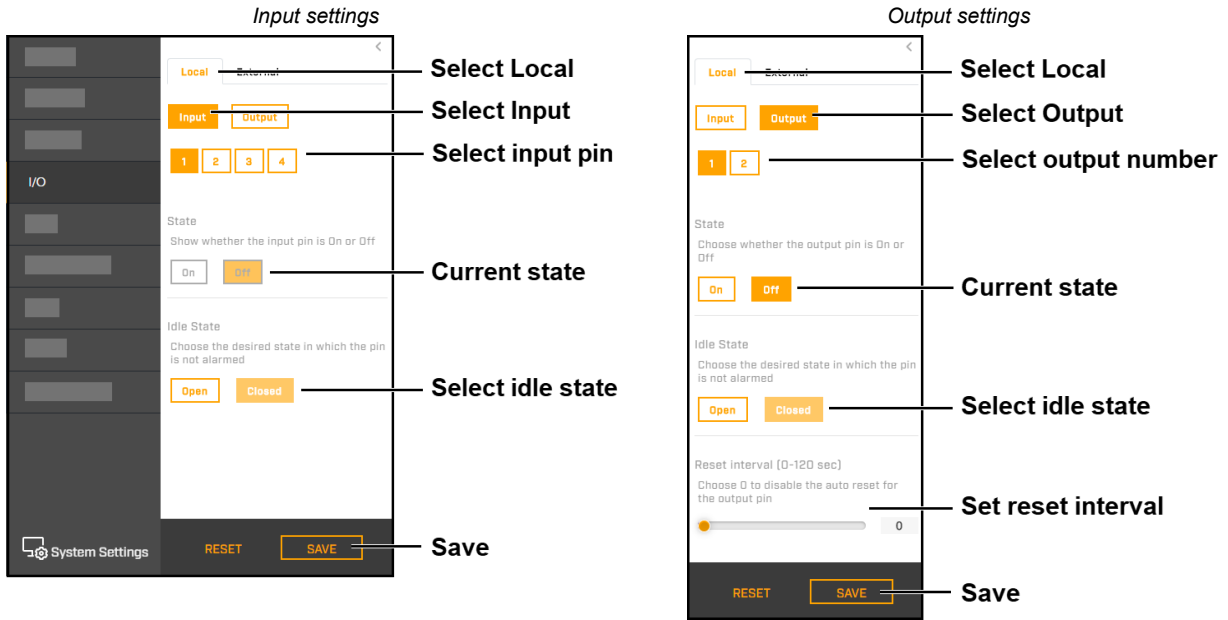

If an optional washer pump is connected to pins 3 and 4 (Alarm-Out A1 and A2) on the camera's 14-pin terminal block connector, the washer controls on the [Wiper Page](#) activate it through local output 1. For information about how to configure local output 1 to activate the washer pump, see [Install and Test the Optional Wash Kit](#).

For information about the local I/O connector, see [Connect the Camera](#).

- For external I/O connections, set the current state for the input and output pins, as shown at right.

You can configure the external I/O connections, including the number of external input and output pins, on the [I/O Devices Page](#) in System Settings.

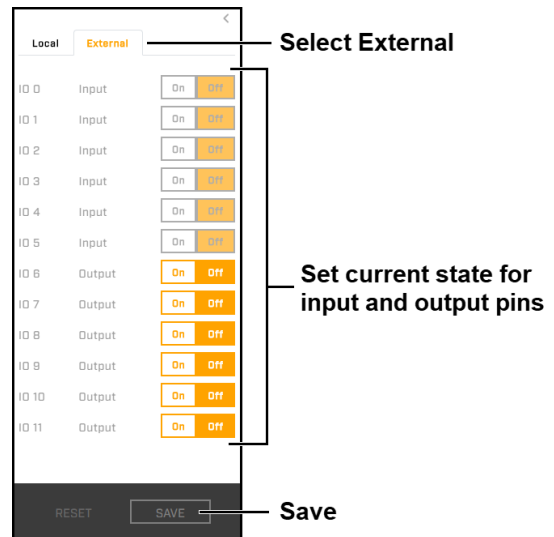

3.8 PTZ Page

Use the PTZ page to:

- Move the camera left, right, up, or down (pan and tilt)
- Define the pan and tilt speed, between 1x-10x
- Zoom in and out—click once or click and hold for continuous zoom
- Go to the camera's home position
- Set the camera's current position as its home position
- Define preset positions:
 - a. Under Preset Position, click **Set Preset**.
 - b. Select a preset index number from 1-128. Selecting an index number currently associated with a preset position overwrites the existing preset position.
 - c. Specify a unique, descriptive name for the preset position. You can use alphanumeric characters, underscores (_), or dashes (-).
 - d. Click **Set**. The camera adds the current position as a preset.

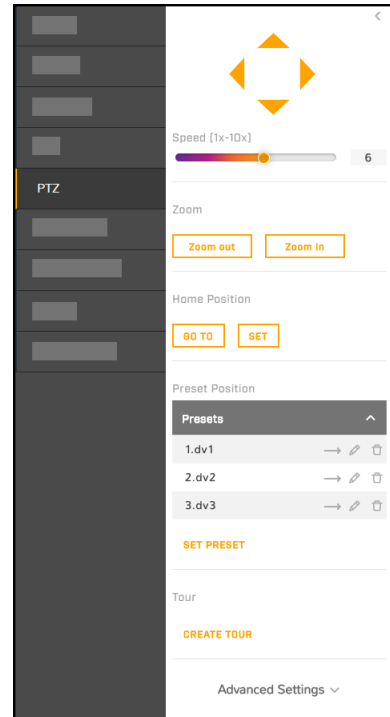
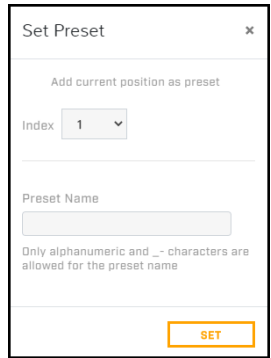

Preset positions are relative to the camera's orientation, which is defined on the [Georeference Page](#). If the camera's orientation changes and presets have been defined, redefine them with the new orientation setting.

- Move the camera to a preset position, edit a preset name, or delete a preset:

Under Preset Position, click **Presets**. The list of presets appears, in ascending index number order.

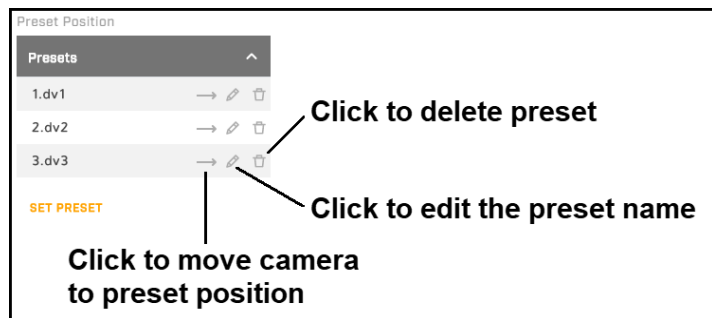

- Create and manage a tour of preset positions (only available if presets have been defined):

To create a tour, click **Create Tour**. For each tour stop, click **Add**, select a preset, and define the amount of time in seconds the tour stops at the preset.

You can also move tour stops up or down in the list and delete tour stops.

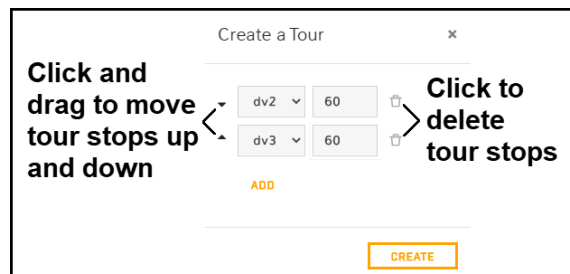

After you create a tour, you can start ▶, pause ||, stop ■, edit, or delete it.

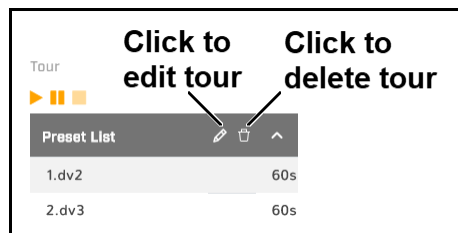

Advanced Settings

- **Startup Mode—**

- **None**—Factory default home position
- **Home Position**—User-defined home position
- **Tour**—Automatically starts tour of preset positions

When the camera is paired with a supported geotracking device, you can specify a geotracking mode.

- **Mechanical Flip**—Disable or enable the camera's mechanic flip feature. By default, Mechanical Flip is set to On and the camera can continuously track an object passing under the camera. When a tilting camera reaches its maximum angle, it pans 180° and then continues tilting to keep tracking the object.

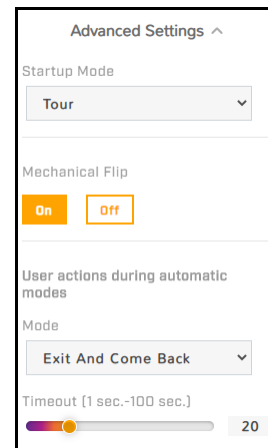



Note

If a preset position or a point for another function (for example, a tour) is set to a position that can only be reached by flipping the camera, when Mechanical Flip is set to Off, the camera cannot reach that position.

- **Geotracking Settings**—Available when this camera has been paired with a supported geotracking device - radar or camera - on the [Geotracking Page](#). For information about how to pair this camera, and how to configure this and other settings available when this camera is paired, see the geotracking device's documentation.
- **User actions during automatic modes**—You can specify the camera's behavior when a user attempts to manually move the camera during an automatic mode such as a tour:
 - **None** (default)—Disables manual camera movement.
 - **Exit**—The camera exits the automatic mode.
 - **Exit and Come Back**—The camera exits the automatic mode. After the specified **Timeout** or period of inactivity, between 1-100 seconds, the cameras resumes the automatic mode.

To add and enable a privacy masking zone:

1. In the live video, right-click the top-left corner of the zone you are adding, and then select **Start point**.

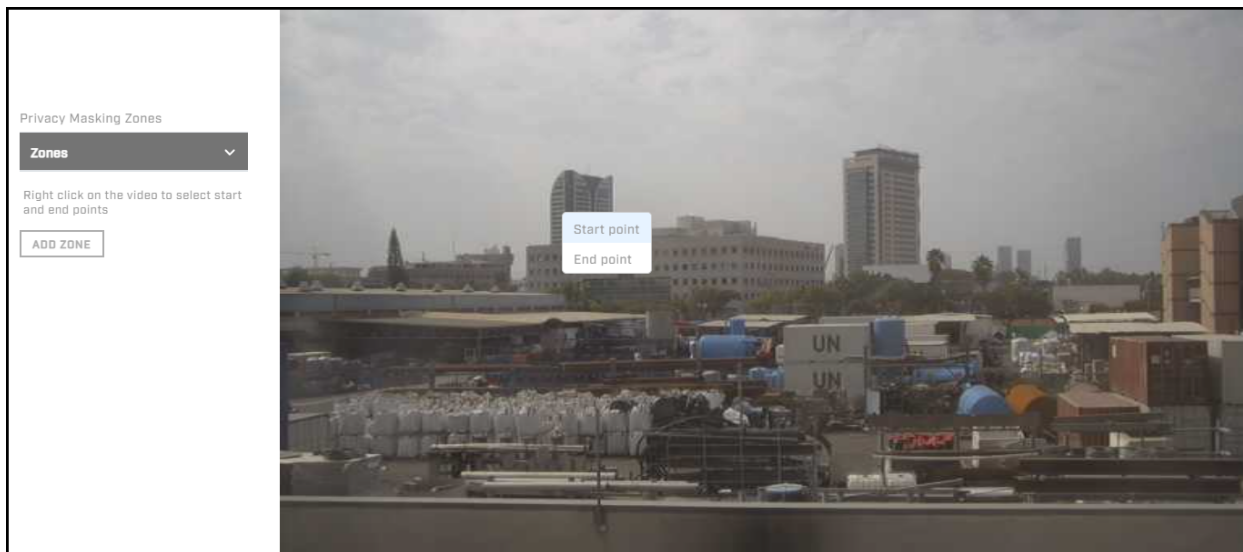

2. Right-click the bottom-right corner of the zone, and then select **End point**. The **Add Zone** button becomes enabled.
3. Under Privacy Masking Zones, click **Add Zone**. The Add Privacy Masking Zone window appears.
4. Specify a name for the zone, make sure it is enabled, and then click **Save**. The privacy masking zone appears in the live video and the zone appears in the list of zones.

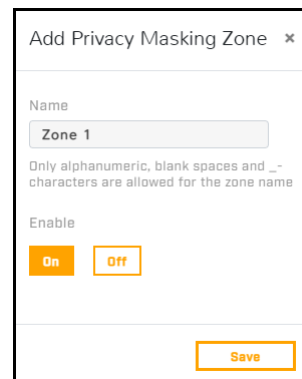



Privacy Zone Defined

3.9 Illumination Page

The camera features NIR illumination for the visible light camera. By default, infrared illumination is set to Auto; when the scene becomes dark enough, the infrared illumination turns on and the visible camera video changes to night mode (black and white video). You can set the night-to-day and day-to-night thresholds on the [Visible Page](#).

You can set the infrared illumination to Off.

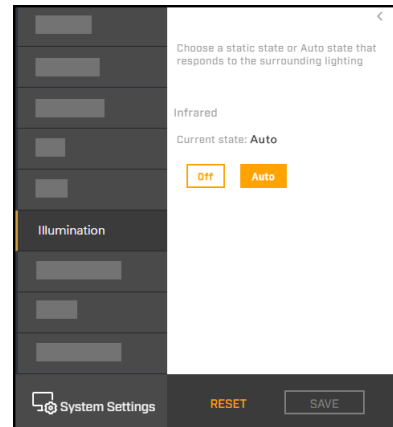

3.10 OSD Page

The OSD page provides separate on-screen display settings for visible and thermal video. The camera can overlay onto the video its name and the date and time:

- with either black or white text
- with or without a contrasting background in small, medium, or large size

Changes to OSD settings immediately take effect.

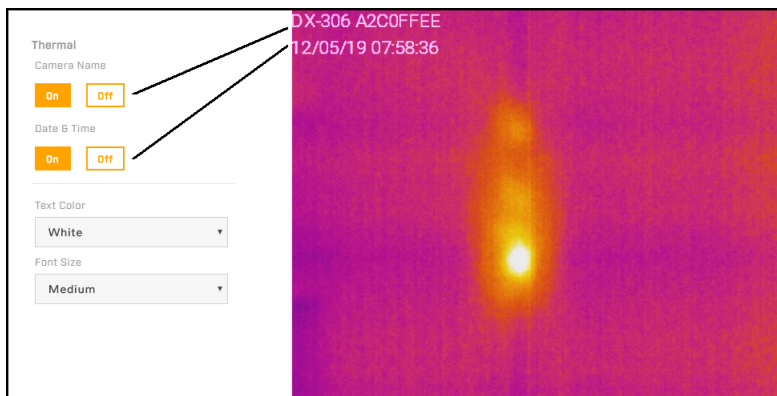

Thermal video with OSD

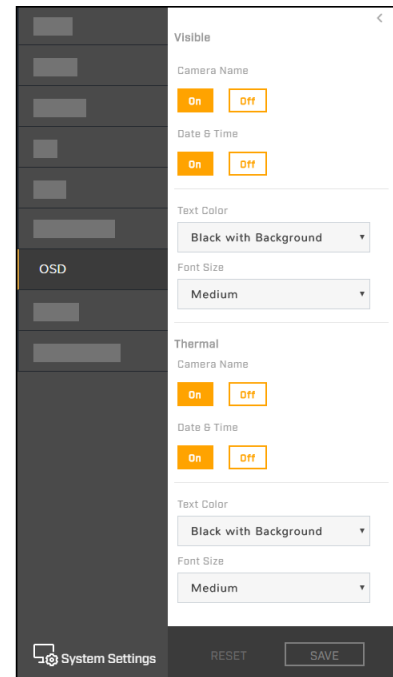

3.11 Wiper Page

The following settings and operations are available from the Wiper page :

- **Wiper**—Activates the camera lens window wiper. Click **Start** for one full wiper cycle.

Caution

Before activating the wiper, make sure the lens windows are wet. Using the wiper when the windows are dry causes irreparable damage to the window coatings and voids the warranty. Use the wiper with [an optional wash kit](#), wait until it rains, or spray the lens windows with a hose.

- **Washer device installed**—If you have installed an optional wash kit, click **On**. To apply changes to this setting, the camera needs to reboot.

When On is selected, the following washer controls are available:

- **Start**—Turns the washer on for the amount of time specified for the wash spray duration below. If the camera's pan and tilt is not in the washer position, the camera moves to the washer position. If the washer position has not been defined, define one.
- **Finish**—Turns the washer off. If the camera's pan and tilt is in the washer position, the camera moves back to its previous position.

Advanced Settings

- **Washer Position**

- **PTZ controls**—Moves the camera. Set the washer position so that the washer sprays liquid over both camera lens windows.
- **Go To**—Moves the camera to its washer position (if defined).
- **Set**—Sets the camera's current pan and tilt as its washer position.

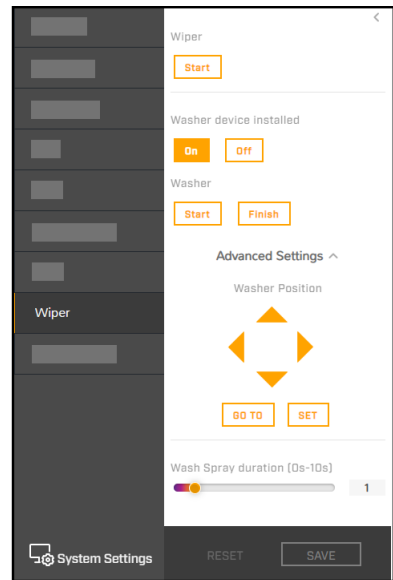

- **Wash Spray Duration**—Specify the amount of time the washer turns on when you click **Start** under Washer, between 0-10 seconds.

Important

If a wash kit is connected to the camera's Alarm-Out A1 and A2 pins on the 14-pin terminal block connector, these washer controls activate it through local output 1 (see [Input/Output \(I/O\) Page](#)). If another device is connected to the Alarm-Out A1 and A2 pins, the washer controls affect that device. If no device is connected to Alarm-Out A1 and A2, these controls only affect the camera's pan and tilt position (if a washer position is defined). For more information, see [Install and Test the Optional Wash Kit](#).

3.12 Georeference Page

On the Georeference page, you can specify the camera's geographical location and mounting information.

Pairing this camera with a FLIR Security device that supports [geotracking](#) requires proper and accurate georeference configuration.

- **Latitude**, in degrees North or South
- **Longitude**, in degrees East or West

Retrieve the camera's latitude and longitude coordinates by:

- Right-clicking on the display and then selecting **Georeference Sensor**.
- Manually specifying the coordinates, up to eight decimal places. To obtain the camera's latitude and longitude, you can use a map or a mobile GPS device.

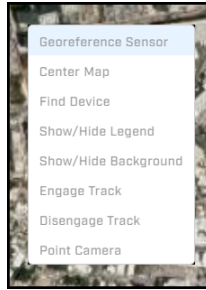

The camera immediately applies changes to the latitude and longitude settings. If a reference map has been uploaded and properly calibrated on the [Map Page](#) in System Settings, the camera icon moves accordingly. However, the camera does not automatically save these changes and does not move the detection range overlay. To save the changes, click **Save**. If you do not save changes within a few seconds, the camera restores the previous latitude and longitude settings, and moves the camera icon back.

- **Ground Altitude**, in meters above or below sea level, up to two decimal places
- **Installation Height**, in meters above the ground, up to two decimal places (must be greater than zero)
- **Installation Tilt**—camera mounting angle in the longitudinal (front-to-rear) axis, in degrees, up to three decimal places
- **Installation Roll**—camera mounting angle in the transversal (left-to-right) axis, in degrees, up to three decimal places
- **Orientation**—value that aligns the camera's detection range as it appears on a calibrated map, with the video field of view; between 0-360 degrees from North, up to two decimal places. For geotracking, the camera's orientation must be accurate and precise.

Digital Elevation Model—After [Creating a DEM File](#) and uploading it to the camera on the [Map Page](#), you can turn DEM on. When DEM is off, the camera does not adjust detected object tracking according to elevation.



Tips

- For geotracking, mount the camera horizontally level, so that it pans parallel to the horizon; the Installation Tilt and Installation Roll values should be 0 (zero).
- Preset positions are relative to the camera's Orientation setting. Changing the Orientation affects existing presets. After changing the camera's Orientation, go to the [PTZ Page](#) and redefine existing presets. The presets are also relative to the camera's Installation Tilt. If you have to change the Installation Tilt setting, redefine existing presets.



Tips (con't)

- Additional options when you right-click on the display are:
 - **Center Map**—If uploaded and calibrated, centers the map in the display.
 - **Find Device**—Centers the camera in the display. When the camera does not appear in the display window, select **Find Device**. For example, after you save the camera's coordinates or calibrate a map, the camera's position can be outside the display window.
 - **Show/Hide Legend**—Toggles the display legend.
 - **Show/Hide Background**—Toggles the map or other background image.
 - **Engage Track**—Camera engages the geotrack closest to the right-click point, and switches the [PTZ mode](#) to Single Track. You can use the Single Track mode to fine-tune this camera's georeference settings.
 - **Disengage Track**—Camera disengages the geotrack, and switches the [PTZ mode](#) to None. If the geotracking device loses the track, the PTZ mode switches to None. Changing the PTZ mode from Single Track automatically disengages the camera from the track.
 - **Show/Hide Background**—Toggles the map or other background image.
 - **Point Camera**—Moves the camera to the point where you right-clicked on the display.
- The camera's configuration files do not store factory default Georeference settings. To restore Georeference settings to the camera's factory condition, manually change them to zero (0).

Geotracking

You can pair this camera with a FLIR Security device that supports geotracking; for example, an FH-Series camera or an Elara R-Series radar. When paired, this camera engages and follows objects detected by the geotracking device. Those detected objects appear on the Georeference page display, along with the following information when present:

Icons and Descriptions			
	Fixed camera		Geotracking alarm region
	PTZ camera—a circle around this icon indicates the camera you are currently accessing / configuring		Geotracking exclusion region
	Radar		Detected object
	Geotracking detection range		Detected object in alarm region
	Visible camera detection range of circled camera		Object engaged by PTZ camera
	Thermal camera detection range of circled camera		

For information about how to pair this camera with a supported FLIR Security device that generates geotracking information, and how to configure this camera when it is paired, see the geotracking device's documentation.

Additional georeference applications

The camera can report georeference information using FLIR CGI/SDK or ONVIF, which:

- Allows the user or an application to:
 - Show the camera on a map

- Show the direction the camera is facing (using the camera's field of view, which the camera also reports)
- Supports pan and tilt cueing. For example, the FLIR CGI protocol provides pan and tilt commands to point the camera at a specific geographic location (latitude/longitude).

4 Configuration

Users assigned the admin or expert role can click **System Settings** on the [View Settings Home Page](#) to configure:

- [Networking](#)
- [Date and time](#)
- [User accounts and passwords](#)
- [Alarm settings](#)
- [Audio parameters](#)
- [I/O devices](#)
- [Cybersecurity](#)
- [ONVIF interface](#)

In addition, users assigned the admin or expert role can access the [Firmware & Info page](#) to upgrade the camera's firmware, reset the camera to its factory defaults, reboot the camera, and configure other parameters.

4.1 Network Page

The Network page provides [networking](#) and [SNMP](#) settings.

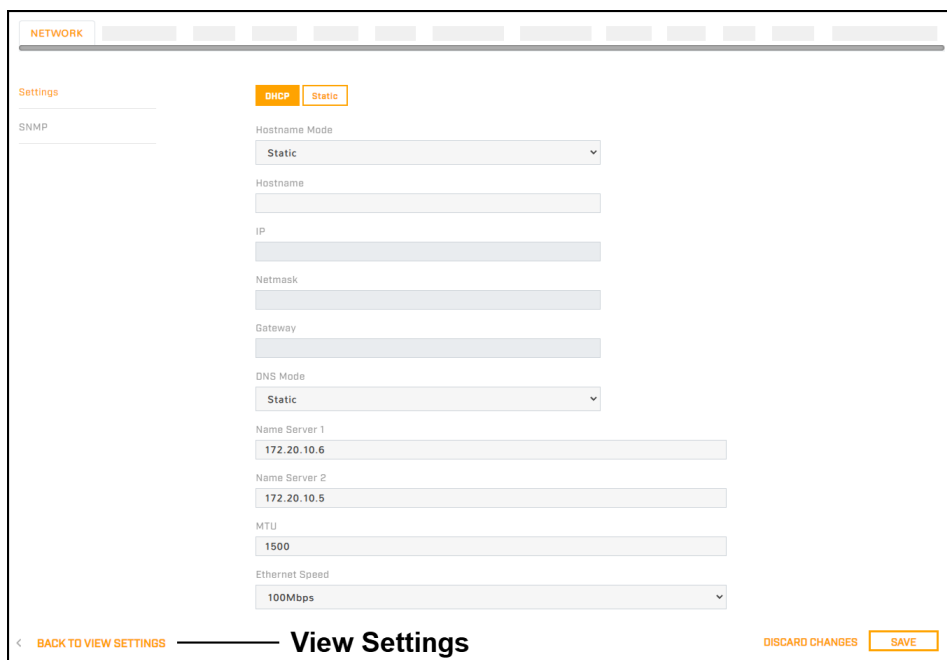

If you do not know how to configure these settings, contact your network administrator.

4.1.1 Settings

The DHCP (default) and Static buttons at the top of the page specify the IP addressing mode. If the IP addressing mode is set to DHCP but a DHCP server is not available on the network, the camera's IP address defaults to 192.168.0.250.

In Static IP addressing mode, specify:

- **IP**—The camera's IP address.
- **Netmask**—The default value is 255.255.255.0.
- **Gateway**

**Caution**

After changing the camera's IP address, the PC you are using to access the camera's web page might no longer be on the same network as the camera and can no longer access the camera's web page. To access the camera web page again, change the PC's IP address to be on the same network as the camera.

The Hostname Mode can be set to DHCP or Static (default); if set to Static, specify the hostname for the camera's server.

- **DNS Mode**—When the IP address mode is DHCP, you can set the DNS Mode to DHCP or Static. When the IP address mode is Static, the DNS Mode is also Static.

When the DNS Mode is set to Static, specify:

- **Name Server 1**—The primary domain name server that translates host names into IP addresses
- **Name Server 2**—A secondary domain name server that backs up the primary DNS

You can also specify the:

- **MTU**—Maximum transmission unit, the largest amount of data that can be transferred in one physical frame on the network. For Ethernet, the MTU is 1500 bytes (the default setting). For PPPoE, the MTU is 1492. Valid values are 1000-1500.
- **Ethernet Speed**—When set to 100Mbps (default), the camera supports 100Mbps. When set to Auto, the camera supports 10/100/1000 Mbps.

4.1.2 SNMP

In the SNMP section, you can enable and configure SNMP (Simple Network Management Protocol). SNMP allows network management systems to monitor and to remotely manage the camera. By default, all SNMP features are disabled.

**Important**

- For cybersecurity reasons, change the default community strings.
- If you are enabling SNMP, on the [Cyber page](#), make sure SNMP is enabled.

Enabled
 On Off
 Make sure SNMP is allowed in Cyber > Services

SNMP v1
 Enabled
 On Off

SNMP v2c
 Enabled
 On Off

Read Community String

Write Community String

Trap
 Enabled
 On Off
 Mode
 v2
 Trap Community String

 Target IP

SNMP v1—Enable SNMP v1.

SNMP v2c

After enabling SNMP v2, specify:

- **Read Community String**—Name of community that has read-only access to all supported SNMP objects. The default value is *public*.
- **Write Community String**—Name of community that has read/write access to all supported SNMP objects (except read-only objects). The default value is *private*.

SNMP v3

SNMP v3 provides security features including:

- **Confidentiality**—Packet encryption prevents snooping by unauthorized sources.
- **Message Integrity**—Ensures that packets have not been tampered with in transit, including an optional packet replay protection mechanism.
- **Authentication**—Verifies the message is from a valid source.

After enabling SNMP v3, specify:

- **User Name**—Name of user on network management system using SNMP v3.
- **Authentication Mode**—Select None (default), MD5, or SHA.
- **Authentication Password**—Password for authentication on network management system.

When an authentication mode is selected, specify:

- **Privacy Mode**—Select None (default), DES, or AES.
- **Privacy Password**—Password for privacy on network management system.

Trap

The camera uses traps to send messages to the network management system for important events or status changes.

After enabling traps, specify:

- **Mode**—Specify v1, v2 (default), or v3.
- **Trap Community String**—Name of community camera uses when sending traps to the network management system. The default value is *public*.
- **Target IP**—IP address of the network management system server.

4.2 Date & Time Page

Use the Date & Time page to configure the camera's date and time settings.

The camera can obtain the date, time, and time zone from an NTP server, or you can manually specify that information.

When set to Manual, you can copy the local PC's time or specify the hour, minute, second, and date.

When set to NTP, you can specify whether the camera obtains the NTP server information from the DHCP server on the network, or manually enter the NTP server information.

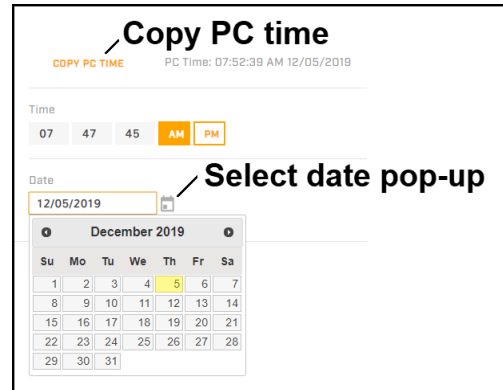

4.3 Users Page

Only users assigned the admin role can add users and change or set all passwords.

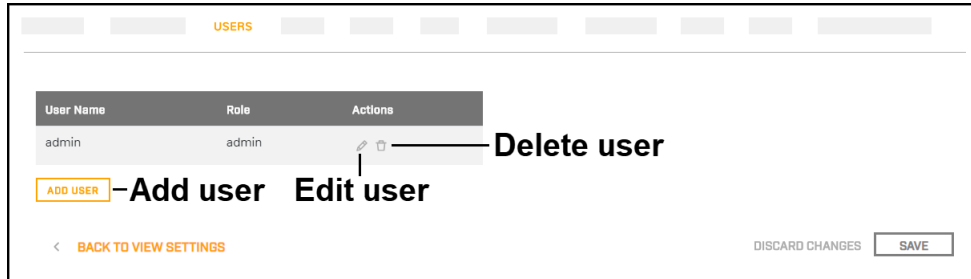

Users assigned the expert role only see the user currently logged in, and cannot add, edit, or delete a user.

To maintain security of the system, set up user names and passwords for each required login account.

Passwords must consist of at least 12 characters and include at least one uppercase letter, one lowercase letter, and one number. Passwords can include the following special characters: | @#~!\$<>+ _-.,*?= .

Assign one of the following roles, according to the level of access the user requires:

Role	Access
user	Can: <ul style="list-style-type: none"> View live video Switch between visible and thermal live video Pan, tilt, and zoom the camera, including toggling between the emulated joystick and crosshairs control View the Help page Log out
expert	Cannot manage users: <ul style="list-style-type: none"> Cannot add/edit/delete users Cannot change passwords Can access and use all other View Settings and System Settings pages, menus, controls, and settings
admin, including the default admin user	Can access and use all of the camera's web pages, including adding/editing/deleting users (but cannot delete the default admin user), and setting all passwords

All roles can access the camera's video streams, which require authentication. You can use the name and password for any of the camera's users.

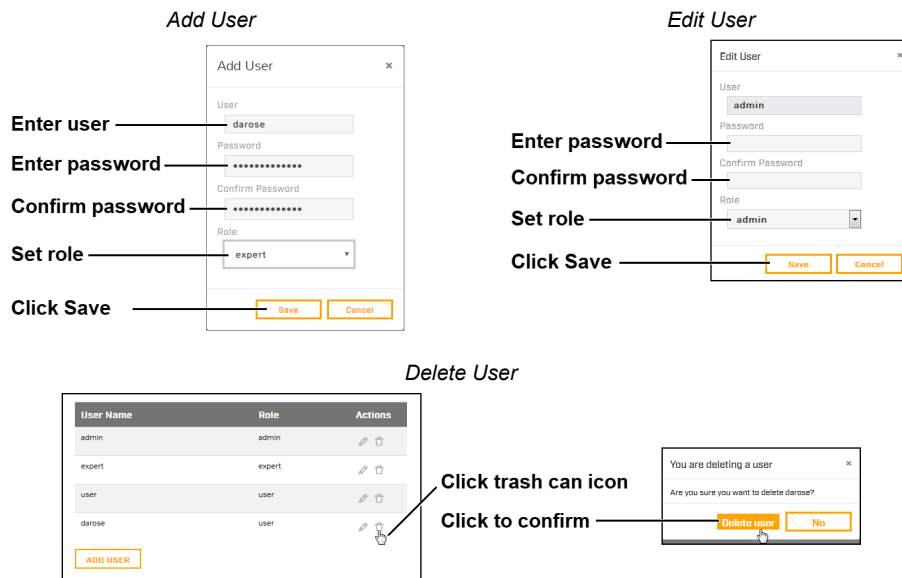

4.4 Cloud Page

The camera will support FLIR Cloud in a future release.

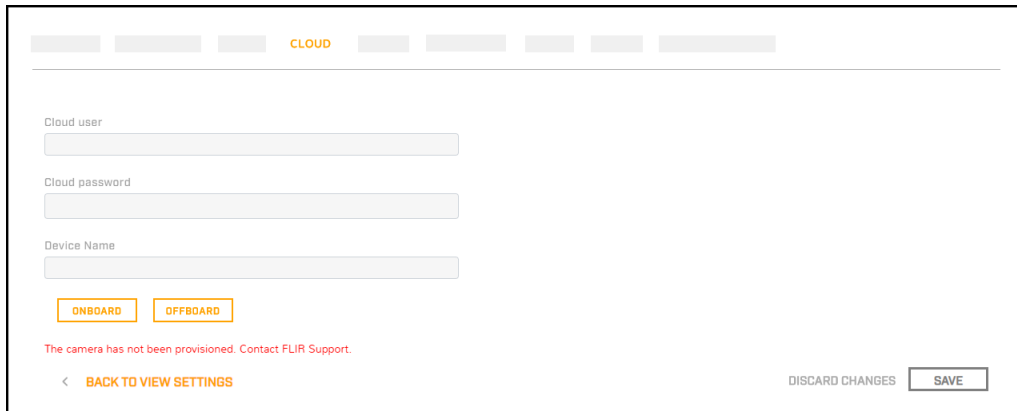

4.5 Alarm Page

You can define alarms to be triggered by:

- Local or external I/O connections
- A supported remote camera or other device (for example, an FH-Series camera or an R-Series radar)
 - Tampering
 - Video Analytics
 - Radiometry
 - Radar / geotracking

For each alarm, you can specify one or more of the following actions:

- Change the state of local or external I/O connections
- Send a notification email
- PTZ

To modify an existing alarm rule or define an alarm rule:

1. Click the alarm name or click **Create New**. The rule trigger settings appear.
2. [Modifying or Defining Rule Triggers](#)
3. [Modifying or Defining Rule Actions](#)

Enable or disable a rule by clicking **Enabled** or **Disabled**.

4.5.1 Modifying or Defining Rule Triggers

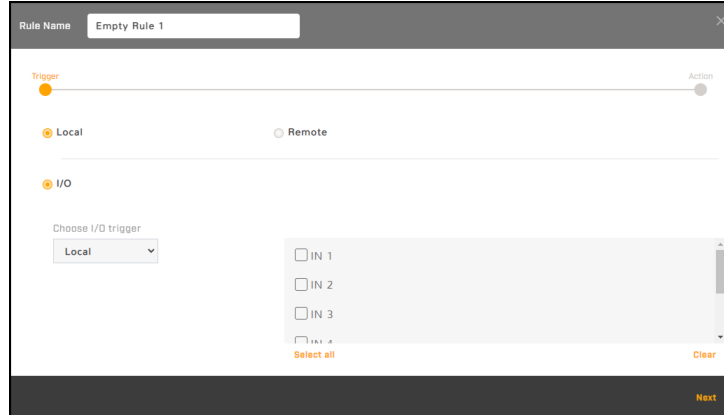

Rule Trigger Settings - Local Trigger - Local I/O Selected

1. Modify or define the rule name.
2. Select whether the triggers are local (onboard the camera) or remote (external):

Local Trigger		
I/O	<p>Local—This camera's local I/O connections trigger this rule's action.</p>	<ol style="list-style-type: none"> a. On the Input/Output (I/O) Page, make sure local I/O connectors have been properly configured. b. Select one or more local I/O connections that trigger this rule's action.
	<p>External—This camera's external I/O connections trigger this rule's action.</p>	<ol style="list-style-type: none"> a. On the Input/Output (I/O) Page and on the I/O Devices Page, make sure the external I/O connections and the device managing those connections with the camera have been properly configured. b. Select one or more external I/O connections that trigger this rule's action.

Remote Triggers
<p>Under Discovered Devices, select the remote camera, radar, or other device from the drop-down menu of supported devices on the same network as the camera; its IP address and port appear. You can also manually specify the remote device IP address and port, and then click Refresh to save it. Clicking Refresh also refreshes the drop-down menu of discovered devices. For example, if you just connected the remote device to the same network as the camera.</p>
<p> Note</p> <p>The camera discovers supported devices on the same network as the camera. However, to be used as a trigger, the device must be on the same VLAN as the camera.</p>

Remote Triggers		
Video Analytics	Video analytics from a supported remote camera or other device triggers this rule's action.	a. On the remote camera or other device, make sure video analytics are enabled and that at least one tripwire, intrusion detection / loitering region, or another analytics item has been defined. b. Select one or more video analytics items that trigger this rule's action.
Radiometry	Radiometry from a supported remote camera or other device triggers this rule's action.	a. On the remote camera or other device, make sure radiometry is enabled and that at least one radiometric item has been defined. a. Select one or more radiometric items that trigger this rule's action.
Geotracking	Geotracking from a supported radar or remote camera triggers this rule's action.	a. On the radar or remote camera, make sure detection or geotracking is enabled and that at least one alarm area, tripwire, or other area has been defined. b. Select one or more radar or geotracking areas that trigger this rule's action.

The following image shows a discovered FH-Series ID camera and its geotracking area 0 selected as the remote trigger.

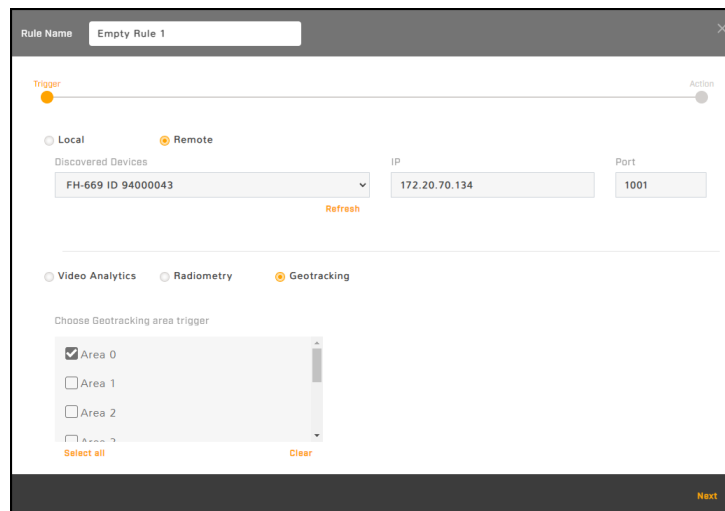

3. Click **Next**. The rule action settings appear.
4. Continue with [Modifying or Defining Rule Actions](#).

4.5.2 Modifying or Defining Rule Actions

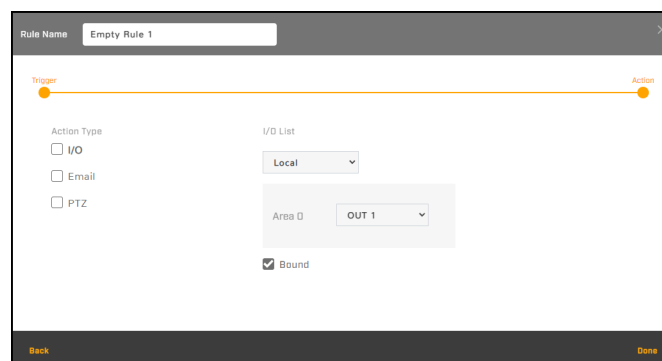

Rule Action Settings

To modify or define alarm rule actions:

1. For the alarm rule you are modifying or defining, select the checkbox for one or more action type.
2. To configure an action type, click the selected action type. The selected action type appears in **bold**, and the relevant settings appear.

I/O	Under I/O List, select Local or External.
	<p>Local—This rule changes the state of local I/O connectors.</p> <ol style="list-style-type: none"> a. On the Input/Output (I/O) Page, make sure local I/O connectors have been properly configured. b. For each trigger defined for the alarm rule, select the local output that changes.
	<p>External—This rule changes the state of external I/O connections.</p> <ol style="list-style-type: none"> a. On the Input/Output (I/O) Page and on the I/O Devices Page pages, make sure the external I/O connections and the device managing those connections with the camera have been properly configured. b. For every trigger defined for the alarm rule, select the external I/O connection that changes.
	<p> Tip</p> <p>You can map individual local or remote triggers to specific local or external outputs.</p>
	<p>Bound—When selected, the camera changes the state of the output when the alarm is triggered and when it is cleared.</p> <p>When not selected, the camera changes the state of the output when the alarm is triggered. However, the output state remains changed until it is reset according to the configured Reset Interval or by a command from the network. You can configure the Reset Interval for the local outputs on the Input/Output (I/O) Page and for the external outputs on the I/O Devices Page.</p>
<p>Email—When triggered, this rule sends a notification email according to the settings on the Messaging Page. Specify a subject for the email.</p>	
<p>PTZ—When triggered, this rule moves the camera to one of the presets defined on the PTZ Page. Specify the preset.</p>	

3. Click **Done**.

4.6 Audio Page

The Audio page provides configuration settings for the camera's audio input and output.

The On/Off buttons affect all audio input and output. Turning audio off immediately turns off all camera audio.

Audio In

When audio is On, the following audio input settings appear:

- **Encoding**—G.711.
- **Bit Rate**—The camera supports an audio input bit rate of 64 kilobits per second (kbps).
- **Sampling Rate**—The camera supports a sample rate of 8 kHz.
- **Enable Multicast**—Can be set to On (default) or Off. When On, specify the destination address and port, and the time-to-live (TTL).

AUDIO

On
Off

Turn camera audio on or off

Audio in

Encoding

Bit Rate (KBPS)

Sample rate (kHz)

Enable Multicast
On
Off

Destination Address

Destination Port

TTL

Audio out

Gain [0-100]
 70

Test
PLAY
STOP

< BACK TO VIEW SETTINGS
DISCARD CHANGES SAVE

Audio Out

When audio is On, you can adjust the audio line output gain from 0-100 percent. The default gain is 80 percent.



Tips

- Test whether the camera's audio output is functioning properly by clicking **Play**.
- If you are monitoring the audio IP output with a video stream and change any of the audio configuration settings except gain, restart the stream. For example, if you are monitoring a video stream and turn audio on, you need to restart the stream to hear the audio with the stream.

4.7 I/O Devices Page

The I/O Devices page provides configuration settings for external I/O connections and the device managing those connections with the camera.

I/O DEVICES

Enabled
Disabled

Device IP
 Address Port

Input base address Output base address

I/O pins

Number of Input pins Number of output pins

*Choose 0 to disable the auto reset for the output pin (0-600 sec) Refresh

I/O	Type	State	Idle State	Alarm Auto Ack	Enabled	Reset Interval [seconds]*
0	Input	Off	<input type="text" value="Open"/>	<input type="text" value="NO"/>	<input type="text" value="YES"/>	
1	Input	Off	<input type="text" value="Open"/>	<input type="text" value="NO"/>	<input type="text" value="YES"/>	
2	Input	Off	<input type="text" value="Open"/>	<input type="text" value="NO"/>	<input type="text" value="YES"/>	
3	Output	Off	<input type="text" value="Open"/>	<input type="text" value="NO"/>	<input type="text" value="YES"/>	<input type="text" value="0"/>
4	Output	Off	<input type="text" value="Open"/>	<input type="text" value="NO"/>	<input type="text" value="YES"/>	<input type="text" value="0"/>
5	Output	Off	<input type="text" value="Open"/>	<input type="text" value="NO"/>	<input type="text" value="YES"/>	<input type="text" value="0"/>

< BACK TO VIEW SETTINGS
DISCARD CHANGES SAVE

The following settings for the device managing the external I/O connections are available:

- **Enabled or Disabled**
- **Device IP address and port**
- **Input and output base addresses**

You can define the number of input and output pins the device manages.

The following information appears for each pin:

- **I/O pin number**
- **Type**—Input or Output
- **State**—the pin's current state: Open or Closed

For each pin, you can define the following:

- **Idle State**—Open or Closed
- **Alarm Auto Ack**—Yes or No
- **Enabled**—Yes or No
- **Reset Interval (for output pins only)**—between 0-600 seconds; specifying 0 seconds disables the auto reset

Related Operation and Configuration Information

For information about changing the current state of the input and output pins, see [I/O Page](#).

For more information about how to configure the device managing the external I/O connections, refer to the device's documentation.

4.8 Messaging Page

As [an action for an alarm rule](#), the camera can send a notification email using the mail server settings you can configure on the Messaging page.

The screenshot shows the 'MESSAGING' configuration page. Under the 'Email' section, there is a 'Mail Server Configuration' form. The form includes fields for 'Server IP Address' (smtp.example.com), 'User Name' (user@example.com), 'Server SMTP Port' (587), 'Password' (masked with asterisks), 'Authentication' (Yes), 'From Address' (from_address@example.com), and 'TLS Authentication' (Yes). Below this is a 'Notification List' section with an 'Email Addresses' field (to_address@example.com) and a 'Send' button.

Specify the settings for the SMTP server in the appropriate fields. Settings include the SMTP server's IP address; port (the default port is 587); user name and password for the account on the mail server; whether the mail server requires authentication or TLS authentication; and the email address from which the camera sends the notification emails (also known as the reply-to address). If you do not know the mail server's settings, contact your mail server administrator.

Under Notification List, specify one or more email addresses, separated by commas, to receive the notifications.



Tip

For the camera to properly send email, the camera's date and time must be correctly configured on the [Date & Time Page](#).

4.9 Cyber Page

The Cyber page provides security configuration settings for:

- [Certificates](#)
- [802.1x](#)
- [TLS/HTTPS](#)
- [Services](#)
- [IP Filter](#)

If you do not know how to configure these settings, contact your network administrator.

4.9.1 Certificates

Before you can enable TLS/HTTPS or 802.1X, you need to generate or upload a valid certificate:

- Use the camera's web page to generate a self-signed certificate.
- Upload a self-signed certificate.
- Upload a certificate signed by a third-party.

Certificates and keys must be in PEM format. Common file extensions for TLS files in PEM format are:

- **For certificate and public key files:** *.crt, *.cer, *.cert, *.pem
- **For private key files:** *.key

From the Certificates section of the Cyber page, you can download certificates and keys previously uploaded to or generated by the camera. If the certificate saved on the camera is self-signed, you can download the private and public key files. If the certificate was signed by a third-party CA, you can download the CA Certificate and the private and public key files.

To generate and install a self-signed certificate for TLS/HTTPS:



1. In the Certificates section and Certification area, select **TLS/HTTPS** and **Self-Signed**.
2. Enter information such as country code, city name, and organization name.
3. Click **Create Certificate**.
4. Allow 15 seconds for the camera to generate the certificate, at which point a confirmation appears.

To upload a self-signed or third-party CA signed certificate for TLS/HTTPS or for 802.1X:

1. In the Certification area, click **TLS/HTTPS** and then select **Upload Certificates**, or click **802.1x**.

To upload a certificate for TLS/HTTPS

To upload a certificate for 802.1X

2. If you are uploading a self-signed certificate, under **Public Key** and then under **Private Key**:
 - a. Click .
 - b. Select the appropriate key file.
 - c. Click .

If you are uploading a third-party CA signed certificate, select and upload the Public Key, Private Key, and CA Certificate.

3. Verify that the camera certificate files are valid and make sure *Certificates are OK* appears under the certificate information, under Download certificate.

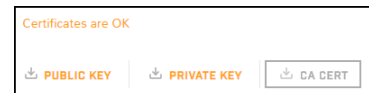

Note that you can download keys and certificates from the camera.

Changes in the Certificates section do not immediately take effect. To apply changes, click **Save** and then reboot the camera.

4.9.2 802.1x

Enable or disable IEEE 802.1X-compliant TLS communication.

Provide an Identity and Private Key Password.

Changing these settings does not immediately take effect. To apply a change to these settings, click **Save** and then reboot the camera.

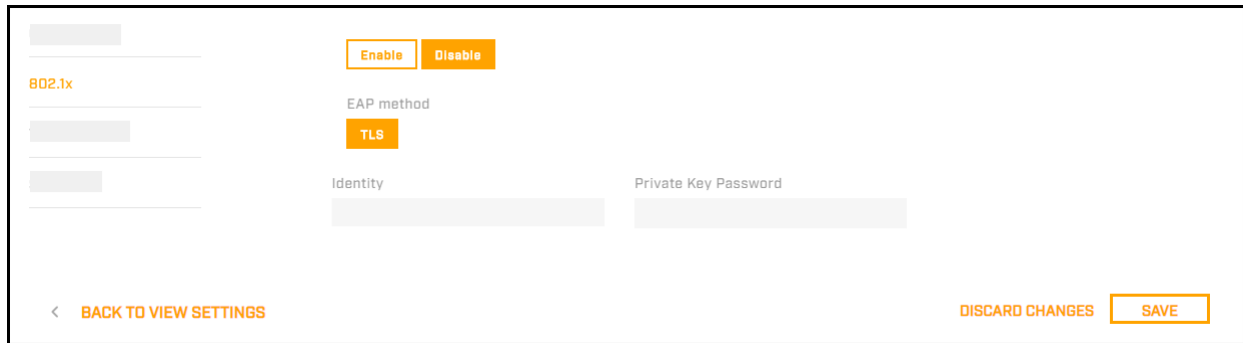

4.9.3 TLS/HTTPS

Enable or disable camera control using Transport Layer Security (TLS)/secure HTTP (HTTPS).

Enable or disable HTTPS redirect.

Changes to these settings do not immediately take effect. To apply the changes, click **Save** and then reboot the camera.

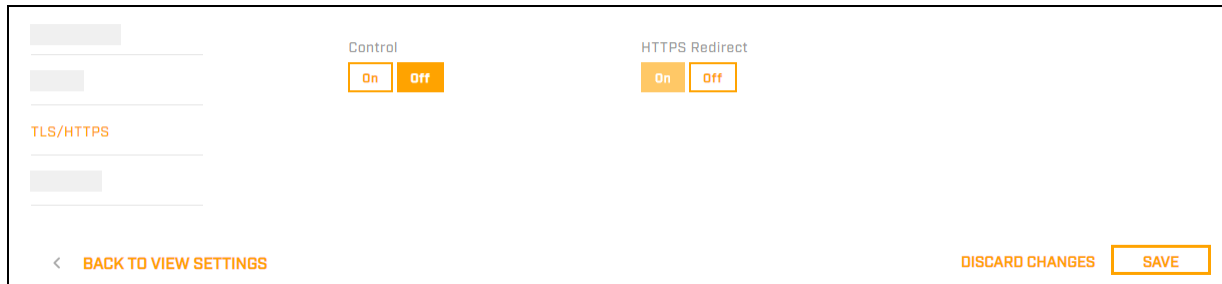

4.9.4 Services

Enable or disable digest authentication for the FLIR CGI control interface. The default setting is **On** (enabled).

Firewall Settings

For enhanced security, the camera has a firewall that you can enable by clicking **On**. By default, when you enable the firewall, the following services are set to **Allow**, which means they remain enabled and their default ports remain open:

- RTSP
- UPNP
- Nexus Discovery
- Nexus SDK
- ICMP
- SNMP

To disable a service and its default port, click **Block**.

Caution

Disabling services and ports can affect product functionality.

Changes to Services settings do not immediately take effect. To apply changes to these settings, click **Save** and then reboot the camera.

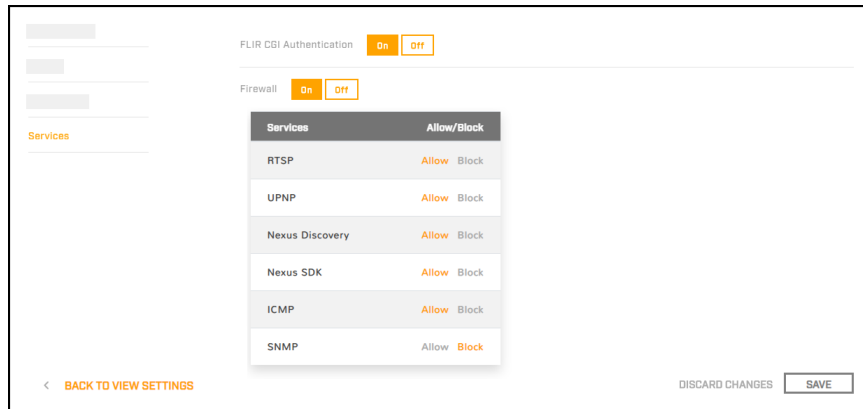

4.9.5 IP Filter

The camera's IP filter denies or allows access according to specific IPv4 addresses that you can define.

By default, the IP filter mode is Off.

To define specific IP addresses that can access the camera, click **Allow**. The camera will deny access to all other IP addresses.

To define specific IP addresses that cannot access the camera, click **Deny**. The camera will allow access to all other IP addresses.

To add an IP address to a list, either under Allowed IP Addresses or under Denied IP Addresses, specify an IPv4 address and then click **Add**. You can specify up to 256 IP addresses.

To remove an IP address from a list, click the corresponding trash icon .

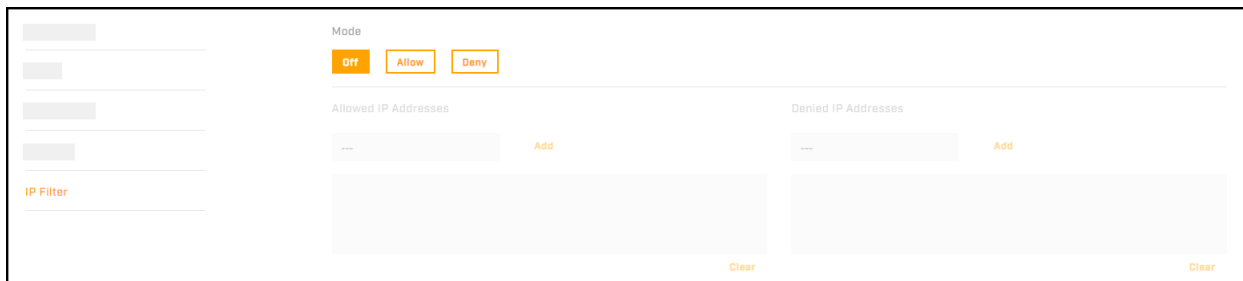

4.10 ONVIF Page

The ONVIF page provides settings for auxiliary commands and for output actions.

To configure the ONVIF interface:

1. Select the number of auxiliary commands (up to seven) and the number of output actions (also up to seven).
2. For each auxiliary command action, specify the ONVIF command name.
3. For each auxiliary command action, and separately for each ON and OFF output action, select one of the following:
 - o **None**
 - o **Thermal Polarity Toggle**—Toggles the thermal video polarity (see [Thermal Page](#)). For example, toggles the colorization from WhiteHot to BlackHot or vice versa; RedHot to RedHotInverse or vice versa; and so on.
 - o **Thermal Palette Toggle**—Toggles through the thermal video colorization options.

- **Thermal FFC**—Initiates flat-field correction on the thermal sensor.
- **Thermal Sharpness Toggle**—Toggles through thermal video sharpness settings.
- **P&T Start Tour**—If a tour is defined on the [PTZ Page](#), initiates a tour of pan and tilt preset positions.
- **P&T Stop Tour**—If a tour is defined on the [PTZ Page](#), stops the tour of pan and tilt preset positions.

The screenshot shows the ONVIF configuration interface. It is divided into two main sections: 'Auxiliary Commands' and 'Output Actions'. Both sections have a dropdown menu to set the 'Number of' items to 2. Below these are two tables. The 'Auxiliary Commands' table has columns for Index, Auxiliary Commands Name, and Action. The 'Output Actions' table has columns for Index, Action for ON, and Action for OFF. At the bottom, there are links for 'BACK TO VIEW SETTINGS', 'DISCARD CHANGES', and a 'SAVE' button.

Index	Auxiliary Commands Name	Action
0	AUX_NAME_0	Thermal Polarity Toggle
1	AUX_NAME_1	Thermal Palette Toggle

Index	Action for ON	Action for OFF
0	Thermal FFC	P&T Start Tour
1	Thermal Sharpness Toggle	P&T Stop Tour

4.11 Map Page

On the Map page, you can:

- Upload and calibrate a reference map image upon which the camera overlays its detection area on the [Georeference Page](#).
- Upload a digital elevation model (DEM).

The screenshot shows the 'MAP' configuration page. It features a 'Map Display' section with a warning about map calibration and a 'Find file' input with 'UPLOAD' and 'DOWNLOAD' buttons. Below is a 'Calibration' section with a warning and a table for two points (P1 and P2). To the right is a satellite image of a city area with yellow crosshairs indicating calibration points.

P1	X	Y	Lat	Lon
	106	96	32.1015475	34.84937704

P2	X	Y	Lat	Lon
	1820	730	32.09809836	34.86031508

Map Uploaded and Calibrated

To upload a reference map image and calibrate it:

1. Using an online map or GPS service such as Google Maps, download a reference map image.

For example, if you use Google Maps or another online map, you can take a screenshot of a satellite view of the camera's detection range. In Windows 10, you can use the default keyboard shortcut

(Windows logo key  + Shift + S) to take the screenshot, paste the screenshot into an image editor (for example, Paint), and then save the image in JPG or PNG format. The size of JPG files are optimized better.



Tips

- When you take the screenshot, make sure that north is straight up in the map image and that the map is flat (2D).
- Use a large, high-resolution screen or display in its native resolution with no zoom.



Tips (con't)

- You might get better results taking the screenshot with the map source in full screen (in Google Chrome, press F11). Also, in Google Maps, for example, it might help to turn off labels.
- Keep in mind where the camera is or will be mounted and oriented, and take a screenshot that covers an area a little larger than the camera's maximum detection range.
- The quality and resolution of the map image should be high enough so that the reference map is useful when you zoom in on the detection area display.
- To move the map, and to zoom in and out, you can use the mouse. To move the map, click on it, hold, and drag. To zoom in or out, use the mouse scroll wheel.
- It might take a few attempts at different settings to achieve the best result.

2. Identify two calibration points for which you can obtain accurate and exact latitude and longitude coordinates. For example, intersections of two roads or highways.

For optimal calibration, the two calibration points should be as far apart as possible and on opposite sides of the map image. For example, at top-right and at lower-left.

3. Under Map Display, click **Find file**, and then click **Upload**.

If the map successfully uploads, a confirmation message appears.

4. Click **Accept**.

If a map does not successfully upload, try again. Try changing the quality or compression of the map image. Higher quality or lower compression increases the map file size.

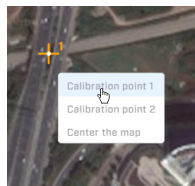

Right-Click on Map

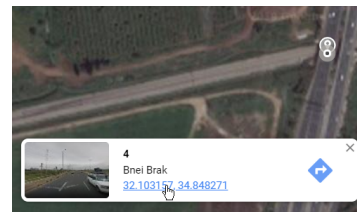

Google Maps > Right-Click

5. Right-click on the first calibration point, and then select Calibration point 1.
6. Enter the latitude (Lat) and longitude (Lon) coordinates for the first calibration point (P1). You can obtain the coordinates from the online map or from a GPS service.

For example, when using Google Maps, right-click on a point and select the coordinates. The point's latitude and longitude coordinates are copied to the clipboard. Paste the coordinates into the P1 **Lat** and **Lon** fields.

The calibration point appears in the map as a crosshairs icon.

7. Repeat steps 4 and 5 for the second calibration point (P2).
8. Click **Save**.

The camera calibrates the map. When a map is not calibrated, a message appears onscreen.

**Tip**

Even though it is not possible to delete an uploaded map image, you can upload a black image and replace the existing map. On the [Georeference Page](#), information appears on the black image.

To upload a digital elevation model, click **Find file**, click **Upload**, and then click **Save**.

If you have not yet configured the camera's georeference settings, you can do so on the [Georeference Page](#).

4.12 Geotracking Page

On the Geotracking page, you can enable pairing this camera with a FLIR Security device that supports geotracking; for example, an FH-Series camera or an Elara R-Series radar.

Device Name	IP	Port	Select
R-290 405	172.20.70.139	1001	<input type="radio"/>

For information about how to pair this camera with a supported geotracking device, including how to configure this camera when it is paired, see the geotracking device's documentation.

4.13 Firmware & Info Page

Use the Firmware & Info page to:

- Specify a unique name for the camera
- Upgrade the camera's firmware
- Upgrade the firmware for the camera's thermal sensor
- Reset the camera to its factory defaults
- Reboot the camera
- Define a log level and download system information
- Enable the compatibility mode for legacy VMS versions

Name

Specify a unique, friendly name for the camera, using only alphanumeric characters. The default name for the camera is the camera model followed by the camera's serial number.

To upgrade the camera's firmware:

1. Make sure the camera has been recently rebooted.
2. Under Upgrade version, click **Find file**.
3. On your computer or network, browse to and select the firmware file.

 **Caution**

Only upgrade to firmware developed for Elara DX-Series cameras.

4. Click **Upgrade**.

The camera uploads and installs the firmware, which takes a minute or two. After installing firmware, the camera requires a reboot. When prompted, confirm rebooting the camera.

Thermal Sensor Firmware **Caution**

Upgrading the thermal sensor firmware cannot be undone.

To check whether an upgrade is available, make sure that the camera is connected to the Internet and then click **Check for Upgrade**.

If an upgrade is available, a message appears.

To upgrade the firmware, click **Accept**.

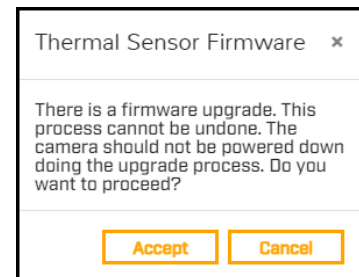
**Factory Defaults**

Click **Full Reset** to return the camera its original factory configuration.

Click **Partial Reset** to keep the current settings on the Network page and return all other settings to their factory defaults.

Click **Reboot** to cause the camera to power cycle and reinstall configuration files.

 **Tip**

You can also return the camera to its original factory configuration by pressing the camera's physical Default button for at least 20 seconds; for example, if you are unable to access the camera via its web page or other communication method. The Default button is located on [the camera's connector panel](#).

Support System Info

Set the logging detail up to four levels; higher log levels increase the size of the log file.

Click **Download** to retrieve the camera's log files.

Other settings

For legacy VMS versions, enable the compatibility mode.

5 Maintenance and Troubleshooting Tips

If help is needed during installation, operation, or configuration, contact the local Teledyne FLIR representative or visit <https://support.flir.com/>. Teledyne FLIR offers a comprehensive selection of training courses to help get the best performance and value from the thermal imaging camera.

Find out more at the Teledyne FLIR training web page: <https://www.flir.com/support-center/training/>.

5.1 Cleaning

Great care should be used with your camera's optics. They are delicate and can be damaged by improper cleaning. The camera's lens windows are designed for a harsh outdoor environment and are coated for durability and anti-reflection. However, they can require occasional cleaning. If you are not using an optional wash kit, Teledyne FLIR suggests that you clean the lens windows when you notice image quality degradation or excessive contaminant build-up on them.



Note

Do not disturb or move camera during cleaning.

Rinse the camera housing and optics with low pressure fresh water to remove any salt deposits and to keep it clean. If the front window of the camera gets water spots, wipe it with a clean soft cotton cloth dampened with fresh water.

Do not use abrasive materials, such as paper or scrub brushes, as this can damage the lens window by scratching it. Only wipe the lens window clean when you can visually see contamination on the surface.

Use the following procedure and solvents, as required:

- Acetone – removal of grease
 - Ethanol – removal of fingerprints and other contaminants
 - Alcohol – final cleaning (before use)
1. Immerse lens tissue (optical grade) in Alcohol, Acetone, or Ethanol (reagent grade).
 2. With a new tissue each time, wipe the lens window in an “S” motion (so that you do not wipe any area more than once).
 3. Repeat until the lens window is clean. Use a new tissue each time.



Caution

The DX-608 camera model does not have a silicon window protecting its germanium thermal camera lens.

5.2 Troubleshooting

No Video

If the camera will not produce an image, check the connections at the camera and at the display. If the connectors appear to be properly connected but the camera still does not produce an image, ensure that power has been properly applied to the camera and the circuit breaker is set properly. If a fuse was used, be sure the fuse is not blown.

If the camera still does not produce an image, contact the Teledyne FLIR dealer or reseller who provided the camera, or contact Teledyne FLIR directly.

Performance of Thermal Sensor Varies with Time of Day

There may be differences in the way the thermal sensor performs at different times of the day, due to the diurnal cycle of the sun. Recall that the thermal sensor produces an image based on temperature differences.

At certain times of the day, such as just before dawn, the objects in the scene may all be roughly the same temperature. Compare this to imagery right after sunset, when objects in the scene may be radiating heat energy that has been absorbed during the day due to solar loading. Greater temperature differences in the scene will allow the thermal sensor to produce high-contrast imagery.

Performance may also be affected when objects in the scene are wet rather than dry, such as on a foggy day or in the early morning when everything may be coated with dew. Under these conditions, it may be difficult for the thermal sensor to detect the temperature of the object itself, rather than of the water coating.

Thermal Image Freezes Momentarily

By design, the camera image momentarily freezes during Flat-Field Correction (FFC, and also known as Non-Uniformity Correction or NUC). At regular intervals or when the ambient temperature changes, the camera automatically performs FFC. You can also manually trigger FFC on the [Thermal page](#). The shutter for the thermal sensor closes and provides a target of uniform temperature, allowing the thermal sensor to correct for ambient temperature changes and provide the best possible image.

Unable to Communicate over Ethernet

First check to ensure the physical connections are intact and that the camera is powered on.

By default the camera will broadcast a discovery packet two times per second. Use the Teledyne FLIR Discovery Network Assistant (DNA) tool or a packet sniffer utility such as Wireshark and confirm the packets are being received by the PC from the camera.

Unable to View Video Stream

If the video stream from the camera is not displayed, it could be that the packets are blocked by the firewall, or there could be a conflict with video codecs that are installed for other video programs.

When displaying video with a VMS for the first time, the Windows Personal Firewall may ask for permission to allow the video player to communicate on the network. Select the check boxes (domain/private/public) that are appropriate for the network.

If necessary, test to make sure the video from the camera can be viewed by a generic video player such as VLC media player (<http://www.videolan.org/vlc/>). To view the video stream, specify RTSP port 554 and the appropriate stream name. For example, using the camera's default IP address when there is no DHCP server on the network (192.168.0.250):

rtsp://192.168.0.250:554/stream1 for Visible 1

rtsp://192.168.0.250:554/stream2 for Visible 2

rtsp://192.168.0.250:554/stream3 for Thermal 1



Accessing any of the camera's video streams requires authentication. You can use the name and password for any of the camera's users. See [Users Page](#).





Refer to [Network Options](#) for additional information on RTP settings and stream names.

6 Appendices

6.1 Mounting Accessories

Teledyne FLIR offers the following mounting accessories and adapters for DX-Series cameras:

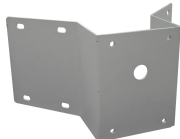
Part number / item code	Description and notes	Images (not to scale)
CX-XTND-G3	Extendable gooseneck mount kit (1.5" PF inner threaded) with cable box Dimensions 915-1165 (L) x 925 (H) x 256 (W) mm Color White Shipping box size 90 x 55 x 17.5 cm Shipping box weight 14.3 kg	
CX-GSNK-G32	Gooseneck mount kit (1.5" PF inner threaded), including base and gooseneck pipe Dimensions ∅ 113 x 838 (L) x 450 (W) mm Weight 5.56 kg Color White Shipping box size 90 x 55 x 15 cm Shipping box weight 6.59 kg	
CX-GSNK-G32-B	Gooseneck mounting bracket Dimensions 220 (L) x 125 (W) x 47.5 (H) mm Weight 1.09 kg Color White Shipping box weight 1.2 kg	

Part number / item code	Description and notes	Images (not to scale)
CX-DRP-G32-B	Ceiling mount kit (1.5" PF inner threaded), including base and 20cm drop-down pipe Dimensions \varnothing 165 x 257.5 mm Weight 0.94 kg Color White Shipping box weight 1.03 kg	 <p style="text-align: center;">Base</p>
CX-PIPE-G325	50cm long extender pipe (1.5" PF outer & inner threaded) Dimensions \varnothing 54 X 520 mm Weight 1.6 kg Color White Shipping box weight 1.67 kg	<p style="text-align: center;"><i>Image not available</i></p>
CX-ARMX-G3	Wall mount bracket (1.5" PF inner threaded) Dimensions 250 (L) x 140 (W) x 228(H) mm Color White Shipping box size 31 x 77 x 48 cm Shipping box weight 13.65 kg	
CX-ELBX-G3	Wall mount (1.5" PF inner threaded) with IP68 electrical box enclosure Dimensions 316 (L) x 185 (W) x 228(H) mm Color White Shipping box size 45.5 x 32 x 47 cm Shipping box weight 13.4 kg	
CX-GSNK-G3	Gooseneck mount (1.5" PF inner threaded) with IP68 electrical box enclosure Dimensions 491 x 256 x 1084 mm Color White Shipping box size 90 x 57 x 20 cm Shipping box weight 14.55 kg	
CX-CRNR-G3	90-degree exterior angle corner mount adapter for use with CX-xxxx-G3 mounts Dimensions 400 (L) x 242 (D) x 200(H) mm Color White Shipping box size 45 x 40.5 x 42 cm Shipping box weight 29.01 kg	
CX-POLE-G3	Pole mount adapter kit for use with CX-xxxx-G3 mounts, including straps Pole diameter range \varnothing 150-230 mm (2.5-8.5") Dimensions 240 (L) x 161(w) x 72.5 (D) mm Color White Shipping box size 37 x 26.5 x 37.5 cm Shipping box weight 17.8 kg	
CP-63CLEAR-P	Clear bubble for CP-6302-31-P Dimensions \varnothing 193 x 127.7 (max) mm Color FLIR White Shipping box size 260 x 255 x 170 mm Shipping box weight 0.60 kg	<p style="text-align: center;"><i>Images not available</i></p>

Part number / item code	Description and notes	Images (not to scale)
CP-63SMOKE-P	Smoked bubble for CP-6302-31-P	

6.2 Creating a DEM File

Creating a digital elevation model (DEM) file that you can upload to the camera involves:

- Retrieving the latitude and longitude coordinates for the top-left and bottom-right corners of an area that includes the camera's full field of view
- Defining and creating the grid for the DEM
- Using a GPS visualization website to generate a file with elevation data for the grid and then to generate a DEM file that you can upload to the camera

To create a DEM file that you can upload to the camera:

1. Download the **DEM.zip** file from <https://flir.box.com/v/DigitalElevationModelFiles> and extract the files.
2. Using a map service (for example, Google Maps or Google Earth), retrieve the latitude and longitude coordinates for top-left and bottom-right corners of an area that includes the camera's full field of view.

For example, in Google Maps, right-click on a corner and select **What's here?** Latitude and longitude coordinates appear. Click the coordinate link, and then you can copy and paste the coordinates.

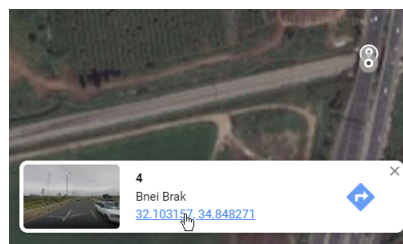

What's here? in Google Maps

3. In the extracted folder, open **DEM_GridSettings_Input.txt**. Then, edit the content by changing the pre-existing values to:
 - **TopLeft=latitude,longitude**
 - **BottomRight=latitude,longitude**
 - **CellSize=the length / width in meters for each cell in the grid**—Depending on the overall area of the grid, if the CellSize pre-existing value of 10 generates a DEM file that is too large to upload to the camera, increase the CellSize to 20 or 30 and try again.

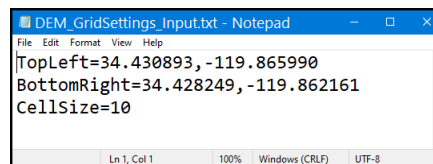

DEM_GridSettings_Input.txt with Pre-existing Values

4. Run **createMapGridCoordinates.exe**.

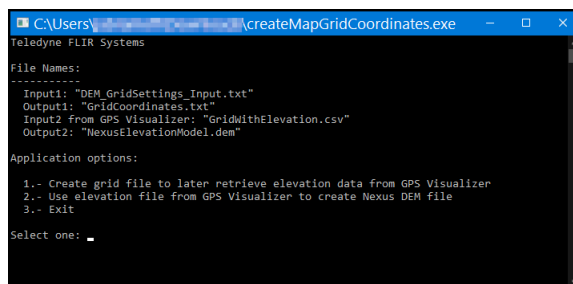

5. Type 1 and press **Enter**.

The program generates a file called **GridCoordinates.txt** with a list of the name, latitude, and longitude, for each cell in the grid.

6. Open https://www.gpsvisualizer.com/convert_input?convert_format=text.

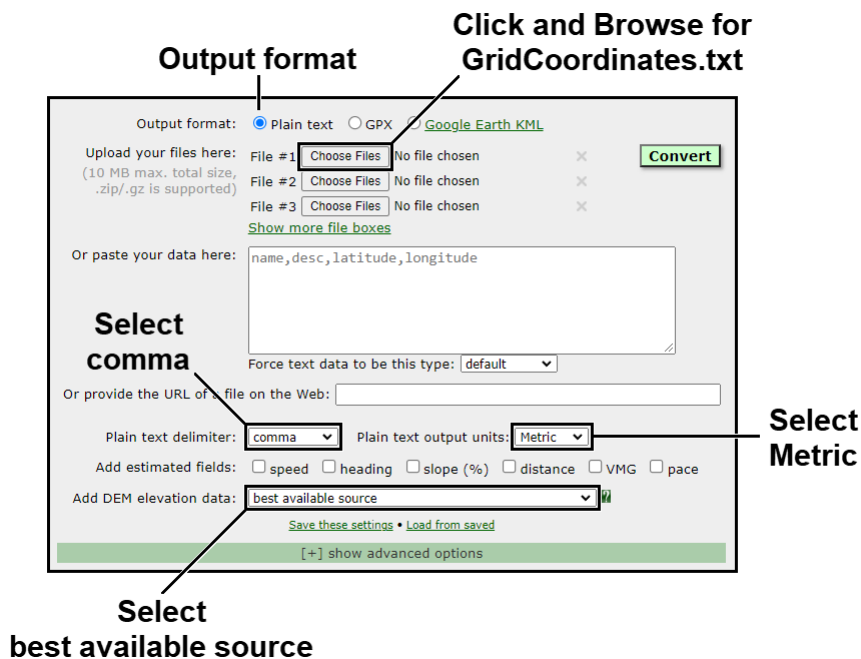

GSM Visualizer Website

7. Select:

- **Output format**—Select Plain text.
- **File #1**—Click **Choose Files**. Then, browse for and select the created **GridCoordinates.txt** file.
- **Plain text delimiter**—Select comma.
- **Plain text output units**— Select Metric.
- **Add DEM elevation data**—Select best available source.

8. Click **Convert**. The GPS Visualizer output page appears.

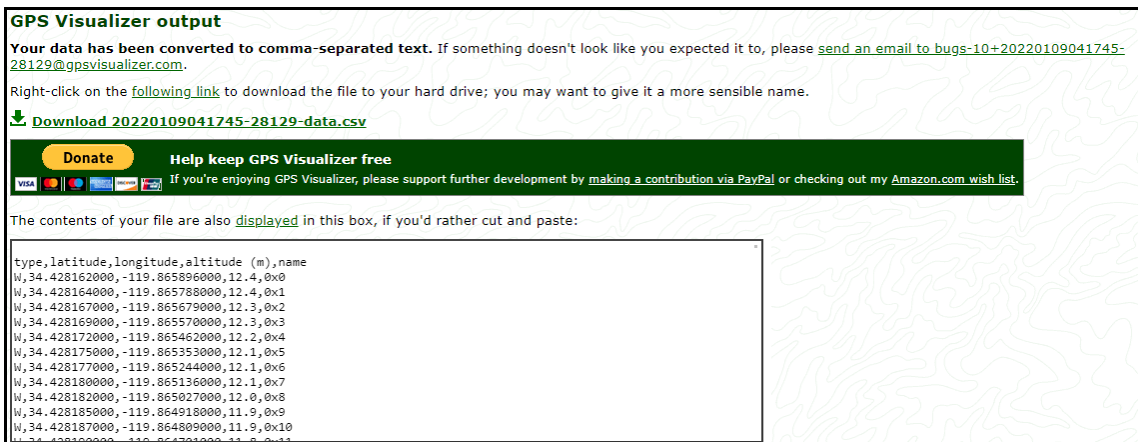

GSM Visualizer Output Page

9. Click the link to download the CSV file.

10. Move the CSV file to the extracted file folder and rename it to **GridWithElevation.csv**.

11. Run **createMapGridCoordinates.exe**.

12. Type 2 and press **Enter**.

The program generates a Nexus DEM file called **NexusElevationModel.dem**. On the [Map Page](#), you can upload this DEM file to the camera.



Teledyne FLIR
Security Solutions

Americas

27700 SW Parkway Ave.
Wilsonville, OR 97070
USA

6769 Hollister Ave
Goleta, CA 93117
USA

Support:

<https://support.flir.com/>

Document:
427-0300-00-12
Revision: 120
Date: February 2023