



Gas & Environmental Services Ltd

## Gas-Tec MK4 FID



## User Manual

M07979  
Issue 2 June 2019

[gesuk.com](http://gesuk.com)



# CONTENTS

<b>INDEX</b>	<b>PAGE</b>
1. Introduction	5
2. General description of the Gas-Tec	5
2.1 Operational Features	
2.2 Measuring Ranges	
3. Safety	6
4. Operating Instructions	
4.1 Starting Up	
4.2 Measuring Ranges and Communications	7
4.3 Use of the Instrument	
4.4 Sampling Systems	
4.5 Shut Down	8
4.6 Setting for True Ambient Level	
4.7 Oxygen Depleted Samples	
5. Maintenance	9
5.1 Daily Checks	
5.1.1 Gas Cylinder	
5.1.2 Internal Batteries	
5.1.3 Filter Assembly	
5.1.4 Probe Maintenance	
5.2. Operational Checks	10
5.2.1 Calibration	
5.2.2 Electronic Check	
5.2.3 Hydrogen Leakage Tests	
5.2.4 Removal of Instrument Cover	11
5.2.5 General	
6. Refillable Hydrogen Cylinder	11 / 12
6.1 Maintenance	
6.2 Filling with Hydrogen	

**APPENDIX** Spare and Replacement Parts List with Part Numbers.

## **ILLUSTRATIONS**

Fig. 1 The Gas-Tec and Accessories

Fig. 2 Front and Rear Views of Instrument

Fig. 3 Top View of Instrument

Fig. 4 Calibration Kit

Fig. 5 Gas-Tec Calibration Adjustment

Fig. 6 Hydrogen Filling Apparatus

47227A Filter Assembly



# 1. INTRODUCTION

The GES Gas-Tec is a self-contained lightweight, portable instrument for detecting and measuring total hydrocarbon gas concentrations down to parts per million (ppm) levels. With a fast response time of two to three seconds and good long term stability, it can be used for a wide range of applications which include:

- Leakage surveys of buried gas distribution systems.
- Detection of leaks in piping and apparatus containing hydrocarbon gases.
- Measurement of atmospheric hydrocarbon concentrations at low levels.
- Continuous 'on site' monitoring.
- Tracing migration of bio-generated gas from landfill sites or underground workings.

## 2. GENERAL DESCRIPTION OF THE INSTRUMENT

### 2.1 Operational Features

The operation of the instrument is based on the principle of 'flame ionisation.' The presence of hydrocarbons in a hydrogen flame produces an electrical (ionisation) current effect which can be detected and amplified by suitable electronic circuits.

The instrument is illustrated in figs 2 and 3 and consists of a housing (A) below which is mounted the gas cylinder (B) for the supply of hydrogen to the flame ionisation detector (FID).

At one end of the housing are various components for starting up and running the instrument. These comprise a pressure regulator and cylinder pressure gauge (C), sample air flow control (D) and flow meter (E), igniter button (F), battery charging socket (G) and calibration control under the label at (P). At the other end (Fig. 3) are the filter housing and connection for the hand probe (H), loudspeaker and socket for earphones (I), and the audio output control (O).

Visible on the top of the housing are the battery condition LED (K), combined On/Off and Range switch (L), zero adjuster (M) and gas concentration meter (N). Incorporated in the instrument is a suction pump running off the same rechargeable batteries which supply the electronic circuits. Connected to this by a flexible plastic tube is a probe handle to which alternative interchangeable probes can be attached (see section 4.4).

Available for the instrument are a special automatic battery charger, earphones and spare hydrogen cylinder, all of which can be accommodated in the fitted carrying case (see fig 1). The presence of gas is indicated by an increase in meter reading coupled with an audible signal whose pitch rises with increasing gas concentration.

The audio output level can be controlled by the knob (O). The running time of the instrument is approximately 60 hours per filling of the gas cylinder and up to 15 hours per charge for the batteries.

### 2.2 Measuring Ranges

The instrument has two ranges and in standard form is calibrated for methane in air concentrations of 0-1,000 ppm and 0-10,000 ppm (parts per million). Although the Gas-Tec is normally calibrated and scaled to methane, other Volatile Organic Compounds can be measured by applying Response Factors listed in a Conversion Chart supplied with the instrument. This chart is periodically updated as further compounds are added.

The meter scales are semi-logarithmic with graduations, which are open at lower concentrations and become progressively closer at higher readings.

The instrument can be supplied to special order with ten times normal sensitivity, i.e. ranges of 0-100 and 0-1,000 ppm with a resolution of 0.1 ppm.

### 3. SAFETY

As with any apparatus using hydrogen stored under high pressure, certain precautions are prudent. These mainly concern the handling and filling of the hydrogen cylinder and are dealt with in section 6. In addition, the detector embodies a hydrogen flame and this point should be considered when the instrument is used in situations where the gas concentrations are likely to be dangerously high e.g. in an enclosed space. When in doubt check first, with an instrument which is certified for use in hazardous atmospheres, that any gas concentrations are below the Lower Explosive Limit (LEL).

### 4. OPERATING INSTRUCTIONS

(Please refer to Figs. 2 and 3)

#### 4.1 Starting Up

Install a filled hydrogen gas cylinder underneath the instrument. NOTE:- Because the cylinder contains flammable gas, the nut has a left hand thread - finger tightness only is required, do not use tools to tighten or loosen as this may result in causing a gas leak. Fit the filter assembly and hand probe into the connector (H). (To release, push the knurled sleeve towards the instrument and pull out the filter assembly).

Attach the carry strap to the strap points on top of the instrument housing. Open the valve on the gas cylinder slowly until the pressure gauge on top of the pressure regulator indicates the gas pressure in the cylinder. Turn the switch (L) from OFF to R1 or R2 (Range 1 or 2) and check that the battery indication LED (K) is in the green sector which shows the batteries as fully charged. If the LED is in the amber sector, then the batteries are 50% charged and if the LED is red then the batteries need charging as there is only about 10% charge remaining (see section 5.1.2); it should also be possible to hear the pump running.

The pump output should be checked on the flow meter (E) and adjusted as necessary by the control (D); the correct setting is with the ball centred on the cross line. It will normally be sufficient to check this every few hours although changing to different hand probes will affect the flow slightly.

Before the flame is ignited the flame-out circuit incorporated in the instrument will operate, producing an interrupted tone in the loudspeaker. The volume of sound can be controlled by the knob (O). Rotate the zero control (M) fully clockwise. About half a minute after opening the cylinder valve the flame can be ignited by pressing the igniter button (F). Ignition will be indicated by an increase in meter reading and, after a few seconds, a change from the interrupted tone to a steady note from the loudspeaker.

If by any chance the flame is extinguished either by accident, or for example if the hydrogen supply runs out, then the interrupted tone will be resumed.

The correct working condition can be established by rotating the zero control (M) counter clockwise, thus "backing off" the standing signal until the meter returns to zero and the loudspeaker output drops to a slow ticking sound. This should be carried out in nominally 'clean' air.

## 4.2 Measuring Ranges and Communications

**Meter Scales:** In order to cover as wide a range as possible without too many scale changes, a semi-logarithmic scale for the meter has been chosen. Thus Range 1 (R1) is scaled 0-10-100-1,000 ppm while Range 2 (R2) is 10 times this i.e. 0-100-1,000-10,000 ppm. Inspection of the meter will show that the first third of the scale (0-10 or 0-100 ppm, depending on range) is linear, i.e. evenly divided, while the second and third decades are logarithmic, i.e. the scale is progressively compressed at higher gas concentrations.

**Communications Socket:** Both measuring ranges provide a 0-2 Volt output for external use. The socket (G) (Fig. 2) accepts the standard battery charger connector, or will allow the connection of an external data logging or monitoring device such as a volt meter or chart recorder. The socket is a standard 8 pin DIN with the pins having the following functions:

- Pin 1. Internal battery; positive (+7 V).
- Pin 2. 0-2 V Linear output.
- Pin 3. Internal battery; negative (-5 V).
- Pin 4. Earth (0 V).
- Pin 5. Earth (0 V).
- Pin 6. Range B Logic
- Pin 7. Range C Logic
- Pin 8. 0-2 V Lin/Log output.

Note: Pins 1 and 3 are used for charging the internal batteries, NEITHER side is at earth potential.

## 4.3 Use of the Instrument

The instrument is designed to be carried over the shoulder (or alternatively on the chest by shortening the straps).

If working conditions require (e.g. in very noisy environments or for the sake of privacy) the optional earphone may be used by plugging into the socket over the loud speaker (I).

## 4.4 Sampling Systems

Two sampling systems are available:

1. An insulated probe handle system for gas leak monitoring.
2. Telescopic Probe with PTFE tubing for monitoring VOCs.

System 1: A variety of probe ends (illustrated in Fig. 1) can be plugged into the insulated probe handle as follows:

- Standard probe (L) with a perforated transverse end, which is particularly useful for walking ground level, surveys. This probe is normally supplied as standard, complete with two skids (K) which maintain a small clearance between the probe and the ground.
- A straight probe (J) for pinpointing leaks from pipe fittings, inside ducts or through ventilating bricks or other apertures, or general atmospheric sampling.
- A 'roller' probe (N) - primarily for smooth surfaces such as pavements; the rolling seals shield the pickup tube from excessive wind effects.
- A cup probe (I) - this attachment fits on the end of the straight probe and is used for point by point checks. The inverted rubber cup protects the probe end in windy conditions.

Note that there is a small cavity at the junction of the probe handle and probe end assembly thus providing a trap for a limited amount of water which may be picked up in wet conditions. The joint should be opened periodically and any water shaken out and to avoid water passing into the instrument.

System 2: The telescopic probe terminates with a straight length of 5 mm diameter stainless steel tubing to which a variety of probe ends can be fitted.

- A Standard 'Tee' probe with a perforated transverse end, which is particularly useful for walking ground level surveys.
- A cup probe (I) is used for point by point checks. The inverted rubber cup protects the probe end in windy conditions.
- Straight probe extensions for collecting bore hole samples.

#### **4.5 Shut Down**

Switch to OFF and close the cylinder valve. DO NOT use excessive force as the valve is designed to be completely leak free with finger tightness only and will only be damaged if force is used.

#### **4.6 Setting for True Ambient Level**

All ambient air has a background level of hydrocarbons. Even the cleanest atmospheric air has about 2 parts per million by volume. When surveying for moderate to high levels, or when surveying for changes of level, setting the instrument zero to the background level is acceptable.

When monitoring for low levels and particularly when checking their variations over a series of surveys, setting the Gas-Tec to a true zero is recommended as a standard practice and can be carried out as follows:

- After ignition allow the Gas-Tec to stabilise by running for 10-15 minutes.
- Partially fill a clean sample bag with hydrocarbon free air from a pressurised container.
- Set the instrument scale reading to about 20 ppm on Range 1 using the zero control knob.
- Insert the end of the hand probe into the bag, wait for the instrument scale reading to stabilise, then set the scale reading to zero.
- Check that the reading remains at zero as the sample bag deflates.
- Remove the hand probe from the sample bag BEFORE it deflates completely.

#### **4.7 Oxygen Depleted Samples**

If it is suspected that the oxygen content of the sample is less than 90% of ambient air, then the sample should be diluted with ambient air in a controlled manner before it enters the Gas-Tec.

This can most conveniently be done by use of the GES Range Extender, which connects in place of the hand probe. By providing 90% ambient air and 10% sample the Gas-Tec will accurately monitor samples, even if totally devoid of oxygen.



## 5. MAINTENANCE

### 5.1 Daily Checks

#### 5.1.1 Gas Cylinder

Maintain sufficient gas pressure for the survey time expected. A full gas cylinder (150 bar, 2150 psi) should last for approximately 60 hours and thus the average hourly pressure drop is around 2.5 bar (35 psi). Note however that the pressure should not be allowed to drop much below 5 bar for reasons explained in section 6 which details the procedure for filling empty hydrogen cylinders.

#### 5.1.2 Internal Batteries

The voltage under load should be checked on the meter (K) (Fig. 3). Fully charged batteries should last approximately 15 hours: Recharge if the LED is red with the instrument switched on. To do this insert the battery charger plug into the socket (G) and plug into a suitable mains supply. (The charger is normally delivered set to 240 V 50 Hz; this can be changed externally to 110 V). The red light on the charger will be illuminated initially but is likely to go out when the charging process is nearly complete. The charging can be continued after this point with no danger of overcharging.

#### **IMPORTANT:**

(a) Do not leave the battery charger plugged into the instrument with the mains supply disconnected or switched off; it will slowly discharge the batteries.

(b) If the instrument is left unused or in storage, the batteries should be charged every month to keep them in good working order.

#### 5.1.3 Filter Assembly (FIL99016)

The filter assembly houses a filter backing disc, a 25 mm diameter hydrophobic filter element, an 'O' ring, and a 27 mm diameter paper pre-filter element. The paper pre-filter should be inspected regularly and replaced when necessary. This will protect the hydrophobic filter from coarse contamination and extend its life.

When fitting this filter, the hydrophobic surface should contact the 'O' ring (ORG99005) and the fibrous surface (stamped 'RE') should be placed face down against the backing disc (FIL99021). When assembled in this manner, if water enters the filter assembly it will be prevented from passing through the hydrophobic surface. Discarding the pre-filter, shaking or lightly blowing the hydrophobic surface and reassembling the unit with a new pre-filter should allow continued operation. Make sure all water is removed from the probe and tube assemblies before re-using.

NOTE: Instruments should not be run without the filter assembly FIL99016

#### 5.1.4 Probe Maintenance

The water trap cavity at the bottom of the insulated probe handle should be cleaned out with a clean rag or tissue (do not use volatile solvents); clean also the mating tapered joint.

The probes should be kept clean, with any small holes unobstructed. Pricking with a pin and reverse blowing should be adequate.

The roller probe should have freely running rollers. To dismantle, remove the two knurled screws from the ends, drop out the main housing from the yoke and pull out the lateral bars, which carry the roller pivots at each end of the housing. The rollers will then be removable for cleaning.

## 5.2 Operational Checks

### 5.2.1. Calibration

Overall checking and calibration of the instrument can be made with gas in air mixtures of known concentration and a kit is available which enables the user to do this at one point on the scale. The kit consists of the following items (Fig. 4):

Pressured canister of sample gas (normally 200 ppm methane in air).

Combined flow regulator valve and indicator with sample tube.

Labels marked 'CALIBRATED'.

Instructions.

**Note:** The canisters contain a maximum of 10 minutes continuous use when the flow is adjusted correctly, and therefore should be used with care to conserve gas.

#### Instructions

**Assembly of Kit:** Take the flow regulator valve/indicator assembly and make sure the valve is closed by turning the knob fully clockwise. Attach the outlet tube to the flow meter and screw the brass valve onto the threaded outlet of the canister after removing the white protector cap.

Stand the canister on its base so that the flow meter is vertical and insert the end of the Gas-Tec hand probe fully into the outlet tube. Start up the Gas-Tec and remove the existing 'CALIBRATED' label.

**Calibration Procedure:** In a clean air environment, check the Gas-Tec sample flow and zero, then very carefully open up the valve on the canister until the ball in the flow indicator is opposite the central mark on the tube.

The Gas-Tec should rapidly indicate a concentration equal to that shown on the canister. If necessary, adjust the calibration control with a small screwdriver (Fig. 5) until the meter reads correctly. Turn off the gas supply and seal the hole in front of the calibration control with a new, updated 'CALIBRATED' label.

Turn off the Gas-Tec and disassemble the calibration kit.

**Frequency of Calibration:** This depends on the conditions and amount of use, but as a guide it is suggested that every six months is appropriate. If a record is kept of the calibration dates and any errors observed, this will help in deciding whether this period is too long or too short.

### 5.2.2. Electronic Check

If the unit appears faulty, either from the calibration check results above or from any other observations, the defect can be localised by means of the electronic test device. This simulates the signal given by a mixture of hydrocarbon in air and plugs into the co-axial socket to which the flame detector is normally connected.

### 5.2.3. Hydrogen Leakage Tests

It is important for safety and other reasons that the instrument should be free from a hydrogen leaks. This can readily be checked by brushing a solution of liquid detergent onto the various pipe connections, cylinder valve spindle etc. Leaks should be dealt with by tightening, replacement of seals etc., as appropriate. It is advisable to smear O-rings with silicone grease. (Do not use greases based on mineral oils).

#### **5.2.4. Removal of Instrument Cover**

If for any reason the instrument cover has to be removed, proceed as follows:

First remove the two knobs on the top of the instrument by prising off the grey plastic top caps with a penknife or similar. While holding the knobs, release the central nuts with an 8 mm A/F box spanner to free the collets. After taking out the two Posi-drive screws from the centre of the two sling attachment brackets, slide the cover vertically off the chassis of the instrument

To replace the cover, first inspect that the foam rubber sealing strips are in good condition and in place. Slide the cover squarely down onto the chassis, pressing in the sides slightly to engage the retaining lips on each side. Finally replace the two Posi-drive screws and the knobs, ensuring that the pointer on the range switch is correctly orientated.

#### **5.2.5 General**

Please note that as the instrument is very sensitive to hydrocarbons, the use of solvents, greases etc, based on hydrocarbons when cleaning and servicing should be avoided. Such solvents can contaminate the instrument for a considerable time.

### **6. REFILLABLE HYDROGEN CYLINDER**

#### **6.1. Maintenance**

The hydrogen cylinder and associated shut-off valve must be maintained completely leak free at all times for reasons of safety and economy and should ideally be inspected at regular intervals when filled with hydrogen up to the maximum working pressure as stamped on the neck or end of the cylinder. If the valve is leaking it can be serviced with spares available from the manufacturer. Please note that the quickest way to damage the valve is by using excessive force to close it. Finger tightness only is necessary.

The hydrogen cylinder must be re-certified every 5 years.

Note: Hydrogen is highly flammable - treat it with respect and keep gas cylinders away from heat, naked flames and other sources of ignition.

#### **6.2. Filling with Hydrogen**

As mentioned in Section 5.1.1, it is important not to allow the gas cylinder pressure to fall to atmospheric, thus allowing air to enter; cylinders should be recharged or replaced with a spare when the gauge drops to below 5 bar. When filling a cylinder, which already has air in it, there is a danger of: (a) an explosion and (b) dilution of the hydrogen with air which can affect the operation of the instrument. The cylinders should be refilled with normal commercial hydrogen generally obtainable from compressed gas suppliers. If local depots are willing to undertake this a suitable nipple and nut etc, can be supplied to facilitate connection. For operators who wish to refill their own cylinders from bulk supplies at high pressure, a Hydrogen Filling Panel is available, as shown in Fig. 6. This incorporates the necessary cylinder holding clamp and connector, control valves and pressure gauges. It is designed to limit the rate of filling, an important safety factor.

Full installation instructions and safety procedures are given in the manual supplied with each apparatus but abbreviated instructions are as follows.

## **HYDROGEN CYLINDER FILLING PROCEDURE**

(for full instructions see Operating Manual)

1. Close all valves, connect gas supply cylinder (left hand thread, finger tight only) and secure clamp.
2. Open gas cylinder valve and check that a positive pressure exists; if so, close the valve.

If there is no pressure , do not proceed, refer to the manual and close the valve.

3. Open vent and inlet valves.
4. Open supply cylinder valve cautiously and allow hydrogen to vent, purging the system.
5. Close vent and open gas cylinder valve, pressure will rise slowly.
6. When pressure in gas cylinder reaches the maximum working pressure\*, close inlet valve, supply cylinder valve and gas cylinder valve.
7. Open vent valve slowly to release pressure in manifold.
8. Remove gas cylinder.

**\*IMPORTANT:** Do not exceed the maximum working pressure as marked on cylinder.

## APPENDIX

### GAS-TEC SPARES AND REPLACEMENT PARTS LIST WITH PART NUMBERS

Please always quote part number and serial number of GAS-TEC when ordering.

<b>Part Number</b>	<b>Description</b>
FIT99034	SKID
PRB99010	ROLLER PROBE ATTACHMENT
FIL99012	PAPER FILTERS BOX OF 400
CAS64006	CARRYING CASE AND FOAM INSERT
PRB64002	STANDARD PROBE ASSEMBLY
STP64001	CARRYING STRAP
CHG64001	BATTERY CHARGER
PRB99016	ROLLER ASSEMBLY (RUBBER SLEEVE)
PRB64001	STRAIGHT PROBE (FOR INSULATED PROBE HANDLE)
PRB99007	PROBE CUP
OPT99001	CALIBRATION GAS KIT
CYL64001	REFILLABLE HYDROGEN CYLINDER COMPLETE
CYL99009	SPARE CYLINDER FOR CALIBRATION GAS KIT
FIL99016	FILTER ASSEMBLY
FIL99013	HYDROPHOBIC FILTERS PACKET OF FIVE
HND64001	INSULATED PROBE HANDLE ASSEMBLY
PRB99011	TELESCOPIC PROBE KIT (INCLUDES TEE PROBE)
PRB99014	SPARE TEE PROBE
RAN99001	RANGE EXTENDER
PRB99006	BORE HOLE GAS PROBE ASSEMBLY
PRB99005	STRAIGHT PROBE (FOR TELESCOPIC PROBE)
EAR99001	ACOUSTIC HEADPHONES

**Contact Gas & Environmental Services Ltd**  
**for details of hydrogen filling services that can be offered.**  
**(Refillable cylinders only)**

Other part numbers on application. For users who service their own instruments a more extensive list of spare parts appears in the Service Manual. If you have any queries please contact us.



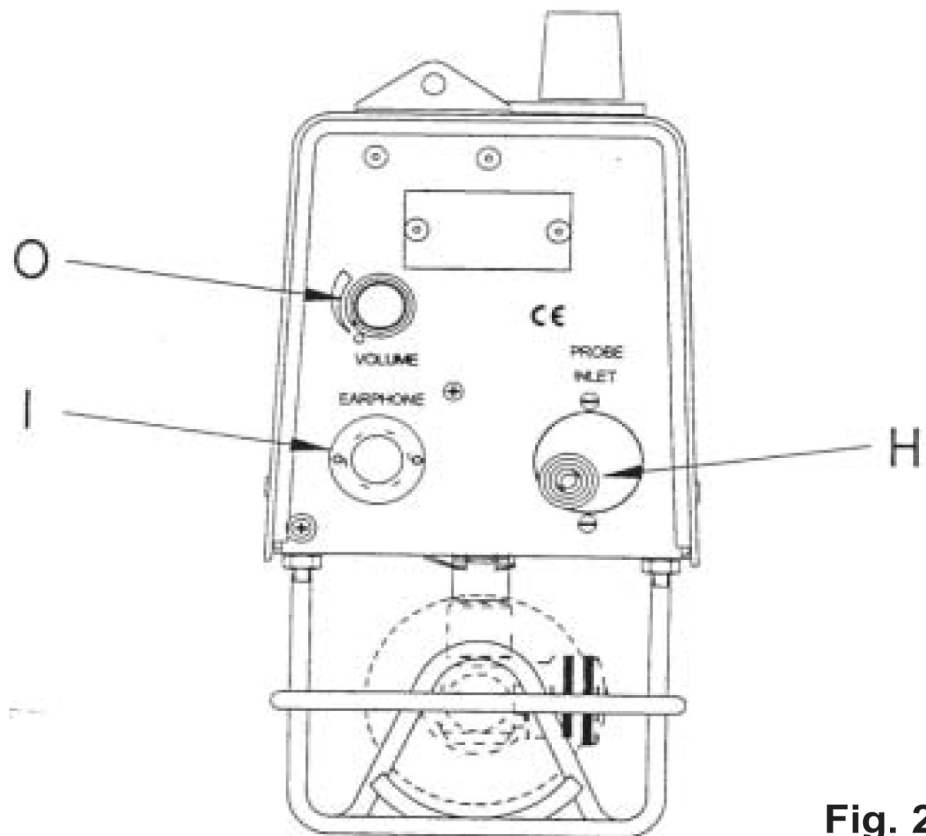
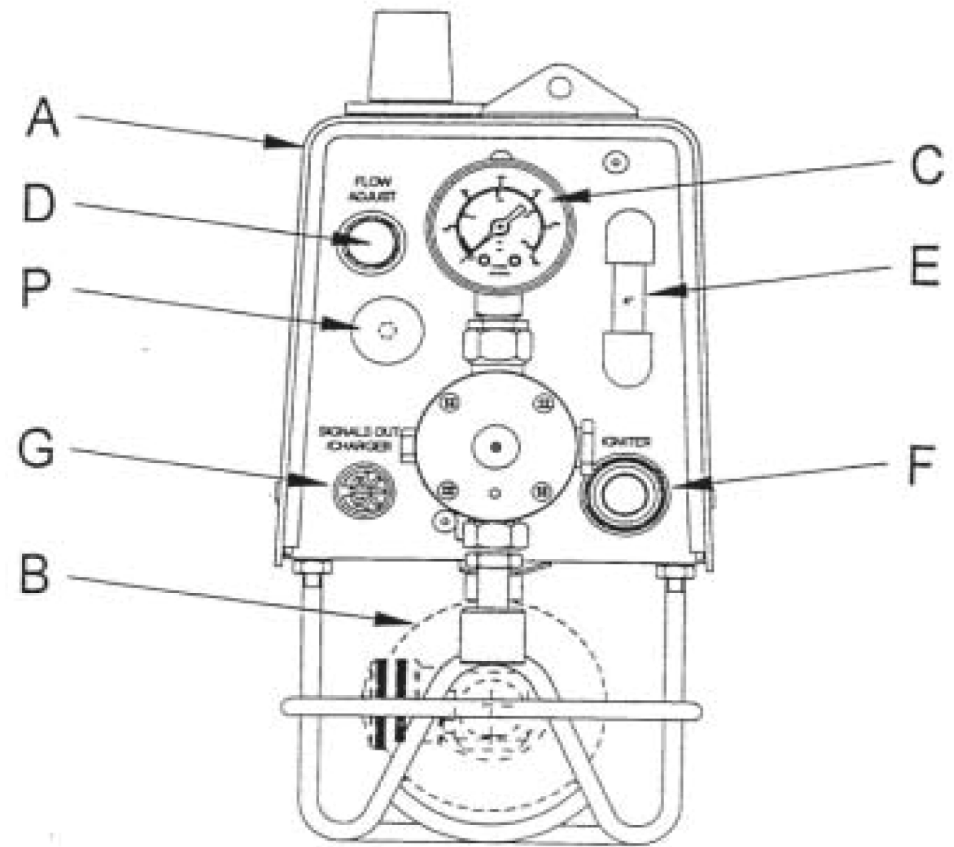

Fig. 2

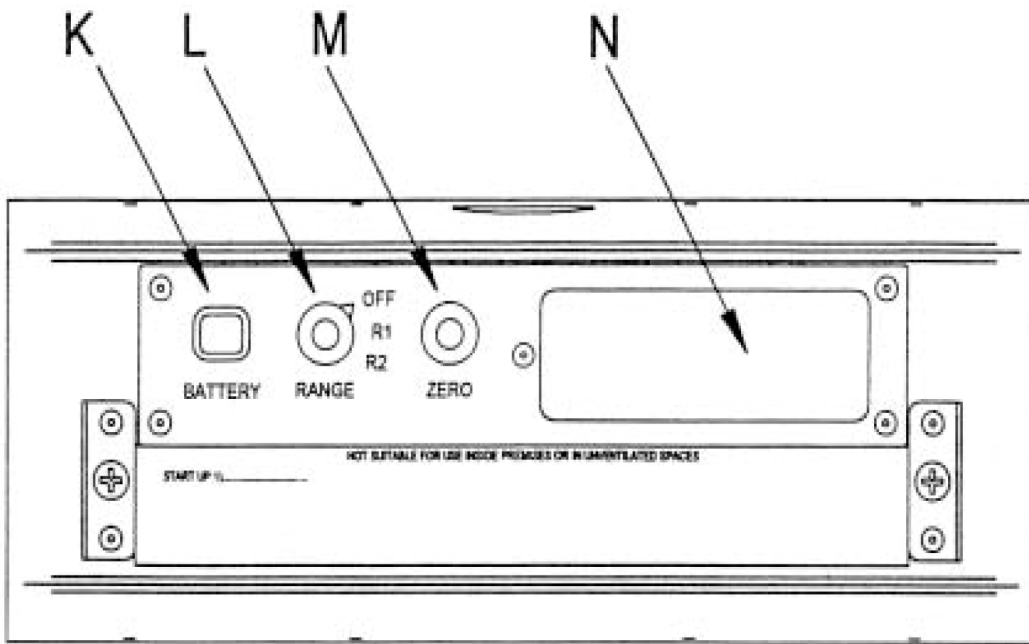
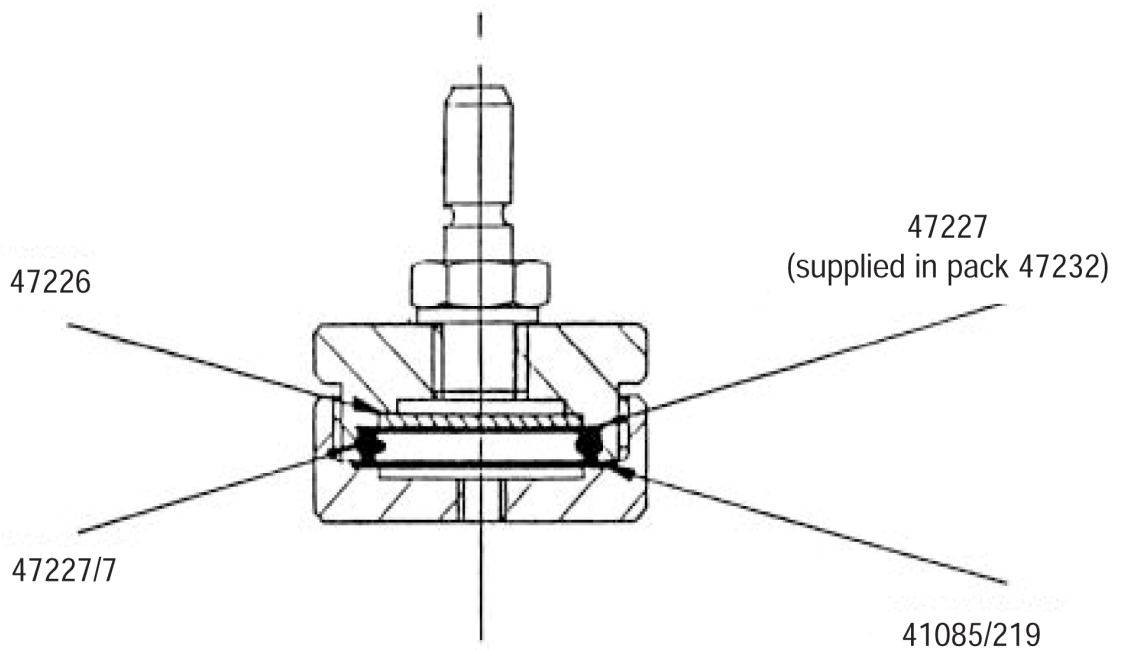

Fig. 3







**Fig. 4**



**Fig. 6**



**Fig. 5**





**Gas & Environmental Services Ltd**  
Units 1 & 3 Little Ridge Industrial Estate  
Welwyn Garden City  
Hertfordshire, AL7 2BH, UK  
Tel: +44 (0) 1707 373751  
Fax: +44 (0) 1707 373752  
Email: sales@gesuk.com

[www.gesuk.com](http://www.gesuk.com)