User & Installation Guide

G4500 / G3500 BlackBox Portable Power Quality Analyzer



Table of Contents

Introduction - System Overview.....	8
Warranty	10
Acronyms.....	11
Product Selection Guide.....	14
Preparation - Safety Precautions	18
What You'll Need.....	20
Unpacking Components & Accessories	21
The G4500 BLACKBOX Portable PQ Analyzer	27
The G3500 BLACKBOX Portable PQ Analyzer	30
Installation	33
Unit Powering.....	34
G4500 & G3500 Unit Wiring	37
Grounding	42
Plug & Play - Voltage & Current Probes	43
Establish 1st Time Connection	47
G4500 / G3500 Unit Access.....	50
About Quick Unit Configuration	54
Quick Unit Configuration.....	55
Voltage & Frequency Configurations	57
Currents.....	60
About Verifying Measurement Readings	65
Access the Measurement Summary	65
Verify Voltage & Current Readings	67
Verify Power Readings	69

Enabling PQZIP Recording	70
About Monitoring Real Time Data	72
Voltage & Current Measurements	75
Average.....	80
Power	85
Temperature.....	88
Phasors	90
Waveforms	95
Voltage Flickering	101
Pinst Waveform.....	104
Minimum / Maximum Flickering.....	106
Voltage & Current Harmonics	109
PQ Harmonics.....	115
Spectrum	120
Harmonics Table.....	125
Voltage & Current, Min & Max Harmonics Table.....	129
PQ Min & Maximum Harmonics.....	132
About Monitoring Power Quality	135
PQ Compliance Summary.....	136
Compliance Information.....	140
Compliance Chart	143
Events	145
PQZIP Recording - Principle	147
Default Settings	149
PQZIP Configuration - About PQZIP Recording	150
Enabling / Disabling PQZIP	155

FIFO	157
Fixed Quality vs. Fixed Ratio	158
File Capacity	161
FFT Mode.....	163
Capture DC Measurements.....	165
Erase All PQZIP Data.....	166
Energy - About	168
Consumption & Demand.....	168
Detailed Information.....	170
Measurement Status.....	172
Instrument Settings - About	174
Device Configurations – Overview Device Setup	174
Device Info - Unit Configuration	176
Product Info	179
Power Status.....	180
PoE Output.....	181
Alarms & Other Indications.....	182
Time Settings - Time Synchronization.....	185
Time Setup.....	187
Network Time	188
Daylight Saving.....	190
Voltage & Frequency.....	191
Power Configuration.....	192
Potential Transformer.....	194
Smooth Filtering.....	195
Voltage Polarity.....	196

Define Nominal Values	197
Current	199
Current Probes Info.....	202
Custom DC Probes Info	205
Non-Measured Currents	208
Communication - Configuration	208
Security.....	211
Network - About Network Setup	213
Wi-Fi Connectivity (G4500 Only).....	215
WAN Internet Accessibility (G4500 Only).....	223
LAN 1 (G4500 Only).....	225
LAN 2	226
Outer Access	229
Port Setup	230
Status Summaries	232
Serial Ports	234
RS-485 / RS-422	236
PPP Configuration	237
PPP Status	238
Modem Configuration.....	239
About Power Quality Compliance	240
Power Quality Compliance Configuration.....	241
User Custom Compliance - User Defined Pages	243
User Defined Page 1.....	245
User Defined Page 2.....	250
User Defined Page 3.....	254

About Advanced Settings.....	257
System Log.....	259
GPS Configuration	262
Custom Events - Creating Custom Events	264
Events List.....	268
Create Event Conditions.....	270
Single Type Conditions.....	272
Multiple Type Conditions.....	276
E-Mail Alerts.....	278
Reports - About Reports.....	282
Energy Mode	284
Parameter Mode	285
Energy Meter	286
Display Setup	289
Upgrade BLACKBOX Software - About Firmware Upgrade	292
Upgrade the FW Using FTP	295
Local FW Upgrade	297
Other Connections & Settings - About	299
The I/O Ports of the Portable BLACKBOX - Overview.....	299
IO Port Connections - About Connecting the IO Ports.....	300
Connect the Digital Input.....	301
Connect the Relay.....	303
IO Port Setup - About Monitoring & Setting Up Your IO Ports	305
Digital Input - Setup	306
Digital In Status	310
Relay - Setup	312

Event Signal.....	314
Energy Signal.....	317
Alarm Signal.....	320
Relay Status.....	322
Communication Ports - About Connecting The Ports.....	323
Connect The LAN Ports.....	324
Serial Port Connections.....	328
Battery Replacement.....	332
Remove The Malfunctioned Battery.....	333
Replace The New Battery.....	335
Attach The PT100 Temperature Connection (Optional).....	336
Reset Your Portable BLACKBOX.....	337
Elspec Search Utility - About.....	338
Obtain Elspec's Search Utility.....	339
Use the Elspec's Search Utility.....	340
G4500/G3500 Unit Access.....	342
New Device Indication.....	346
Limitations of Elspec's Search Utility.....	347
Specifications.....	348
Physical Specifications & Dimensions of the Portable BLACKBOX.....	356

Introduction - System Overview

Tailored for PQ Analysis at any location, the Portable BLACKBOX has been especially designed to address the needs of **Site Engineers, Electrical Consultants & Utilities:**

- **No Missed Events**
- **Quick & Simple Setup**
- **Remote Connectivity**
- **Plug & Play**

Empowered by the patented **PQZIP compression** technology, the G4500/G3500 can store up to a thousand times more than other typical file formats. The **PQZIP allows the Portable BLACKBOX** to continuously record & store all electrical waveforms, all the time, for extended periods, with no gaps in the data. Capture everything, Trends, Volts/Amps/Hz, Events, Harmonics, THD, Flicker, Power & Energy to get down to the root cause of all your Power Quality issues. The Portable BLACKBOX fully complies with IEC 61000-4-30 Class A standards for: aggregations, time clock uncertainty, flagging & transient influence quantities.

The advanced **PQSCADA & Investigator Enterprise Analysis** software enables the operator to detect, view, control, analyze & isolate the minutest PQ anomaly for the diagnosis & effective maintenance of equipment. It simplifies troubleshooting & time-synchronized data recorded by any number of BLACKBOX devices, can be compared within a particular site &/or across many sites.

The embedded **Website** serves as the main user-interface with the unit, providing enhanced management, unit configuration & real-time monitoring of all parameters.

The figure below provides a graphical outline of the BLACKBOX Portable System:

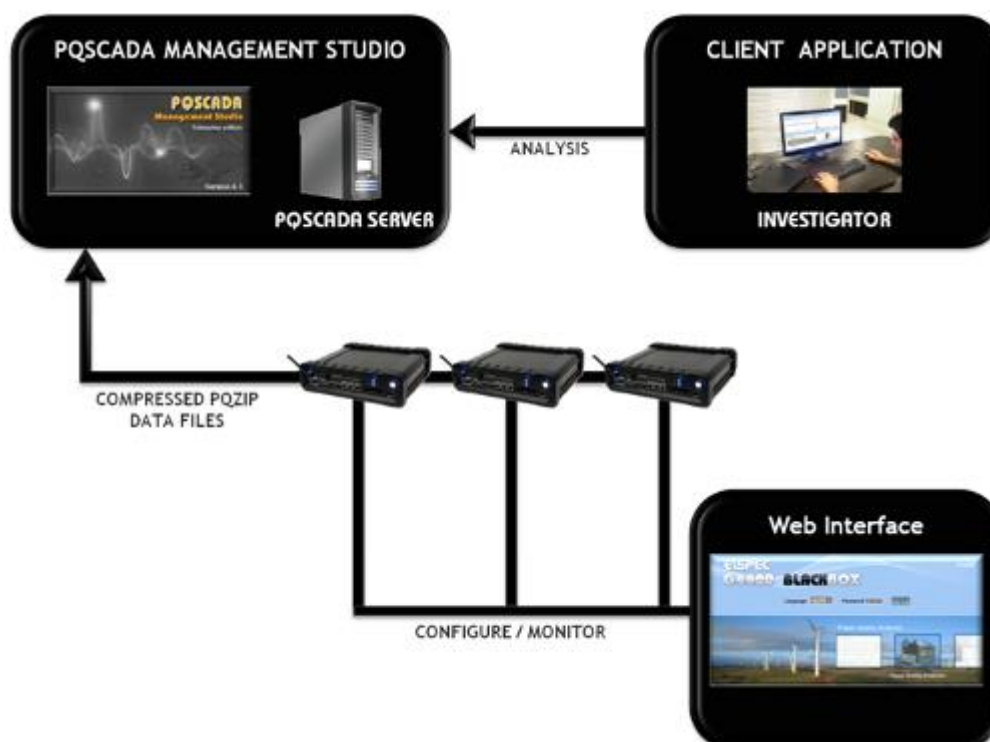

EVERYTHING YOU NEED IN A PORTABLE POWER QUALITY SOLUTION & MORE

- 1 X Custom Clamp 3-Flexible Current Probes
- 5 X Voltage Leads (Automatically Detected)
- 2 X DC Voltage Cords (G4500)
- Durable Carrying Case
- Rechargeable Power Supply (2 Hours Standby)
- Wireless Network (G4500)
- PQSCADA / Investigator Software CD
- Mobile Analysis Lab



SEE ALSO:

- [Warranty](#)
- [Acronyms](#)
- [Product Selection Guide](#)

Warranty

Each Elspec product is under warranty to be free from defects in material and workmanship under normal use and service. The warranty period is for one year and commences on the date of shipment. Parts, product repairs, and services are under warranty for 90 days. This warranty extends only to the original buyer or end-user customer and it does not apply to fuses, disposable batteries, or to any product which, in Elspec's opinion, has been misused, altered, neglected, contaminated, or damaged by accident or abnormal conditions in the operation or handling of the product. Elspec guarantees that the software will operate substantially in accordance with its functional specifications for 90 days and that it has been properly recorded on non-defective media. Elspec does not guarantee that the software will be error free and operate without interruption.

Elspec authorized re-sellers shall extend this warranty on new and unused products to end-user customers only, but do not have authority to extend a greater or different warranty on behalf of Elspec. Warranty support is available only if the product is purchased through an Elspec authorized sales outlet or Buyer has paid the applicable international price. Elspec reserves the right to invoice the Buyer for any importation costs for the repair/replacement of parts when the product purchased in one country is submitted for repair in another country.

Elspec's warranty obligation is limited, at Elspec's option, to refund of the purchase price, free of charge repair, or replacement of a defective product which is returned to Elspec within the warranty period. For warranty service, contact Elspec directly to obtain a return-authorization. On receipt of the authorization, return the product to Elspec with a description of the problem, including prepaid postage and insurance (FOB destination). Elspec assumes no risk for damage in transit. Following warranty repair, the product will be returned to the Buyer, transportation prepaid (FOB destination). If Elspec determines that the failure was caused by neglect, misuse, contamination, alteration, accident, or abnormal condition of operation or handling, including overvoltage failures caused by use outside the product's specified rating, or normal wear and tear of mechanical components, Elspec will provide an estimate of repair costs and obtain authorization before commencing work. Following repair, the product will be returned to the Buyer, transportation prepaid, and the Buyer will be billed for the repair and return postage transportation charges (FOB Shipping Point).

This warranty is the Buyer's sole and exclusive remedy and is in lieu of all other warranties, express or implied, including but not limited to any implied warranty of merchantability or fitness for a particular purpose. Elspec shall not be liable for any special, indirect, incidental, or consequential damages or losses, including loss of data arising from any cause or theory. Since some countries or states do not allow limitation of the term of an implied warranty, or exclusion or limitation of incidental or consequential damages, the limitations and exclusions of this warranty may not apply to every buyer. If any provision of this Warranty is held invalid or unenforceable by a court or other decision-maker of competent jurisdiction, such holding will not affect the validity or enforceability of any other provision.

NOTICE REGARDING PROPRIETARY RIGHTS

This publication contains information proprietary to Elspec. By accepting & using this manual, you agree that the information contained herein will be used solely for the purpose of operating equipment developed & manufactured by Elspec.

SEE ALSO:

- [System Overview](#)
- [Acronyms](#)
- [Product Selection Guide](#)

Acronyms

The following acronyms are being used within this document:

ACRONYM	DEFINITION
PQ	Power Quality
V	Voltage
I	Current
AC	Alternating Current
DC	Direct Current
F	Frequency
V_N	Voltage Neutral
I_N	Current Neutral
A	Ampere
CT	Current Transformer
PF	Power Factor
PT100	Platinum Resistance Thermometers
PU	Per Unit
PT	Potential Transformer (transformation ratio in both magnitude and phase)
CT	Current Transformer
HV	High Voltage
MV	Medium Voltage
LV	Low Voltage
THD	Total Harmonic Distortion
ADC	Analog to Digital Converter
SSL	Secure Sockets Layer
GPS	Global Positioning System

ACRONYM	DEFINITION
UTC	Coordinated Universal Time
LAN	Local Area Network
WAN	Wide Area Network
ADSL	Asymmetric Digital Subscriber Line
CF	Compact Flash
OLP	OLE for Process Control (set of connectivity standards for industrial automation)
OPC	Open Connectivity (formerly OLE for Process Control)
TCP	Transport Control Protocol
FTP	File Transfer Protocol
DHCP	Dynamic Host Configuration Protocol
DNP3	Distributed Network Protocol
PPP	Point to Point Protocol
PAP	Password Authentication Protocol
CHAP	Challenge Handshake Authentication Protocol
UART	Universal Asynchronous Receiver Transmitter
ISP	Internet Service Provider
INIT	Initialization (INIT String used in Modem)
AT	A command string should start with "AT" or "at", except for the commands "A/" and "+++". At or aT are invalid
PST	Value measured over x period that characterizes the likelihood that the voltage fluctuations would result in perceptible light flicker
THD	Total Harmonic Distortion
TDD	Total Demand Distortion
Ampl	Amplitude
FIFO	First In First Out

ACRONYM	DEFINITION
FFT	Fast Fourier Transform
csv	Comma Separated Values

ACRONYM	DEFINITION
ELSPEC G4500/G3500 BLACKBOX DEVICE & ACCESSORIES	
BB	BLACKBOX
G4500 / G3500	BLACKBOX Portable Power Quality Analyzers
G4150	Mobile Analysis Lab
PQA	Power Quality Analyzer
R/O	Perform Read Only Functions Within the BLACKBOX Interface
R/W	Perform Read & Write Functions Within the BLACKBOX Interface
RTC	BLACKBOX Internal Real Time Clock
DSP	Digital Signal Processing Module (Located Internally)
PQZIP	Power Quality Data Compression & Archive File Format
PQSCADA	Power Quality Supervisory Control and Data Acquisition
S/N	Serial Number
HW	Hardware
SW	Software
FW	Firmware - BLACKBOX Software

See also:

- [System Overview](#)
- [Warranty](#)
- [Product Selection Guide](#)

Product Selection Guide

The product selection guide will assist you in choosing the optimal Portable PQ Analyzer that will suit your needs & requirements. The BLACKBOX device series includes 2 products, namely the G4500 & G3500. They are mainly differentiated by their measurement capabilities, storage capacity, PQ analysis & communication ports.

CAPABILITIES	PRODUCT SERIES	
	G4500	G3500
REAL-TIME MEASUREMENTS		
Voltage Sampling Rate, Maximum Samples/Cycle	1024	512
Voltage/Current - Per Phase, Average, Unbalanced	√	√
Power: Real, Reactive, Apparent, Power Factor, Frequency	√	√
Energy: Bidirectional, Total, Import, Export, Net	√	√
Demand: Block	√	√
Voltage Harmonics (Individual, Even, Odd, Total) Up to-	511 TH	255 TH
Type of Analog to Digital Converter	16/20 ¹ Bit	16/20 ¹ Bit
Measurement During Overloading (From Nominal)	x10	x10
DATA & WAVEFORMS LOGS		
Cycle-By-Cycle PQZIP Recording	√	√
Event Logs	√	√
Continuous Waveform Recording	√	√
Min/Max Logs For Any Parameter	√	√

CAPABILITIES	PRODUCT SERIES	
	G4500	G3500
TIME STAMPS, RESOLUTION (MICROSECONDS)		
With Ethernet Synchronization	50	50
With GPS Synchronization	1	1
STORAGE CAPACITY		
Internal Memory	32 GB 32TB ²	256 MB 256 GB ²
POWER QUALITY ANALYSIS		
Transient Detection, Microseconds (50Hz/60Hz)	19.5/16.3 μ s	39/32.5 μ s
Sag/Swell Monitoring	√	√
Unbalance Components: Zero, Negative, Positive	√	√
Flicker (IEC 61000-4-15)	√	√
Fast Flickering	√	√
Compliance Testing To EN50160	√	√
EN50160 Timestamps	√	√
Configurable for IEEE519-1992, IEEE159 (SEMI)	√	√
Time Stamps Of Above	√	√
Inter-Harmonics	√	√
POWER SUPPLY		
Power Over Ethernet (PoE- In) ³	According to 802.3af	
Operating Range	100-260VAC: 50/60Hz 100-300VDC	
Auxiliary AC Supply	48VDC	
Battery Backup	2 Hours	
E-MAIL NOTIFICATIONS		
SMTP Client	√	√

CAPABILITIES		PRODUCT SERIES	
		G4500	G3500
COMMUNICATION			
CONTROL			
Web Server	Comprehensive web server for local & remote real-time monitoring & control		
FTP Server	Standard protocol for main storage memory		
Channels	1 x Change Over		
Max Voltage	277 VAC		
Max Current	5A / 250VAC 10A / 110VAC 5A / 30VDC		
Max Reaction time	10ms		
Max Drop-out time	4ms		
Output Resistance	50MΩ		
¹ Effective Bits ² Equivalent Memory Needed Without Pqzip Compression ³ G4500 Unit Only DISCLAIMER: OUTLINED CAPABILITIES SUBJECT TO CHANGE WITHOUT PRIOR NOTICE			
PORTS			
Ethernet Ports	2 LAN & 1 WAN (Integrated Router, NAT & Firewall)	1 LAN	
RS-232, RS-485 Ports	1	1	
Wi-Fi Communications (802.11g)	1 (With Integrated Antenna)	—	
LAN 1			
Communication Protocols	TELNET, OPC, SMTP Client		
Power Over Ethernet (PoE- In) ³	According to 802.3af		
LAN 2			
Communication Protocols	Modbus TCP, Modbus RTU, OPC, DNP3 & SMTP Client		

MULTI IO	
DIGITAL INPUTS	
Channels	4
Sampling	800 Hz @ 50Hz (16 spc) 960 Hz @ 60Hz (16 spc)
Range	0 - 220 VDC
Pulse Type	0->1->0, 1->0->1, KYZ
Functionality	Triggers based on events / Energy pulse counting
Isolation Connector	125V
RELAY OUTPUT	
Power Over Ethernet (PoE- Out)	1 (Available as Output - 48V / 13 Watt)

See also:

- [System Overview](#)
- [Warranty](#)
- [Acronyms](#)



WARNINGS

REVIEW THE ENTIRE MANUAL BEFORE USING THE INSTRUMENT AND ITS ACCESSORIES

OBSERVE ALL WARNINGS AND CAUTIONS

DO NOT OPERATE THE INSTRUMENT AROUND EXPLOSIVE GAS OR VAPOR

AVOID WORKING ALONE

BEFORE USE, INSPECT THE INSTRUMENT, LEADS AND ACCESSORIES FOR MECHANICAL DAMAGE, AND REPLACE WHEN DAMAGED

PAY SPECIAL ATTENTION TO THE INSULATION SURROUNDING THE CONNECTORS AND PLUGS

REMOVE ALL ACCESSORIES THAT ARE NOT IN USE

MAKE SURE THE INSTRUMENT IS PROPERLY GROUNDED TO A PROTECTIVE EARTH GROUND

DO NOT APPLY INPUT VOLTAGES ABOVE THE RATING OF THE INSTRUMENT AS SHOWN ON THE NAME PLATE

DO NOT INSERT METAL OBJECTS INTO CONNECTORS AND OPENINGS

NEVER OPEN THE INSTRUMENT'S ENCLOSURE DURING OPERATION; DANGEROUS VOLTAGES ARE PRESENT

USE THE INSTRUMENT ONLY AS SPECIFIED IN THIS MANUAL, OR THE PROTECTION PROVIDED BY THE INSTRUMENT MAY BE IMPAIRED

DO NOT EXPOSE THE INSTRUMENT TO EXTREME MOISTURE AND OR RAIN

TO AVOID SHOCK OR FIRE

VERIFY THAT THE UNIT IS DISCONNECTED FROM THE MAIN POWER SUPPLY

INSPECT ALL ELECTRICAL AND MECHANICAL CONNECTIONS VISUALLY FOR MECHANICAL DAMAGE AND INTEGRITY OF COMPONENTS AND ACCESSORIES

INSPECT CURRENT TRANSFORMER WIRING FOR PROPER DIRECTION THROUGH THE CYLINDRICAL APERTURE OF THE CURRENT SAMPLING MODULE

TEST ALL CONTROL WIRING TO ENSURE SECURE SEATING IN TERMINALS

BEFORE USE, INSPECT THE INSTRUMENT, LEADS AND ACCESSORIES FOR MECHANICAL DAMAGE, AND REPLACE WHEN DAMAGED

DO NOT OPERATE THE INSTRUMENT OR ITS ACCESSORIES IF IT BECAME WET FOR ANY REASON

See also:

- [What You'll Need](#)
- [Unpacking Components & Accessories](#)
- [G4500 BLACKBOX Unit](#)
- [G3500 BLACKBOX Unit](#)



What You'll Need

Familiarize yourself with the [G4500](#) & [G3500](#) BLACKBOX Unit, [Components & Accessories](#). In addition, ensure that you follow the outlined [Safety Precautions](#). You will need the following tools & additional items for the initial installation:

- Wire Strippers
- Phillips Screwdriver
- Flat Head Screwdriver
- Portable BLACKBOX Unit, Components & Accessories
- This User Guide

See also:

- [Safety Precautions](#)
- [Unpacking Components & Accessories](#)
- [G4500 BLACKBOX Unit](#)
- [G3500 BLACKBOX Unit](#)







QUANTITY	ILLUSTRATION	DESCRIPTION & PART NUMBER
DEVICE, COMPONENTS & ACCESSORIES		
1		<p>Portable BLACKBOX Device</p> <ul style="list-style-type: none"> ▪ G4500 BLACKBOX: SPG-4500-0090 ▪ G3500 BLACKBOX: SPG-3500-0090 <p>SEE ALSO</p> <ul style="list-style-type: none"> ▪ Product Selection Guide
1		<p>G4150 Mobile Analysis Lab</p> <ul style="list-style-type: none"> ▪ SNT-4420-0000¹
1		<p>Elspec BLACKBOX Installation & Demonstration Disc [SMX-0408-0103] Containing:</p> <ul style="list-style-type: none"> ▪ INVESTIGATOR Software V4 SOF-4001-0000 ▪ PQSCADA Software V4 SOF-4000-0000 ▪ Generic Configuration Utility V1 SOF-4003-0000 ▪ Elspec Search Utility V1 SOF-4004-0000 ▪ Software Support Utilities ▪ G4500/G3500 Quick Reference Guide V1 SMR-3011-0110 ▪ G4500 User Guide V1 SMX-0603-0100 ▪ PQSCADA User Manual V4 SMX-0619-0100 ▪ INVESTIGATOR User Manual SMM-5011-0809 ▪ G4500/G3500 Brochure V1 SMX-0218-0100 ▪ Tutorials V3 SMX-1608-0100

Unpacking Components & Accessories

The Portable BLACKBOX is shipped from Elspec's factory in a sealed case to protect it from damage during transportation. The small parts are shipped in a sealed bag with the unit.

TO UNPACK THE UNIT & ITS ACCESSORIES

Remove the unit & all of the following components from the casing:



QUANTITY	ILLUSTRATION	DESCRIPTION & PART NUMBER
1		Carrying Trolley Case (For Mobility) <ul style="list-style-type: none"> MEB-2999-0000
1		5 AC VOLTAGE TEST LEADS & CLIPS: <ul style="list-style-type: none"> Black Voltage Cord with Crocodile Clip + Fuse (3M) EAH-4303-5100 Red Voltage Cord with Crocodile Clip + Fuse (3M) EAH-4303-5200 Blue Voltage Cord with Crocodile Clip + Fuse(3M) EAH-4303-5300 Yellow Voltage Cord with Crocodile Clip + Fuse(3M) EAH-4303-5400 Green Voltage Cord with Crocodile Clip(3M) EAH-4303-9500
1		2 DC VOLTAGE TEST LEADS & CLIPS²: <ul style="list-style-type: none"> Black Voltage Cord with Crocodile Clip + Fuse (3M) EAH-4303-5100 Red Voltage Cord with Crocodile Clip + Fuse (3M) EAH-4303-5200
1		<u>Custom Clamp 3-Flexible Current Probes (Adjustable 30/300/3000A)</u> <ul style="list-style-type: none"> SOA-3003-0270
1		<u>Custom Clamp 1-Flexible Current Probe (Adjustable 30/300/3000A)</u> <ul style="list-style-type: none"> SOA-3000-0270
1		Power Cable for Cont. 10A/125V, Straight, 1.8M, Black: <ul style="list-style-type: none"> Europe: EPC-2012-2190 North America: EPC-7012-2190





QUANTITY	ILLUSTRATION	DESCRIPTION & PART NUMBER
1		48VDC Terminal Block Connector (RoHS Compliant): <ul style="list-style-type: none"> ENT-1002-0190
1		Temperature Sensor Terminal Block Connector PT100 Type (RoHS Compliant) <ul style="list-style-type: none"> ENT-1002-0191
1		RS485/422 Communication Terminal Block Connector (RoHS Compliant) <ul style="list-style-type: none"> ENT-1004-0190
1		Multi IO Terminal Block Connector (RoHS Compliant) <ul style="list-style-type: none"> ENT-2008-0190
1		Relay Terminal Block Connector (RoHS Compliant) <ul style="list-style-type: none"> ENT-1003-0190
1		LAN Communication Cord Length: 2M <ul style="list-style-type: none"> TOE-0010-0013
1		Relay Terminal Block Connector (RoHS Compliant) <ul style="list-style-type: none"> ENT-1002-0190







¹ The mobile analysis lab may be excluded from your Order, if so preferred. The default keyboard for the lab is English. Please ensure that your order has indicated your choice of preference

² G4500 unit only

Orders for optional accessories will be delivered as well in a sealed casing. Unpack these parts from their sealed bags:

OPTIONAL ACCESSORIES		
QUANTITY	ILLUSTRATION	DESCRIPTION & PART NUMBER
As Ordered		GPS (Global Position System) (For Mobile Time Synchronization) <ul style="list-style-type: none"> SOA-0232-0400
As Ordered		Multi-Frequency 3.5G Wireless Modem (For Fast Mobile Communication Access) <ul style="list-style-type: none"> SCM-0001-0000
As Ordered		Protective Weatherproof Pelican Case (IP64) <ul style="list-style-type: none"> SPG-4501-0090
As Ordered		DWL-P50 Standard POE to Remote Devices (8 - 12 Volts Adapter) <ul style="list-style-type: none"> EBO-5050-0000
As Ordered		<u>Custom Clamp 3-Flexible Current Probes</u> <ul style="list-style-type: none"> SOA-3003-0270
Current Range 30A / 300A / 3000A AC RMS		
Operating Temperature -20°C to + 65°C		
Probe Cable Length 610mm (24")		
		Probe Cable Diameter 194mm (7.5")

QUANTITY	ILLUSTRATION	DESCRIPTION & PART NUMBER
As Ordered		<p><u>Custom Clamp 3-Flexible Current Probes</u></p> <ul style="list-style-type: none"> SOA-3000-0270 <p>Current Range 30A / 300A / 3000A AC RMS</p> <p>Operating Temperature -20°C to + 65°C</p> <p>Probe Cable Length 610mm (24")</p> <p>Probe Cable Diameter 194mm (7.5")</p>
As Ordered		<p><u>DC Current Custom Clamp</u></p> <ul style="list-style-type: none"> SOA-0270-1400 <p>Current Measurement 1,500A DC / 1,000A AC</p> <p>Output Signal 1m V/A, 10m V/A</p> <p>Operating Temperature - 20 °C to + 60 °C</p> <p>Cable Length 1.4M</p>
As Ordered		<p><u>1-6 A Mini Clamp</u></p> <ul style="list-style-type: none"> SOA-0010-0500 <p>Measurement Range Up to 6A AC (1A Nominal)</p> <p>Output Signal 100 mV/A</p> <p>Operating Temperature - 20 °C to + 60 °C</p> <p>Cable Length 1.2M</p>
As Ordered		<p><u>100 A Mini Clamp</u></p> <ul style="list-style-type: none"> SOA-0180-5000 <p>Measurement Range Up to 100A_{PK} AC</p> <p>“Hole” Dimensions 10mm Max</p> <p>Operating Temperature - 20 °C to + 60 °C</p> <p>Cable Length 1.2M</p>

QUANTITY	ILLUSTRATION	DESCRIPTION & PART NUMBER
As Ordered		<u>300 A Flexible Current Clamp</u> <ul style="list-style-type: none"> SOA-9091-3000
		Measurement Range 9A ÷ 1050A
		Output Signal AC: 46mV/1KA
		Operating Temperature -20°C to + 60°C
		Cable Length 2m
As Ordered		<u>3000 A Flexible Current Clamp</u> <ul style="list-style-type: none"> SOA-9045-3001
		Measurement Range 10Hz ÷ 20kHz
		Output Signal AC: 46mV/1KA
		Operating Temperature -20°C to + 60°C
		Cable Length 2m
As Ordered		Adaptor - Elspec Clamps to BNC (160cm) <ul style="list-style-type: none"> SOA-0270-0000
As Ordered		Adaptor - Elspec Clamps to Fixed Banana (60cm) <ul style="list-style-type: none"> SOA-0270-0001
As Ordered		Adaptor - Elspec Clamps to Separated Banana (160cm) <ul style="list-style-type: none"> SOA-0270-0002
As Ordered		Extension Cable for Elspec Clamps (600cm) <ul style="list-style-type: none"> SOA-4500-0000

See also:

- [Safety Precautions](#)
- [What You'll Need](#)
- [G4500 BLACKBOX Unit](#)
- [G3500 BLACKBOX Unit](#)

The G4500 BLACKBOX Portable PQ Analyzer

The innovative design of the G4500 BLACKBOX has been uniquely adapted for PQ Analysis at any location. It continuously records all waveform data at a sampling rate for Voltage 1,024 samples per cycle & Current 256 samples per cycle. With an onboard memory of 32GB you can capture everything for more than a year depending on the selected resolution & the individual network condition. It is important to remember that with the built-in PQZIP compression this onboard memory is equivalent to 32TB, enabling you to get to the root cause of all your PQ Anomalies. It features an ultra capacitors' ride-through for up to 25 seconds, an AC/DC power supply, DC/DC converter, can be powered by Power of the Ethernet (PoE In) or by an onboard battery for up to 2 Hours.

The front panel of the unit mainly facilitates the communication interfaces, the auxiliary power supply & I/O module. It also facilitates one of the important features of the device, namely the remote Wifi antenna & activity indicator.

The rear panel houses another important feature of the G4500, namely the sensor sockets for all the probes. You may use any custom / Elspec probes supplied with the device. Simply plug it in & all the probes will be automatically recognized. The rear panel also houses the On/Off Switch of the Main Power & Inlet Socket.

The illustrations & tables below will serve as a navigational map of all the unit's controls & indicators.

Physical layout of the controls & indicators of the G4500's Front Panel:

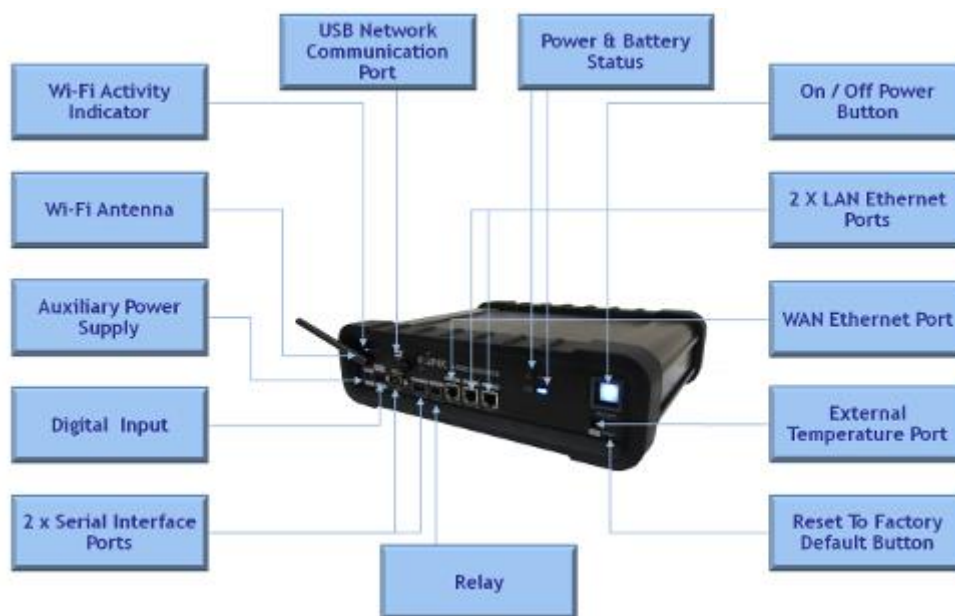

Physical layout of the controls & indicators of the G4500's Rear Panel:



INDICATOR / CONTROL	DETAILED USAGE REFERENCE
FRONT PANEL	
Wi-Fi Activity & Antenna	Wireless Single PC Connection
Auxiliary Power Supply	Unit Powering
Digital Inputs	IO Ports
Serial Ports	Establish 1ST Time Connection
USB Network Communication Port	Establish 1ST Time Connection
Battery Indicator	Battery Replacements
Power Indicator	Unit Powering
Main Power Supply On/Off Switch	Unit Powering
LAN Ports	Establish 1ST Time Connection
WAN Port	Establish 1ST Time Connection
External Temperature Port	IO Ports
Reset Button	Instrument Settings
Relay Port	IO Ports

REAR PANEL	
Voltage Clamp Inputs	Connect Voltage Probes
Current Clamp Inputs	Connect Current Clamps
DC Current Input	Connect Current Clamp
DC Voltage Inputs	Connect Voltage Probes
Main Power On/Off Switch	Unit Powering
Main Power Inlet Socket	Unit Powering

See also:

- [Safety Precautions](#)
- [What You'll Need](#)
- [Unpacking Components & Accessories](#)
- [G3500 BLACKBOX Unit](#)

The G3500 BLACKBOX Portable PQ Analyzer

The innovative design of the G3500 BLACKBOX has been uniquely adapted for PQ Analysis at any location. It continuously records all waveform data at a sampling rate for Voltage 512 samples per cycle & Current 512 samples per cycle. With an onboard memory of 256MB you can capture everything for more than a year depending on the selected resolution & the individual network condition. It is important to remember that with the built-in PQZIP compression this onboard memory is equivalent to 256GBG, enabling you to get to the root cause of all your PQ Anomalies. It features an ultra capacitors' ride-through for up to 25 seconds, an AC/DC power supply, DC/DC converter, can be powered by Power of the Ethernet (PoE In) or by an onboard battery for up to 2 Hours.

The front panel of the unit mainly facilitates the communication interfaces, the auxiliary power supply & I/O module.

The rear panel houses another important feature of the G3500, namely the sensor sockets for all the probes. You may use any custom / Elspec probes supplied with the device. Simply plug it in & all the probes will be automatically recognized. The rear panel also houses the On/Off Switch of the Main Power & Inlet Socket.

The illustrations & tables below will serve as a navigational map of all the unit's controls & indicators.

Physical layout of the controls & indicators of the G3500's Front Panel:



Physical layout of the controls & indicators of the G3500's Rear Panel:



INDICATOR / CONTROL	DETAILED USAGE REFERENCE
FRONT PANEL	
Auxiliary Power Supply	Unit Powering
Digital Input	IO Ports
Serial Ports	Establish 1ST Time Connection
Battery Supply	Battery Replacements
Power Indicator	Unit Powering
LAN Ethernet Port	Establish 1ST Time Connection
Reset Button	Instrument Settings
Relay Port	IO Ports
REAR PANEL	
Voltage Clamp Inputs	Connect Voltage Probes
Current Clamp Inputs	Connect Current Clamps
Main Power On/Off Switch	Unit Powering
Main Power Inlet Socket	Unit Powering

See also:

- [Safety Precautions](#)
- [What You'll Need](#)
- [Unpacking Components & Accessories](#)
- [G4500 BLACKBOX Unit](#)

Installation

This section contains the installation & setup procedure for the Portable BLACKBOX that is quick & simple to follow. After you have installed your BLACKBOX device, you can:

- Monitor the Quality of your Electrical Power,
- Monitor PQ Parameters according to EN50160, IEC61000-4-30 & Customized Standards
- Store a 1000 Times More than other typical file formats with PQZIP

QUICK & SIMPLE INSTALLATION

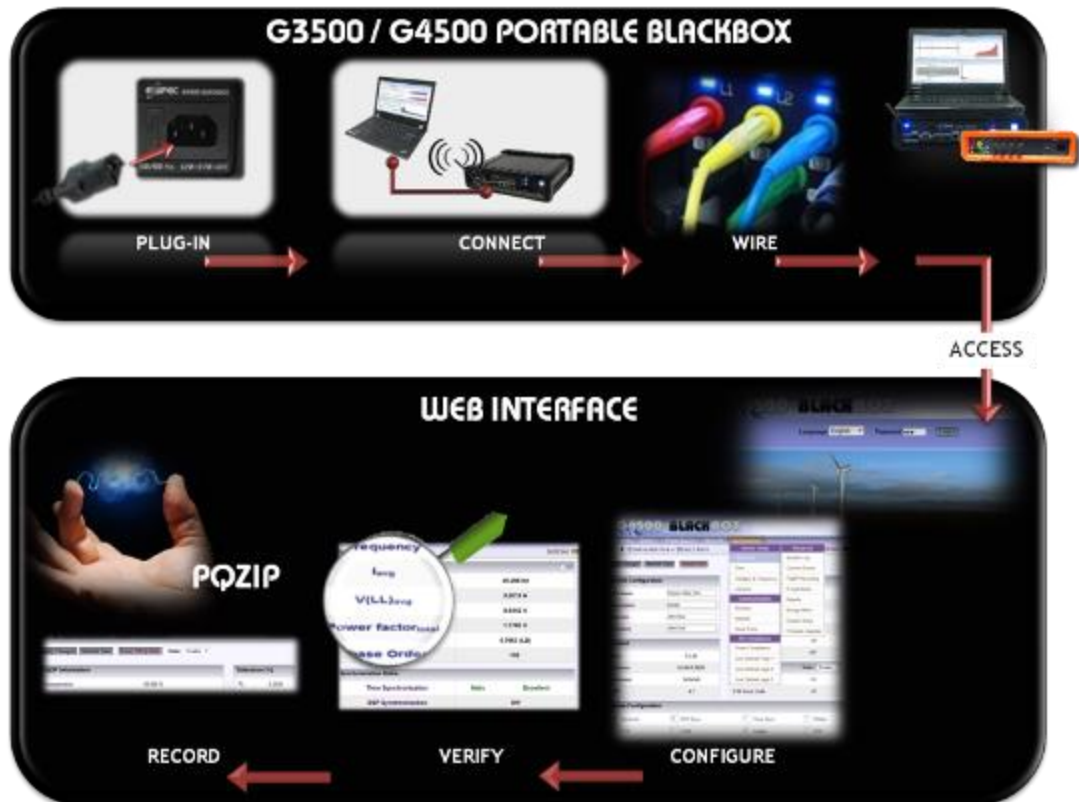

The simple Step-x-Step procedure includes:

- [Unit Powering](#)
- [Establish 1st Time Connection](#)
- [Plug in & Play the Voltage & Current Probes](#)
- [Unit Access](#)
- [Quick Unit Configuration](#)
- [Verify Measurement Readings](#)
- [Enable PQZIP Recording](#)

! WARNING

Before you start ensure that the panel is de-energized & that you take the necessary Safety Precautions!

Unit Powering

You may either power up either G4500 / G3500 Portable BLACKBOX by using the main AC Power Supply / the Auxiliary Power Supply / Battery Power Supply:

connect by using the AC POWER SUPPLY:

! WARNING

85-260V AC \pm 10%, 50/60Hz

OR

120-370V DC

35-55V DC Watt Maximum

- 2A/250V Fuse Holder
- Use only suitable fuse replacement!
- Make sure the Instrument is properly grounded through the power cord to protective earth ground

- On the Rear Panel connect the female end of the [Power Cable](#) to the [Main Power Supply](#) inlet socket of the unit:



- Connect the male plug end of the Power Cable to the electrical supply outlet

- [On the Front Panel turn on the Main Power Supply](#) Switch to the ON position:



- [On the Rear Panel turn on the Main Power Switch](#) to the ON position:



- [Verify that the unit is running on AC Power](#) by using the status indicator lights:

Flashing Blue Main Power Applied, Battery Charging

Solid Blue Main Power Applied, Battery Fully Charged



connect by using the Auxiliary Power Supply:

WARNING

48V DC
(35- 55V)

35 Watt Maximum

- No replaceable fuse protection!
- Do not allow significant overvoltage!
- The 48VDC power supply should be isolated from the mains by double or reinforced insulation

- [On the Front Panel](#) connect the female end of the [Auxiliary Cable](#) to the [Auxiliary Port](#) of the unit to the corresponding +/- connection:



- [On the Front Panel](#) turn on the [Main Power Supply](#) Switch to the **ON** position:



- [Verify that the unit is running on Auxiliary Power](#) by using the status indicator lights:

Flashing Blue

Main Auxiliary Power Applied,
Battery Charging

Solid Blue

Main Auxiliary Power Applied,
Battery Fully Charged



Power the unit by using the Battery Supply:

The BLACKBOX Portable contains an internal, uninterrupted power supply module providing a short period of self-powered measurements sessions &/or power supply interruptions ride-through. The Internal UPS system contains a lithium battery for a up to 2 hours of fully- functioning operation & a super capacitors module allowing an additional 25 seconds of short interruptions ride-through even in the case of the main battery being fully discharged. The battery & super capacitors modules require no maintenance and are designed for a long service life. However, if the battery shows a significant decrease in performance, it should be replaced with a factory original. Consult with your local Elspec agency for replacement battery ordering information & see Battery Replacement, in order to change your Battery.

Procedure for using the Battery Supply:

- [On the Front Panel turn on the Main Power Supply Switch to the ON position:](#)



- [Verify that the unit is running on Battery Power](#) by using the status indicator lights:

Red **Powered by the Internal Battery**

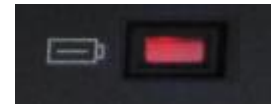

- Go to the next step - [Unit Wiring](#)

see also:

- [About Quick Installation](#)
- [About Portable Wiring](#)
- [Plug and Play Voltage & Current Probes](#)
- [Grounding](#)
- [Establish 1st Time Connection](#)
- [Unit Access](#)
- [About Quick Configuration](#)
- [Verify Measurement Readings](#)
- [Enable PQZIP Recording](#)

G4500 & G3500 Unit Wiring

An essential part of the Wiring Procedure is the Power Configuration, which is configured in the Web Interface. Prior to proceeding with [Plugging in & Playing your Voltage & Current Probes](#), familiarize yourself with the types of Power Topology the BLACKBOX Portable supports & [Grounding](#) of the unit.

BLACKBOX PORTABLE POWER TOPOLOGY SUPPORTS

The BLACKBOX is designed to serve in virtually any power topology configuration. The diagrams below outline the types of topologies with their applicable Configuration in Elspec's Web Interface. It includes the Portable BLACKBOX configurations followed by the actual power configuration in brackets:

Single LN [SINGLE PHASE WITH NEUTRAL]:

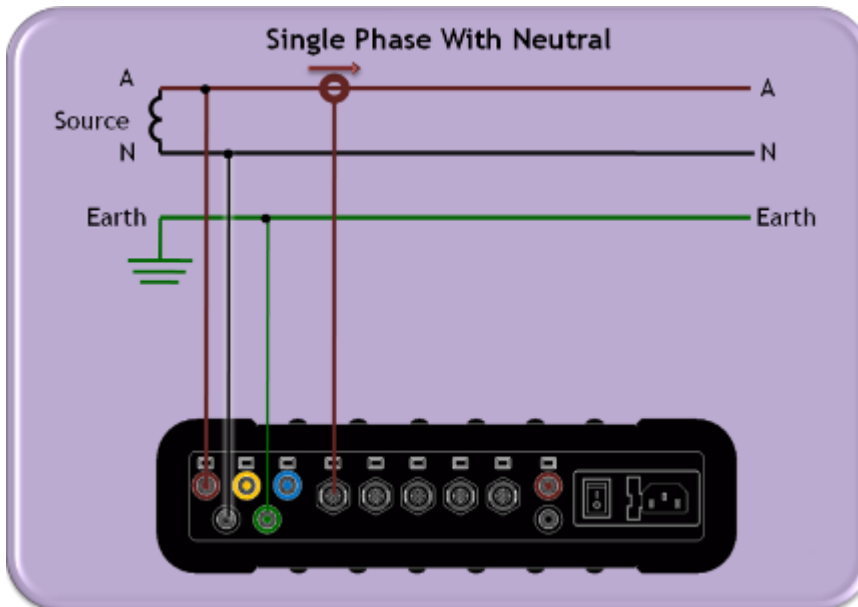

Single LL [SINGLE PHASE WITHOUT NEUTRAL]:

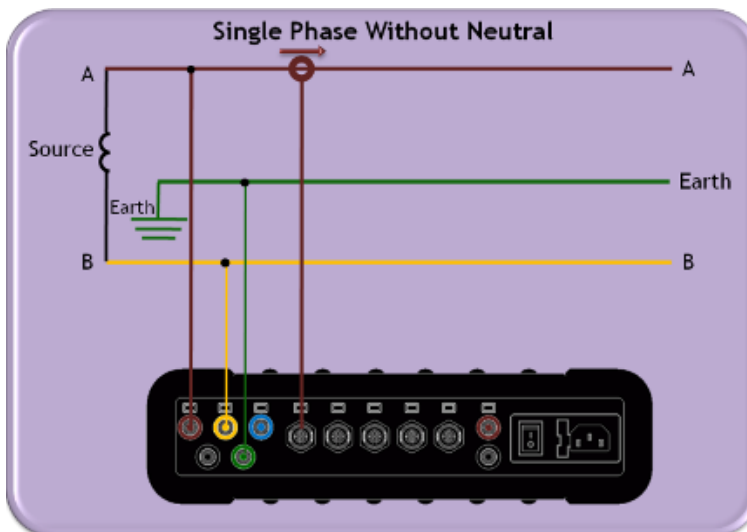

2Phase TR [SINGLE SPLIT PHASE]:

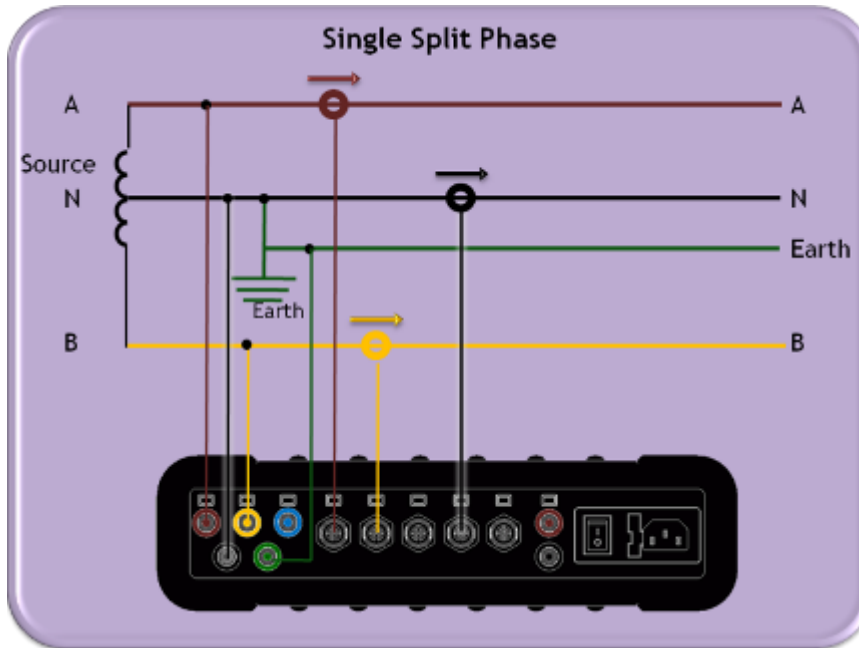

delta 3 wires [THREE WIRE DELTA]:

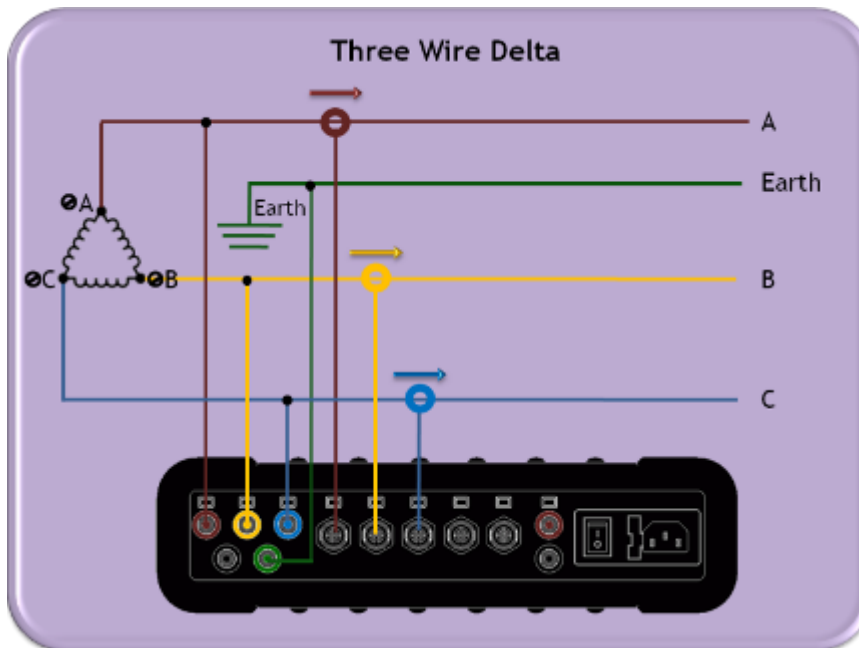

delta 3 wires [Grounded Delta]:

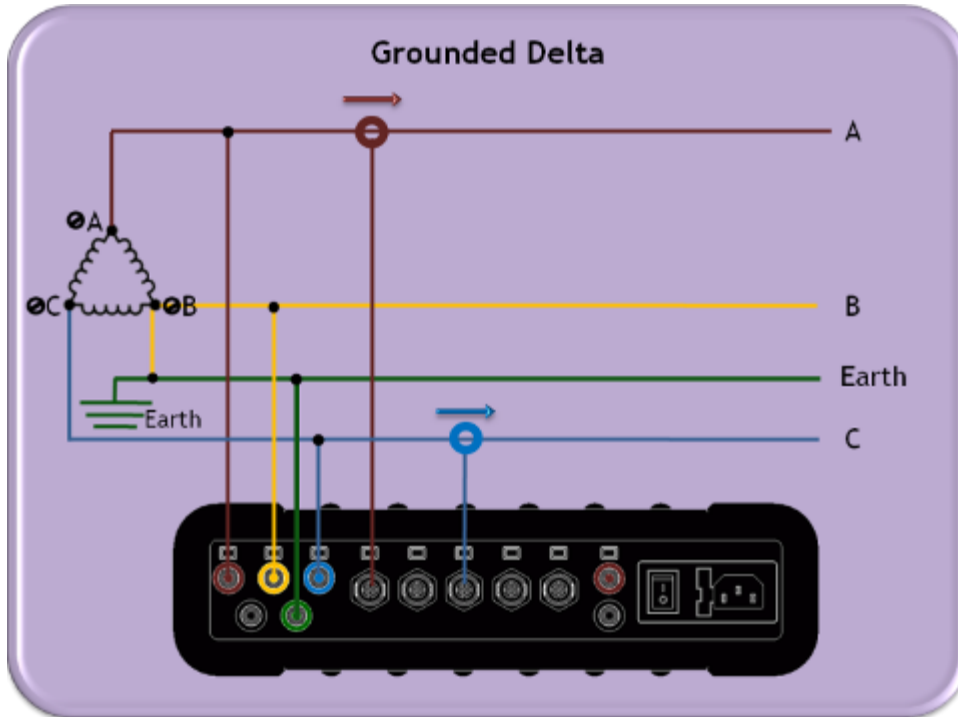

wye 4 wires [four wire wye]:

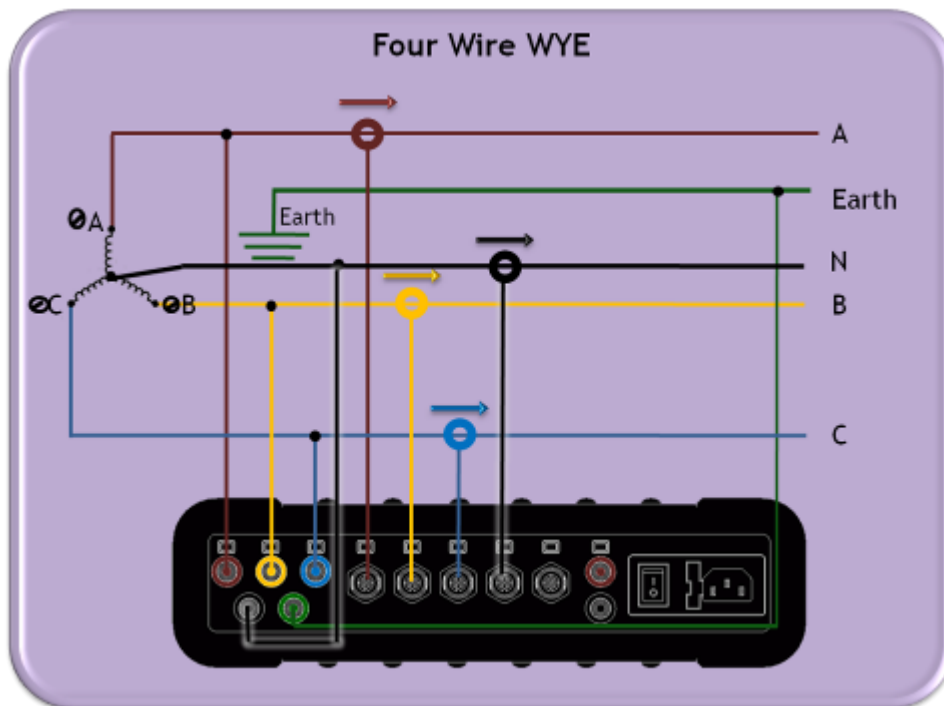

wye 4 wires [three wire wye]:

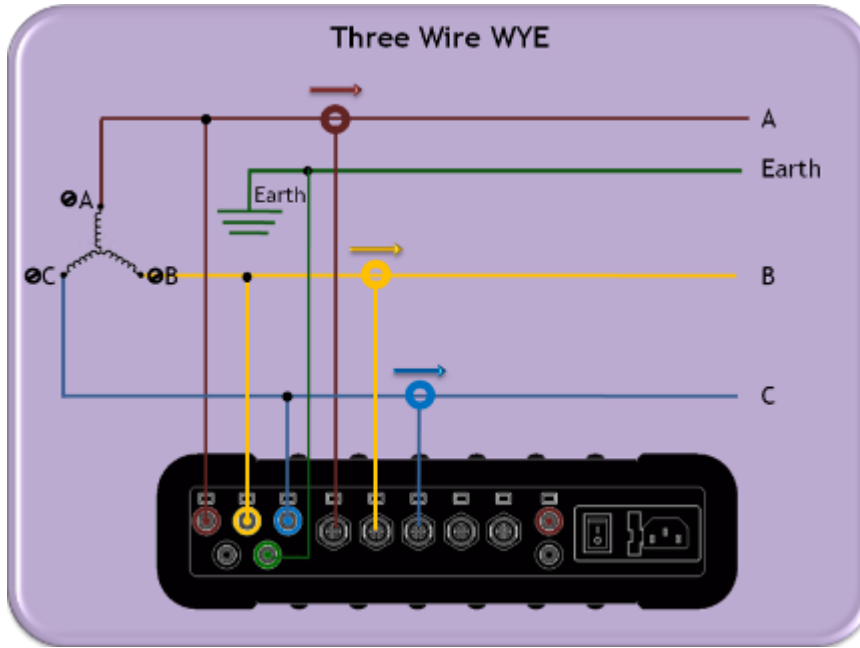

Delta 3 wires [delta high leg]:

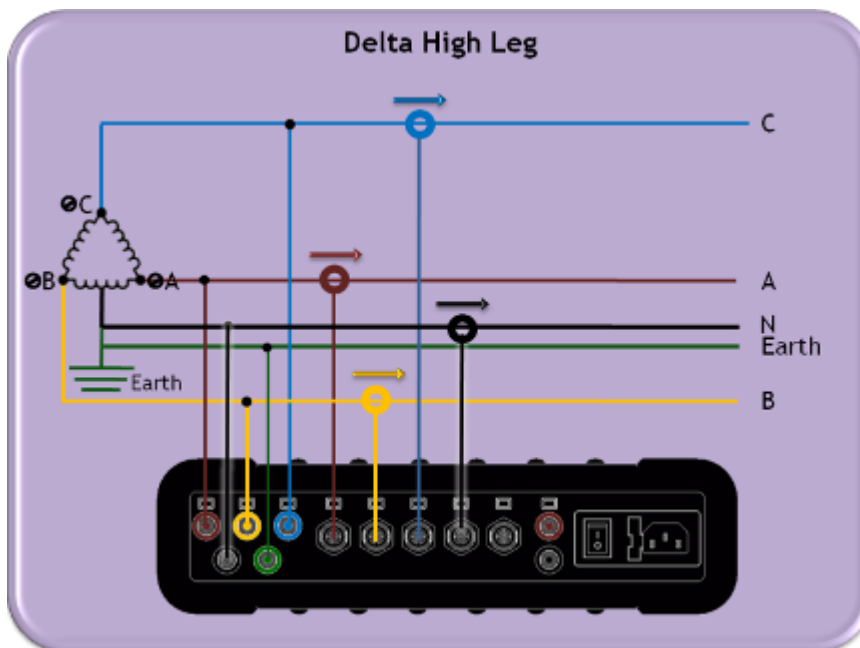

Delta 3 wires [delta Open Leg]:

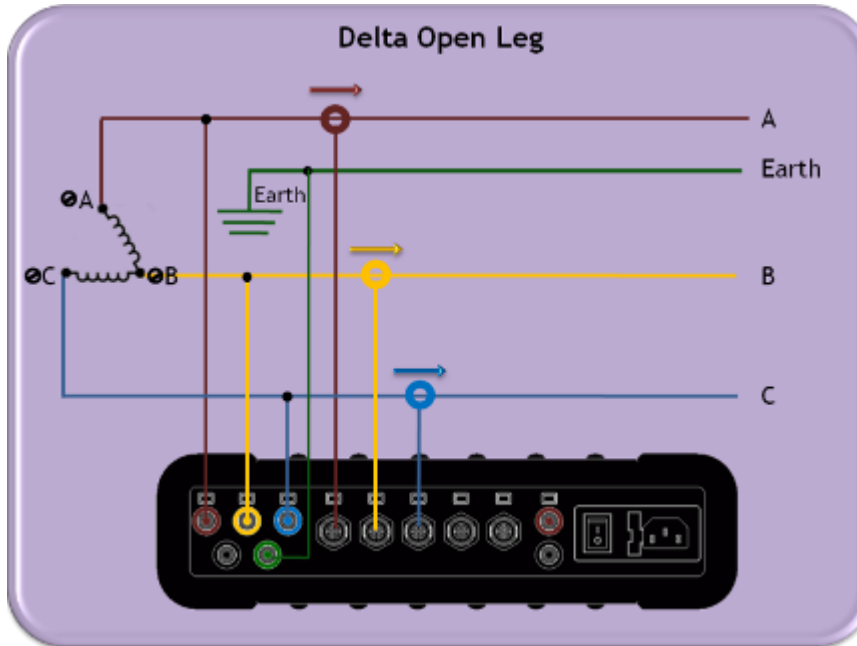

see also:

- [About Quick Installation](#)
- [Unit Powering](#)
- [Plug and Play Voltage & Current Probes](#)
- [Grounding](#)
- [Establish 1st Time Connection](#)
- [Unit Access](#)
- [About Quick Configuration](#)
- [Verify Measurement Readings](#)
- [Enable PQZIP Recording](#)

Grounding

The Portable BLACKBOX contains two independent ground systems, one for measurements & one for safety. Internally the ground systems are isolated in order to avoid ground loops. Externally they may be safely connected to the same or different ground systems.

- **Point 1 - Measurement Ground:** The reference point for measured electrical system,
- **Point 2 - Safety Ground:** The reference for the line cord ground. Enclosure for connectors related metal parts:

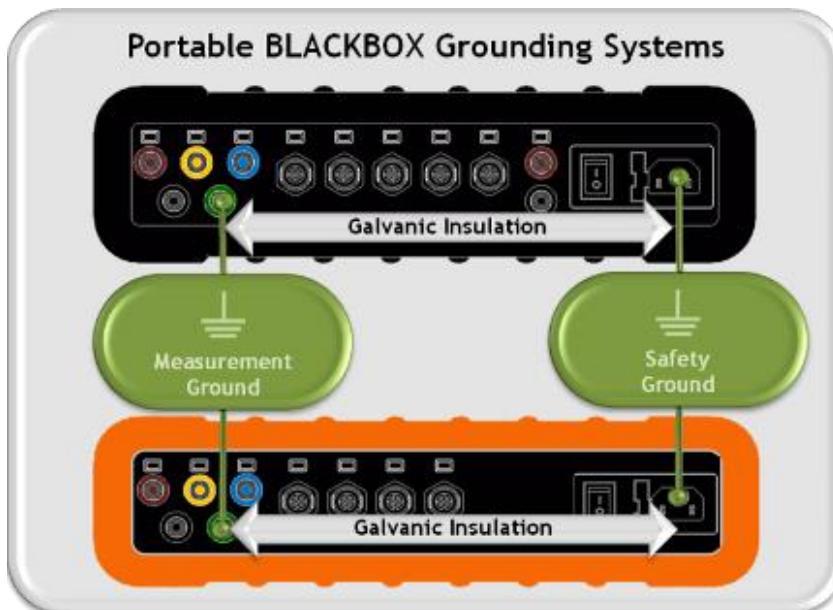

NOTE NOTE NOTE

- Maximum permitted voltage between Measurement & Safety Grounds is 2kV DC or 1.5kV AC.
- The Ground input is the reference for all channels therefore it is essential to connect it properly.

- Proceed to the next step - [Plug and Play Voltage & Current Probes](#)

see also:

- [About Quick Installation](#)
- [Unit Powering](#)
- [About Portable Wiring](#)
- [Plug and Play Voltage & Current Probes](#)
- [Establish 1st Time Connection](#)
- [Unit Access](#)
- [About Quick Configuration](#)
- [Verify Measurement Readings](#)
- [Enable PQZIP Recording](#)

Plug & Play - Voltage & Current Probes

The Portable BLACKBOX houses [5 x AC Voltage](#), [4 x AC Current](#) & [1 x AC/DC Current](#) Sockets. In addition the G4500 houses [2 x VDC Sockets](#). It is a simple matter of plugging in the Voltage & Current Probes into the device & it will be automatically recognized.

The BLACKBOX is designed to serve in virtually any power topology configuration, see Circuit Topologies in order to interface your device with your circuit topology.

NOTE NOTE NOTE

- **Current Clamps:** The Portable BLACKBOX is certified to measure currents only when using Certified 61010-2-032 Third Edition Current Clamps.
- **Voltage Clamps:** The Portable BLACKBOX is certified to measure voltage only when using Certified to 61010-031 Third Edition Voltage Clamps.

plug in the ac voltage probes:

- Plug in the [Voltage Probes](#) into the applicable sockets located on the [Rear Panel](#). Plug the phase & ground cables in as:
 - L1 to L1 (Red to Red)
 - L2 to L2 (Yellow to Yellow)
 - L3 to L3 (Blue to Blue)
 - Ground to Ground (Green to Green)
 - Earth to Earth (Black to Black)



- Attached [Crocodile Ends of the Probes](#) to the Measured Power Source:



- The LED light will illuminate confirming a solid connection & the Voltage Levels are above 10% of the nominal value:



SPECIFICATION	G4500	G3500
Maximum Voltage Input	1KV	1KV
Nominal Voltage Range	110 to 690V	110 to 690V
Maximum Peak Measurement Voltage	8KV	8KV
Input Impedance	3MΩ	3MΩ
Bandwidth	25kHz	12.5kHz
Nominal Frequency	42.5Hz to 69Hz	42.5Hz to 69Hz

plug in the current probes:

You may use any clamp (either Elspec / Custom clamps). The clamps convert current to low voltage.

- Plug in the [Current Probes](#) into the applicable sockets located on the [Rear Panel](#) (Pay attention to the phase connections, as the channels are calibrated according to the clamps - I1 for I1; I2 for I2; I3 for I3; I4 for I4 & IDC for the DC Clamp):



- Connect the measurement end to the measured power source:



- The LED light will illuminate confirming a solid connection:



SPECIFICATION	G4500	G3500
Number of Inputs	4 (3 Phases & Neutral) + DC/Ground	4 (3 Phases & Neutral)
Maximum Peak Measurement	I1 to I4: 10 V _{pk} I5: 3 V _{pk} From Clamp	I1 to I4: 10 V _{pk} From Clamp
Type	Clamp On Current Transformer With mV Output	Clamp On Current Transformer With mV Output
Range	I1 to I4: 0 to 10 V _{pk} I5: 0 to 3 V _{pk} From Clamp	I1 to I4: 0 to 10 V _{pk} From Clamp
Burden	0.05VA (Typical) @ 5 IRMS	0.05VA (Typical) @ 5 IRMS
Bandwidth	25kHz (Typical) @ 5 IRMS	12.5kHz

plug in the G4500'S VDC probes:

The G4500 facilitates Auxiliary DC(+) & DC(-) voltage & current inputs & provides an independent input to the main AC/DC channel DC voltage readings. The measurement range ranges from -1000VDC to +1000VDC at a rate of once every second. This is mainly suitable for a voltage converter DC link side reading while the main voltage channels are on the grid side.

- Plug in the [DC Probes](#) into the applicable sockets located on the [Rear Panel](#) - Red(+) & Black(-):



- Connect the measurement end to the measured power source
- No configuration is necessary for the automatically recognized DC V/I Probes, you may however choose to **Enable / Disable** the recording at your own choosing. See [Capture DC](#).

SPECIFICATION	
Maximum Voltage Input	1KV
Galvanic Insulation from Main AC / DC Channels	3KV
Recording Resolution	200 μ s

- Go to the next step - [Establishing a 1st Time Connection](#)

see also:

- [About Quick Installation](#)
- [Unit Powering](#)
- [About Portable Wiring](#)
- [Grounding](#)
- [Establish 1st Time Connection](#)
- [Unit Access](#)
- [About Quick Configuration](#)
- [Verify Measurement Readings](#)
- [Enable PQZIP Recording](#)

Establish 1st Time Connection

A quick & simple connection can be established to your Network or G4150 or your local PC by using the Portable BLACKBOX's fast Ethernet ports (10/100 MB) / Wireless Link.

G4500 Portable BLACKBOX:

- **Wi-Fi:** Convenient Wireless Connection
- **WAN:** Broadband router (ADSL/ Cable / Cellular) for Internet accessibility - [See Communication](#)
- **LAN1:** G4150/ DHCP/ PC / Laptop Connection - [See Communication](#)
- **LAN2/LCD:** Direct connection to LAN Network of Computers - [See Communication](#)
- **Serial Interface Ports:** [See Communication](#)

G3500 Portable BLACKBOX:

- **LAN/LCD:** Main connection port (G4150/ DHCP / PC/ Laptop/ LAN Network of Computers)
- **Serial Interface Ports:** [See Communication](#)

G4500 WI-FI CONNECTION

Equipped with a built-in IEEE 802.11 g/b router configured as an industry standard access point, the G4500 provides convenient & instant connectivity to your G4150, including to a PC/Laptop that is Wi-Fi enabled.

- [After you have switched on](#) your G4500 Portable PQ Analyzer, search for the device by its unique [S/N](#):

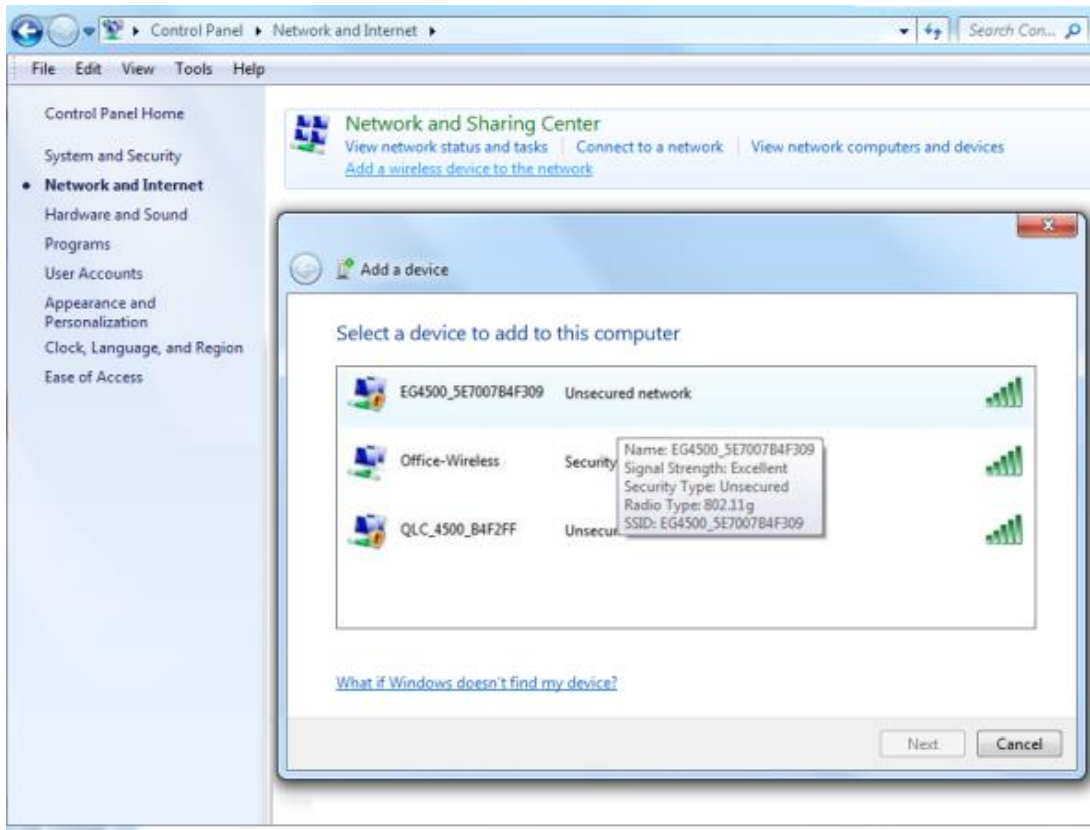

- The S/N is located on the G4500's name plate:



- The Wi-Fi Activity Indicator will confirm connection (Flashing / Solid Blue):



G3500 LAN/LCD CONNECTION

- [After you have switched on](#) your G3500 Portable PQ Analyzer, connect the [LAN Communication Cord](#) to the port marked LAN/LCD on the units' [Front Panel](#):



- The green link-LED of the LAN1 connector begins to flash as Windows begins communicating with the unit
- Wait for about 2 minutes as the Windows operating system reverts to the default "No Server" IP configuration
- When this is completed, the "Local Area Connection Status" icon in the "Quick Start" tray will change to "Limited or no connectivity":

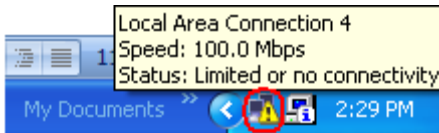

see also:

- [About Quick Installation](#)
- [Unit Powering](#)
- [About Portable Wiring](#)
- [Grounding](#)
- [Plug and Play Voltage & Current Probes](#)
- [Unit Access](#)
- [About Quick Configuration](#)
- [Verify Measurement Readings](#)
- [Enable PQZIP Recording](#)

G4500 / G3500 Unit Access

Once you have [Connected the Device for the 1st Time](#), you may access your Portable BLACKBOX Unit by simply clicking the WEB Hyperlink button in your Elspec's Search Utility. Alternatively you can simply access the device directly via the Internet Explorer by inserting the Device's IP address directly (address is also indicated in Elspec's Search Utility).

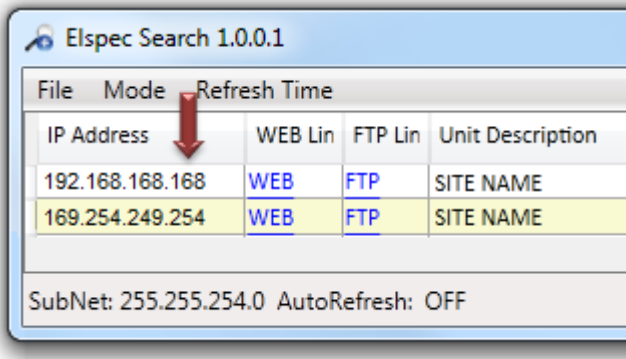

Access Elspec's search utility:

- After you have Copied the Utility on your Desktop, access it by clicking on the Elspec's Search Icon:

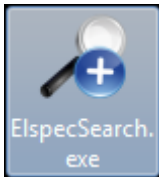

- Initially, the program may trigger a verification warning similar to the one below. You may proceed by clicking Run:

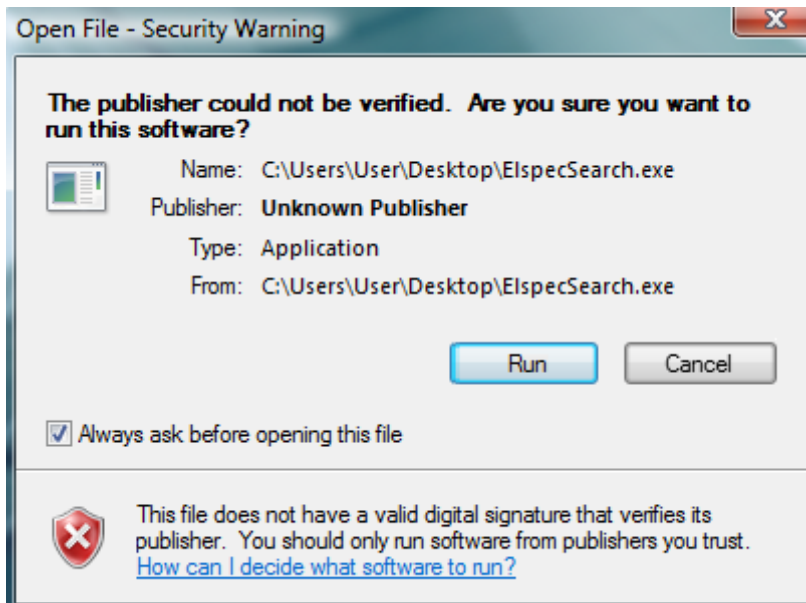

- A scan procedure is initiated; the Elspec Search utility appears as a grid displaying all BLACKBOX devices found on the intranet network:

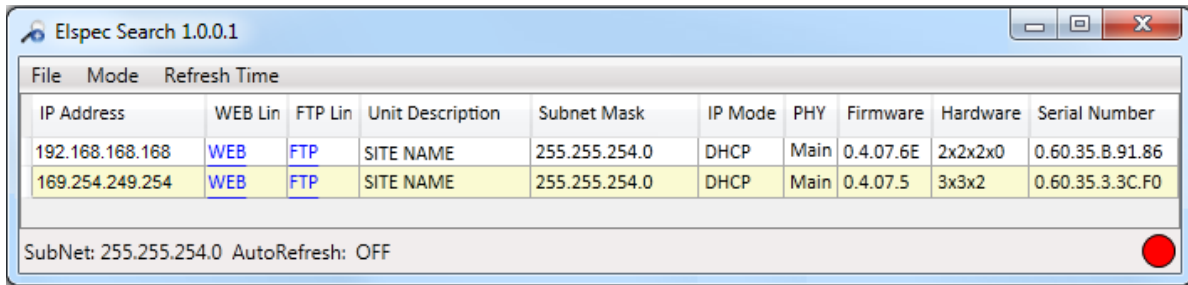

IP Address	WEB Lin	FTP Lin	Unit Description	Subnet Mask	IP Mode	PHY	Firmware	Hardware	Serial Number
192.168.168.168	WEB	FTP	SITE NAME	255.255.254.0	DHCP	Main	0.4.07.6E	2x2x2x0	0.60.35.B.91.86
169.254.249.254	WEB	FTP	SITE NAME	255.255.254.0	DHCP	Main	0.4.07.5	3x3x2	0.60.35.3.3C.F0

SubNet: 255.255.254.0 AutoRefresh: OFF

Access instrument via the web hyperlink (Recommended):

- Select the **Web** link for your device, Elspec's Web Interface will now open:



- In order to view the different languages in the Web Interface, you will need to upload the language feature from [Elspec's Website](#) when installing your new Firmware. Once uploaded, simply select the applicable interface language from the drop-down list:



- The supported languages are:
 - English (Default)
 - Chinese
 - Czech
 - German
 - French
 - Russian
 - Spanish

(For other languages - please contact your local Elspec distributor)

- The Password field defines user level/privileges. The user levels are **Viewer / Administrator** (See Security Settings). The default password including privileges for each level are:
 - Viewer is **123** (Read only, can choose interface language only, no operations related changes are allowed)
 - Administrator is **12345** (Administration, setup & full control)

NOTE NOTE NOTE

- The Website is optimized to work with Internet Explorer 7, 8 or 9 in “Compatibility View”. Ensure that the Internet Explorer is running in **Compatibility View**:



Other web browser applications can limit some functionality and/or show an incorrect layout.

- For local networking the browser should be configured as working without a proxy server. Refer to Disable Proxy Server in Internet Explorer.
- Should you be running Skype simultaneously with Elspec’s Search, you will not be able to access the device via the Web Link. Close Skype & access Elspec’s Search again to follow the Web Link.
- The passwords above are factory default values. You are advised to modify Admin password if extended security measures are required (See Security Settings).

direct instrument access via internet explorer:

Access the device by typing the BLACKBOX's IP address in the address field in Internet Explorer:

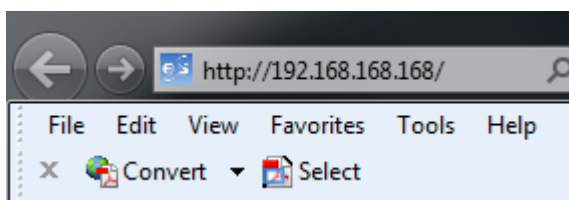

- Choose the language & enter the password as outlined above

see also:

- [About Quick Installation](#)
- [Unit Powering](#)
- [About Portable Wiring](#)
- [Plug and Play Voltage & Current Probes](#)
- [Grounding](#)
- [Establish 1st Time Connection](#)
- [About Quick Configuration](#)
- [Verify Measurement Readings](#)
- [Enable PQZIP Recording](#)

About Quick Unit Configuration

This section focuses only on the major configurations needed for initial installation of your Portable BLACKBOX device. Configurations are done via [Elspec's Web Interface](#). For a more detailed & comprehensive procedure see Instrument Settings. This procedure includes a quick & simple configuration procedure for your:

- [Portable BLACKBOX Unit](#)
- [Voltage & Frequency](#)
- [Currents](#)

see also:

- [About Quick Installation](#)
- [Unit Powering](#)
- [About Portable Wiring](#)
- [Plug and Play Voltage & Current Probes](#)
- [Grounding](#)
- [Establish 1st Time Connection](#)
- [Unit Access](#)
- [Verify Measurement Readings](#)
- [Enable PQZIP Recording](#)

Quick Unit Configuration

- After you have [Plugged in your Device](#), you will need to configure the unit itself. [Access](#) your Portable Device via [Elspec's Web Interface](#) ➔ log on as the **Administrator** ➔ under **Configuration** ➔ **Device Setup** select the **Device Info** Tab:

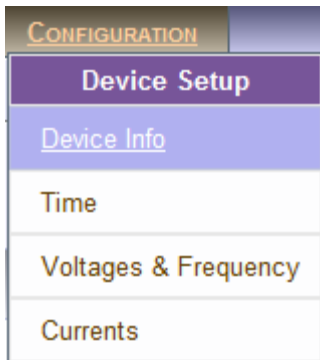

- In the **G4 Unit Configuration** Section complete:
 - Site Name:** Enables the user to define a description of the site where the device is installed. This site description also appears in the Elspec's Search utility under Unit Description when searching for devices
 - Description:** An additional text field for you to use optionally as you see fit
 - Operator:** A text field typically for inputting operator/technician name
 - Company:** A text field typically for inputting company name

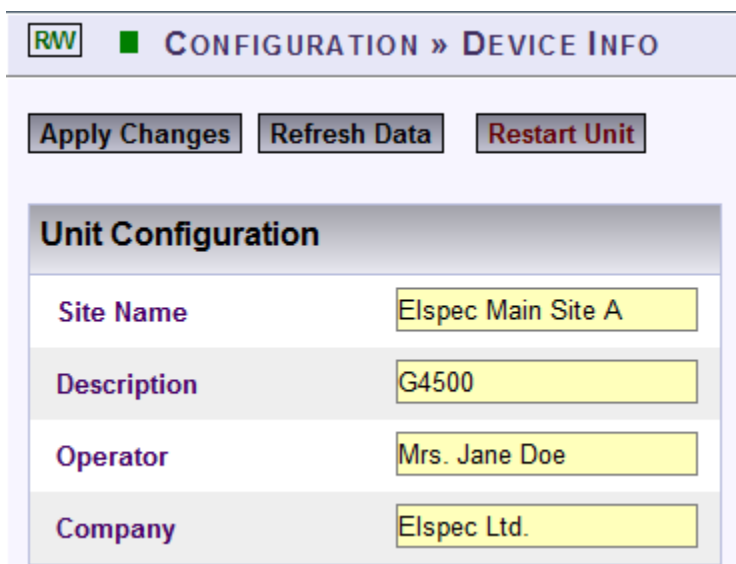

- To apply your changes select [Apply Changes](#). A success message will confirm your changes:

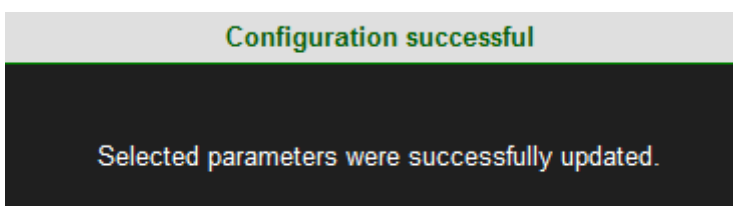

- To review your changes select [Refresh Data](#)

- Go to the next step [Configuring Voltage & Frequency](#)

NOTE NOTE NOTE

If you are not logged on as the Administrator, you will not be able to change any of these settings & you will receive the following error message in your attempt to do so:

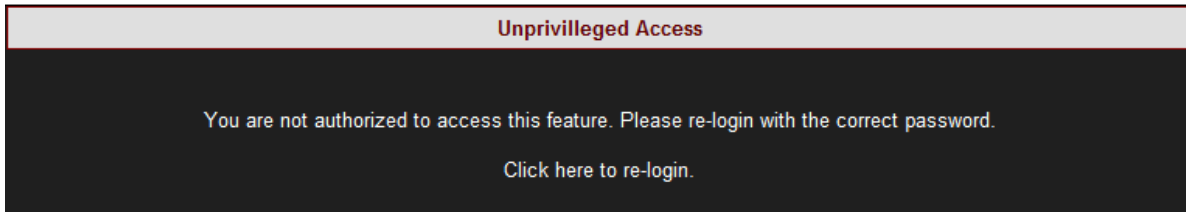

Once you have signed on at the Administrator ensure that you select [Apply Changes](#) to actually affect your changes.

see also:

- [About Quick Configuration](#)
- [Voltage & Frequency](#)
- [Currents](#)

Voltage & Frequency Configurations

As mentioned previously, after you have [Plugged in the Voltage Probes](#) it will be automatically recognized. Therefore, only minor configuration adjustments will need to be made in the **Voltage & Frequency Configuration Window**.

- [Access your Portable BLACKBOX Unit](#) via Elspec's Web Interface → log on as the Administrator → under Configuration → Device Setup select the **Voltage & Frequency Tab**:

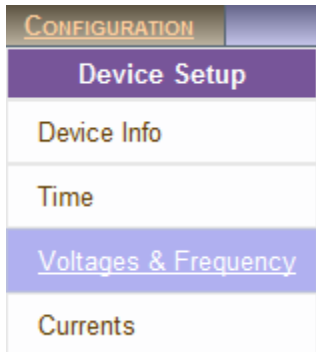

- In the **Voltage & Frequency Window**:

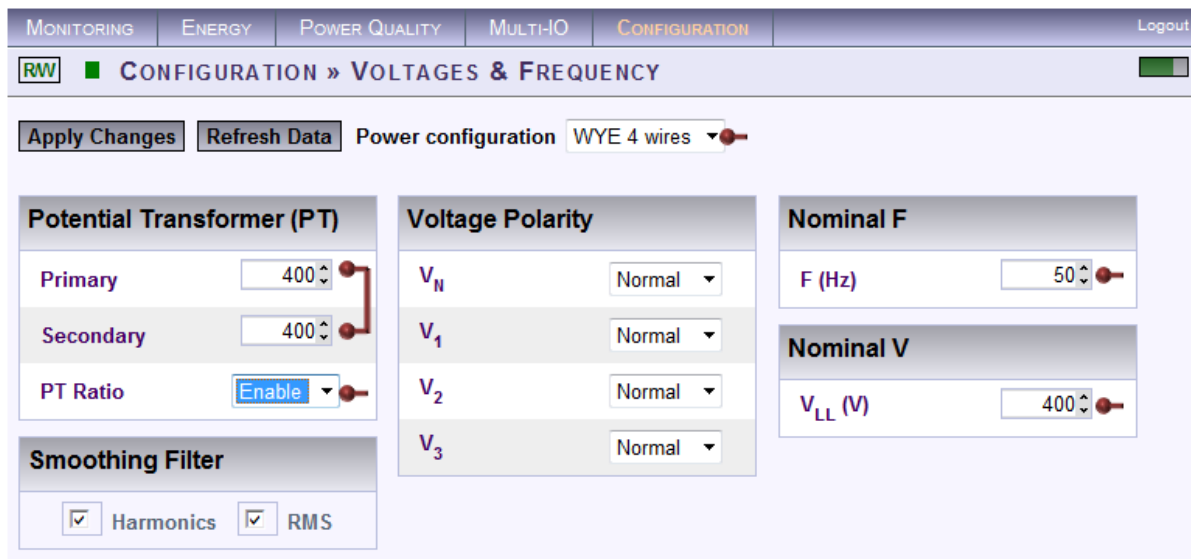

- Select the applicable **Network Type Settings** according to your Network Type from the drop-down selection:

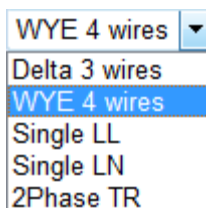

- If you wish to measure the Potential Transformer (MV/HV Networks - Voltage Measurements by PT's) select **Enable**:

PT Ratio	Disable ▾
	Disable
	Enable

- For MV/HV Networks (Voltage Measurements by PT's) set the correct **Primary & Secondary Ratio** (with /) - according to the **PT Manufacturer's Specifications & not just the Ratio**:

Potential Transformer (PT)	
Primary	400 ⇅
Secondary	400 ⇅

- Define the **Nominal Values** for Frequency (F) and Voltages (V) (with ▲/▼):

Nominal F	
F (Hz)	50 ⇅
Nominal V	
V_{LL} (V)	400 ⇅

- The ratio for LV Networks (<1kV) is based on the same concept & specifications:

<p>Set the Primary & Secondary Ratio (with /) -(according to the PT Manufacturer's Specifications & not just the Ratio):</p> <table border="1"> <thead> <tr> <th colspan="2">Potential Transformer (PT)</th> </tr> </thead> <tbody> <tr> <td>Primary</td> <td>5 ⇅</td> </tr> <tr> <td>Secondary</td> <td>1 ⇅</td> </tr> </tbody> </table>	Potential Transformer (PT)		Primary	5 ⇅	Secondary	1 ⇅	<p>Define the Nominal Values for Frequency (F) and Voltages (V) (with /):</p> <table border="1"> <thead> <tr> <th colspan="2">Nominal F</th> </tr> </thead> <tbody> <tr> <td>F (Hz)</td> <td>50 ⇅</td> </tr> </tbody> <thead> <tr> <th colspan="2">Nominal V</th> </tr> </thead> <tbody> <tr> <td>V_{LL} (V)</td> <td>230 ⇅</td> </tr> </tbody> </table>	Nominal F		F (Hz)	50 ⇅	Nominal V		V_{LL} (V)	230 ⇅
Potential Transformer (PT)															
Primary	5 ⇅														
Secondary	1 ⇅														
Nominal F															
F (Hz)	50 ⇅														
Nominal V															
V_{LL} (V)	230 ⇅														

- To apply your changes select **Apply Changes** ➔ **Refresh Data** to review your changes
- Go to the next step [Current Configuration](#)

NOTE NOTE NOTE

If you are not logged on as the Administrator, you will not be able to change any of these settings & you will receive the following error message in your attempt to do so:

Unprivileged Access
You are not authorized to access this feature. Please re-login with the correct password. Click here to re-login.

Once you have signed on at the Administrator ensure that you select **Apply Changes** to actually affect your changes.

Leakage Voltage

A designated PQZIP channel for calculated leakage voltage

Note:

- i. The default nominal value of V5 equals 2.3V i.e., 1% of 230V.
- ii. Changing the Nominal value of V5 can only be made through editing the unit's configuration file.

see also:

- [About Quick Configuration](#)
- [Unit Configuration](#)
- [Currents](#)

Currents

As mentioned previously, after you have [Plugged in your Current Probes](#) it will be automatically recognized. Therefore, only minor configuration adjustments will need to be made in the **Current Configuration Window**. Elspec supplies a complete range of Clamps with the Portable BLACKBOX that are divided into two categories: Custom Clamps & all other Clamps - See [Optional Accessories](#).

The Custom clamps are capable of measuring currents up to 3000 Amps at very high frequencies of 10 kHz. The probes provide a linear voltage output replicating input current waveform ranges of either 30, 300, or 3000 Amperes. The Ampere setting is controlled & set by the user via a Rotary-Switch. Due to the nature of this setting, the Hardware range needs to be configured accordingly in the unit's Web Interface. As such, the configurations differ for the two different groups of Clamps -

- [Access your Portable BLACKBOX Unit](#) via Elspec's Web Interface ➡ log on as the Administrator ➡ under Configuration ➡ Device Setup select the Currents Tab:

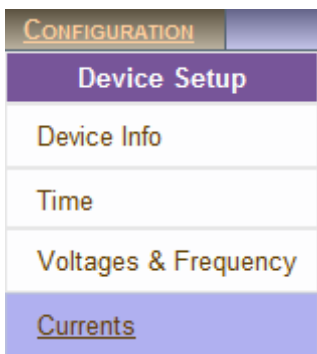

- As mentioned all the connected clamps will be automatically recognized. Adjust the **Currents Probe Info** in the applicable sections:
 - **Primary & Secondary Transformation Ratios** for all the Current channels;
 - **Nominal Ampere Values** for all the Current Channels (Nominal is set for the current measurements that will define PQZIP threshold / tolerance value & it is also used for event settings);
 - Either **Reverse the Polarity** / maintain it at **Normal** from the drop-down selection (Polarity toggling is used to correct incorrect wiring);
 - Clamp's **Current / Voltage Ratio** as per the **Clamp's Rotary Current Setting** - use the table below as your guide:

CLAMP ROTARY CURRENT SETTING	I/V Ratio
30A	100 mVA
300A	10 mVA
3000A	1 mVA

- The Hardware Range as per the Clamp's Rotary Current Setting - use the table below as your guide:

CLAMP ROTARY CURRENT SETTING	HARDWARE RANGE
30A	70.710678A
300A	707.10678A
3000A	7071.0678A

The screenshot displays the 'CONFIGURATION » CURRENTS' page in the ELSPEC G4500 BLACKBOX software. It includes sections for 'Current Probes Info', 'Custom/DC probes Info', and 'Non-measured Currents'.

Current Probes Info

Channel	CT Ratio (A)		Nominal (A)	Polarity	Clamp Info	Behavior simulation
	Primary	Secondary				
I ₁	3000	3000	3000	Normal	Custom clamp I ₁	No Simulation
I ₂	300	300	300	Normal	Custom clamp I ₂	No Simulation
I ₃	30	30	30	Normal	Custom clamp I ₃	No Simulation
I _N	---	---	---	Normal	No Probe Detected	No Simulation
I ₅	50	50	50	Normal	Custom clamp I ₅	No Simulation

Custom/DC probes Info

Clamp Info	I/V Ratio		Hardware Range
	Current	Voltage	
Custom clamp I ₁	1	0.1	70.710678 A
Custom clamp I ₂	1	0.01	707.10678 A
Custom clamp I ₃	1	0.001	7071.0678 A
Custom clamp I ₅	1	0.01	2144.047363 A

Non-measured Currents

Calculated Phase: All Present

Use I₅ for: Physical input current / Calculated leakage current

Leakage Current

A designated channel is used for leakage current in one of the following manners

- i. Calculated channel
- ii. Physical channel measured via IDC channel of a portable unit

Note: I₅ nominal value should be configured to suit the expected leakage current value which is usually a fraction of the nominal phase current.

I₅ should be configured according to the mode of work i.e., physical leakage measurement or calculated leakage as illustrated below.

Non-measured Currents	
Calculated Phase	All Present <input type="button" value="v"/>
Use I ₅ for	<input type="button" value="Physical input current"/> <input type="button" value="Calculated leakage current"/>

- To apply your changes select **Apply Changes** ➔ **Refresh Data** to review your changes; For more on the Custom Clamp’s Specifications, See [Optional Accessories](#).

Currents Configuration - Other Elspec Clamps:

- [Access your Portable BLACKBOX Unit](#) via Elspec's Web Interface ➔ log on as the Administrator ➔ under Configuration ➔ Device Setup select the Currents Tab:

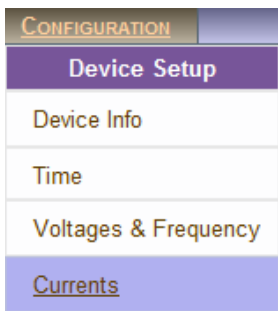

- As mentioned all the connected clamps will be automatically recognized. Adjust the **Currents Probe Info** in the applicable sections:
 - Primary & Secondary Transformation Ratios** for all the Current channels (As per Clamp's individual Specifications);
 - Nominal Ampere Values** for all the Current Channels (Nominal is set for the current measurements that will define PQZIP threshold / tolerance value & it is also used for event settings);
 - Either **Reverse** the **Polarity** / maintain it at **Normal** from the drop-down selection (Polarity toggling is used to correct incorrect wiring)
 - The **Behavior Simulation** may be reversed 300/3000A Flexible Clamp. Ensure that you adjust the CT Ratio accordingly;
 - The **Hardware Range** is only applicable for the DC & Custom Clamps. This is adjust according to the Clamp's individual Specifications - See [Optional Accessories](#):

Current Probes Info

Channel	CT Ratio (A)		Nominal (A)	Polarity	Clamp Info	Behavior simulation
	Primary	Secondary				
I ₁	100	100	100	Normal	Mini 100A:1A/1mV	No Simulation
I ₂	3000	3000	3000	Normal	Flex clamp-3000A	No Simulation
I ₃	3000	3000	3000	Normal	Flex clamp-300A	Flex clamp-3000A
I _N	---	---	---	Normal	No Probe Detected	No Simulation
I ₅	1	1	1	Normal	Mini 1-5A:1A/1V	No Simulation

Custom/DC probes Info

Clamp Info	I/V Ratio		Hardware Range
	Current	Voltage	

Non-measured Currents

Calculated Phase: All Present

Use I₅ for: Physical input current

Leakage Current

A designated channel is used for leakage current in one of the following manners

- i. Calculated channel
- ii. Physical channel measured via IDC channel of a portable unit
 - Note:** I₅ nominal value should be configured to suit the expected leakage current value which is usually a fraction of the nominal phase current.

I₅ should be configured according to the mode of work i.e., physical leakage measurement or calculated leakage as illustrated below.

Non-measured Currents	
Calculated Phase	All Present <input type="button" value="v"/>
Use I ₅ for	<input type="button" value="Physical input current"/> <input type="button" value="Calculated leakage current"/>

- To apply your changes select → to review your changes;

NOTE NOTE NOTE

If you are not logged on as the Administrator, you will not be able to change any of these settings & you will receive the following error message in your attempt to do so:

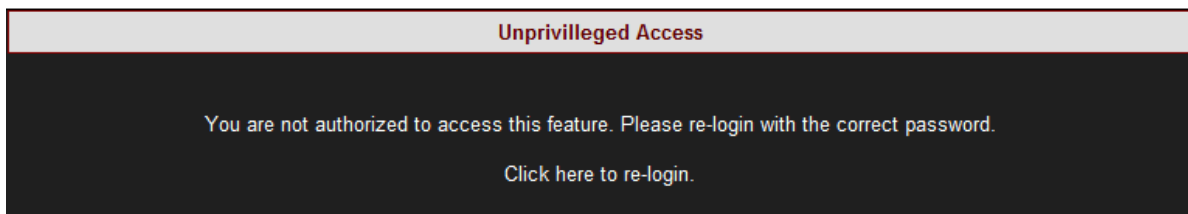

Once you have signed on at the Administrator ensure that you select to actually affect your changes.

see also:

- [About Quick Configuration](#)
- [Unit Configuration](#)
- [Voltage & Frequency](#)

About Verifying Measurement Readings

The final step after you have [Configured your Device](#), is to verify the voltage & current measurements of your Portable BLACKBOX. This verification step covers only a partial section of the BLACKBOX's Full PQ Monitoring Capabilities. It includes:

- [Accessing & Reviewing the Measurement Summary](#)
- [Accessing & Reviewing Voltage & Current Measurements](#)
- [Accessing & Reviewing the Power](#)

see also:

- [Quick Installation](#)
- [Unit Powering](#)
- [Establish 1st Time Connection](#)
- [Plug & Play - Voltage & Current Probes](#)
- [Unit Access](#)
- [Quick Unit Configuration](#)
- [Enable PQZIP Recording](#)

Access the Measurement Summary

The Measurement Summary summarizes all your measurement readings. The most important parameters you will need to focus on in this window are **Phase Order (for 3 phase systems) & DSP Synchronization**:

- **Phase Order:** Confirms the order of the voltage phases starts from V_1 & are moving in a clockwise direction
- **DSP Synchronization:** Confirms that the unit is synchronized with the network
- For a full description on all the definitions & subsequent parameter calculations see PQ Monitoring

ACCESS THE SUMMARY WINDOW

- [Access your Portable BLACKBOX Unit](#) via the Web Interface ➔ Open Monitoring

➔ Summary:

MONITORING	ENERGY	POWER QUALITY
Summary	V & I harmonics	
Voltage & Current	P & Q harmonics	
Average	Spectrum	
Power	Harmonics Table	
Temperature	V/I Min/Max Harmonics	
Phasors	P/Q Min/Max Harmonics	
Waveforms		
Voltage Flickering		
Pinst Waveform		
Min/Max Flickering		

- The Summary Window will now open:

Summary	
Frequency	50.002 Hz
I_{avg}	0.0000 A
$V(LL)_{avg}$	0.0371 V
$V(LN)_{avg}$	1.4222 V
Power factor _{total}	0.6667 (Ind)
Phase Order	123
Synchronization Status	
Time Synchronization	Main Moderate
DSP Synchronization	On

see also:

- [About Measurement Readings](#)
- [Verify Voltage & Current](#)
- [Verify Power](#)

Verify Voltage & Current Readings

This page displays specific values as per the parameters configured for [Voltage & Current](#) for your G4500/G3500 Unit. For a full description on all the definitions & subsequent parameter calculations see Voltage & Current.

- [Access your Portable BLACKBOX Unit](#) via the Web Interface ➔ **Open Monitoring**
 ➔ **Voltage & Current:**

MONITORING	ENERGY	POWER QUALITY
Summary		V & I harmonics
Voltage & Current		P & Q harmonics
Average		Spectrum
Power		Harmonics Table
Temperature		V/I Min/Max Harmonics
Phasors		P/Q Min/Max Harmonics
Waveforms		
Voltage Flickering		
Pinst Waveform		
Min/Max Flickering		

- Verify that the **RMS** values are as expected for both **Voltage & Current** are as per your Configurations:

MONITORING » VOLTAGE & CURRENT						
V/I <input type="checkbox"/> PU						
	RMS	Min Value	Max Value	THD	Crest Factor	K Factor
V ₁	1.4231 V	1.3982 V	230.67 V	6.8858 %	1.9276	---
V ₂	1.4215 V	1.3983 V	229.43 V	6.9813 %	1.5061	---
V ₃	1.4277 V	1.4037 V	230.67 V	6.8337 %	1.9216	---
V _N	0.2064 V	0.1398 V	0.2833 V	----	----	---
V ₁₂	0.0451 V	0.0382 V	1.2344 V	----	----	---
V ₂₃	0.0449 V	0.0379 V	1.2347 V	----	----	---
V ₃₁	0.0224 V	0.0117 V	0.0249 V	----	----	---
I ₁	0.0000 A	0.0000 A	49.982 A	----	----	----
I ₂	0.0000 A	0.0000 A	1.6611 kA	----	----	----
I ₃	0.0000 A	0.0000 A	46.349 kA	----	----	----
I _N	0.0789 A	0.0000 A	21.106 A	6.0762 %	35.674	1.2583
I ₅	0.0794 A	0.0000 A	75.190 A	5.8634 %	35.563	1.0700

- Should the values be incorrect, recheck the PT/CT Ratios as well as the power source, [Voltage & Current Probe Connections](#).
- Go to the next step - [Verifying your Power](#) in order to verify that the **Active Power** readings are based on your [Current Configurations](#)

see also:

- [About Measurement Readings](#)
- [Access Measurement Summary](#)
- [Verify Power](#)

Verify Power Readings

Although Power Configurations is comprehensively dealt with in the Power Section, this section is necessary to verify that all the **Active Power** readings reflect **Positive Values**. Corrections can be made by toggling the polarity in the [Current Configurations](#).

For a full description on all the configurations, definitions & subsequent parameter calculations see Power.

- Access your Portable BLACKBOX Unit via the Web Interface → Open Monitoring → Power:

MONITORING	ENERGY	POWER QUALITY
Summary		V & I harmonics
Voltage & Current		P & Q harmonics
Average		Spectrum
Power		Harmonics Table
Temperature		V/I Min/Max Harmonics
Phasors		P/Q Min/Max Harmonics
Waveforms		
Voltage Flickering		
Pinst Waveform		
Min/Max Flickering		

- Verify that the **Active Power** readings reflect **Positive Values**:

MONITORING » POWER			CONFIGURATION » CURRENTS				
Power Summary			Current Probes Info				
	Active Power	Reactive Power	Channel	CT Ratio (A)		Nominal (A)	Polarity
Phase1	51.375 kW	-32.354 kVAr	I ₁	---	---	---	Normal
Phase2	26.294 kW	13.854 kVAr	I ₂	---	---	---	Normal
Phase3	-0.0589 kW	0.0025 kVAr	I ₃	100	100	100	Reverse
Neutral	0.0000 kW	0.0000 kVAr	I _N	300	300	300	Normal
Total	77.610 kW	-18.497 kVAr	I ₅	1	1	0.5	Normal

- Should any of the **Phase Integers** display a negative value (as per the highlighted section above) you will need to **Reverse** the **Polarity** for the **Phase** in the [Current Configurations](#). Alternatively you may also physically reverse the current clamp at the power source, by changing the direction. Generators commonly display a negative Active Power value.

see also:

- [About Measurement Readings](#)
- [Access Measurement Summary](#)
- [Verify Voltage & Current](#)

Enabling PQZIP Recording

In order to record actual data for further analysis by PQSCADA & Investigator, you must first enable the PQZIP Recording.

HOW TO ENABLE PQZIP RECORDING

- [Access your Portable BLACKBOX Unit](#) via the Web Interface ➔ Open Configuration ➔ PQZIP Recording
- In the **State** drop-down selection select **Enable**:

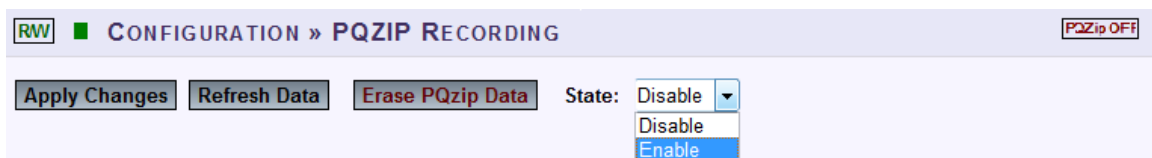

- To apply your changes select **Apply Changes**
- The following warning may appear if some parameter readings are inconsistent with the configuration. In this case make sure all parameters are correct before enabling the PQZIP:

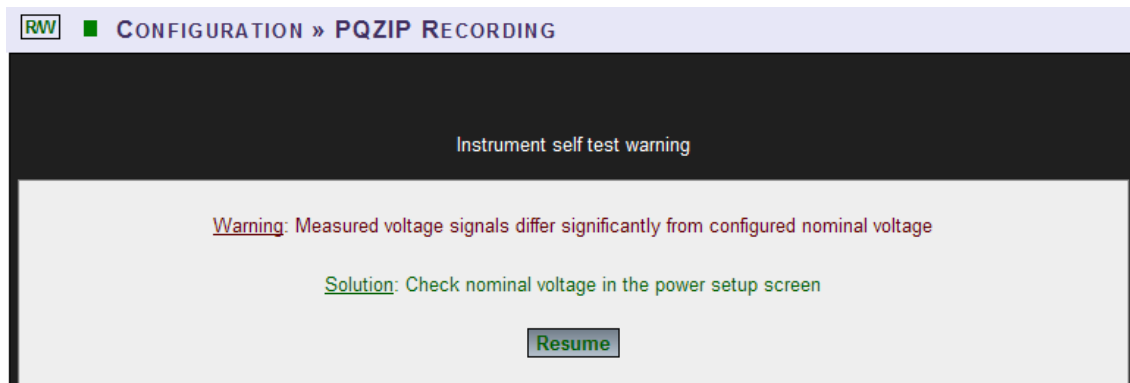

- Confirm by selecting **Resume** & the following success message will appear:

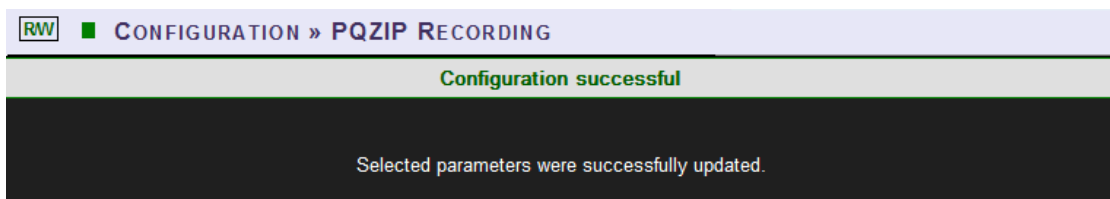

- To view your changes (refresh your current view) select **Refresh Data**

NOTE NOTE NOTE

- If you are not logged on as the Administrator, you will not be able to change any of these settings & you will receive the following error message in your attempt to do so:

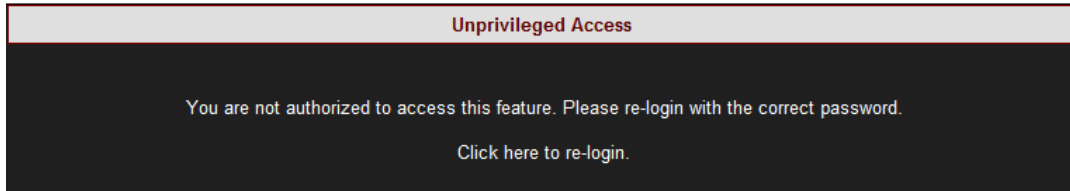

- Once you have signed on at the Administrator ensure that you select **Apply Changes** to actually affect your changes.
- Once you have enabled the PQZIP recording, the PQZIP OFF Icon will no longer appear on the right-hand side on this & any other screen:



see also:

- [About Quick Installation](#)
- [Unit Powering](#)
- [About Portable Wiring](#)
- [Plug and Play Voltage & Current Probes](#)
- [Grounding](#)
- [Establish 1st Time Connection](#)
- [Unit Access](#)
- [About Quick Configuration](#)
- [Verify Measurement Readings](#)

About Monitoring Real Time Data

The Monitoring section displays real time readings and graphs of the grid's parameters. The graph display requires an ActiveX plug-in from Gigasoft that is downloadable either from [Elspec's Website's Support Section](#) or alternatively can be installed directly from your BLACKBOX CD. The ActiveX plug-in allows different view options needed for your PQ Monitoring. In the PQ Monitoring Section you will be able to monitor the following PQ measurements of your Portable BLACKBOX:

- Total measurements in the Summary Window
- [Voltage & Current Measurements](#)
- [Average Measurements](#)
- [Power Measurements](#)
- [Internal & External Temperature Readings](#)
- [Voltage & Current Phase Diagrams](#)
- [Voltage & Current Waveforms](#)
- [Short & Long Term Voltage Flickering](#)
- [Flickering Waveforms](#)
- [Minimum & Maximum Flickering Values](#)
- [Voltage & Current Harmonics Spectrum](#)
- [Active & Reactive Harmonic Powers](#)
- [Voltage & Current Sub & Inter-Harmonics](#)
- [Voltage & Current Harmonics in Values, %'s & Angles](#)
- [Minimum, Maximum Values & Angles of Voltage & Current Harmonics](#)
- [Minimum & Maximum Values of Active & Reactive Power Harmonics](#)

Access the PQ monitoring summary:

- Access your **Portable BLACKBOX Unit** via the Web Interface → Open **Monitoring** → **Summary**:

MONITORING	ENERGY	POWER QUALITY
Summary	V & I harmonics	
Voltage & Current	P & Q harmonics	
Average	Spectrum	
Power	Harmonics Table	
Temperature	V/I Min/Max Harmonics	
Phasors	P/Q Min/Max Harmonics	
Waveforms		
Voltage Flickering		
Pinst Waveform		
Min/Max Flickering		

- The **Summary & Synchronization Status Window** will now open:

MONITORING » SUMMARY		
Summary <input type="checkbox"/> PU		
Frequency	50.002 Hz	
I_{avg}	0.0114 A	
$V(LL)_{avg}$	0.0421 V	
$V(LN)_{avg}$	1.2997 V	
Power factor_{total}	0.0736 (Ind)	
Phase Order	123	
Synchronization Status		
Time Synchronization	Main	Good
DSP Synchronization	On	

TABLE - PQ calculation method:

The table outlines the sections' Parameters including definitions:

Parameter	Definition
SUMMARY WINDOW	
Frequency	The number of cycles per second
I_{AVG}	The current in a single phase system or the current averaged over all three phases in a three phase system
$V(LL)_{AVG}$	Line to line voltage averaged over all three phases in a three phase system
$V(LN)_{AVG}$	Line to neutral voltage averaged over the three phases
Power Factor _{TOTAL}	Total True Power Factor over three phases, averaged by default over 1 minute
Phase Order	The order of the voltage phases starting from V_1 moving in a clockwise direction
SYNCHRONIZATION STATUS	
Time Synchronization	Indicates the connection quality to the time source. This connection supplies the instrument with world time (UTC) from a time source. The Time Sync quality is essential to PQZIP coherent file generation
DSP Synchronization	The unit is synchronized with the signals of the device

Voltage & Current Measurements

This page displays specific values for Voltage & Current Measurements. The viewed parameters depend on how your Portable BLACKBOX Unit has been Configured.

- [Access your Portable BLACKBOX Unit](#) via the Web Interface ➔ select **Monitoring** ➔ **Voltage & Current:**

MONITORING	ENERGY	POWER QUALITY
Summary		V & I harmonics
Voltage & Current		P & Q harmonics
Average		Spectrum
Power		Harmonics Table
Temperature		V/I Min/Max Harmonics
Phasors		P/Q Min/Max Harmonics
Waveforms		
Voltage Flickering		
Pinst Waveform		
Min/Max Flickering		

- The Voltage & Current PQ Monitoring Window will now open

Voltage & Current section (rms, min/max value, thd, crest factor, k factor):

V/I ☐ PU						
	RMS	Min Value	Max Value	THD	Crest Factor	K Factor
V ₁	1.4231 V	1.3982 V	230.67 V	6.8858 %	1.9276	---
V ₂	1.4215 V	1.3983 V	229.43 V	6.9813 %	1.5061	---
V ₃	1.4277 V	1.4037 V	230.67 V	6.8337 %	1.9216	---
V _N	0.2064 V	0.1398 V	0.2833 V	----	----	---
V ₁₂	0.0451 V	0.0382 V	1.2344 V	----	----	---
V ₂₃	0.0449 V	0.0379 V	1.2347 V	----	----	---
V ₃₁	0.0224 V	0.0117 V	0.0249 V	----	----	---
I ₁	0.0000 A	0.0000 A	49.982 A	----	----	----
I ₂	0.0000 A	0.0000 A	1.6611 kA	----	----	----
I ₃	0.0000 A	0.0000 A	46.349 kA	----	----	----
I _N	0.0789 A	0.0000 A	21.106 A	6.0762 %	35.674	1.2583
I ₅	0.0794 A	0.0000 A	75.190 A	5.8634 %	35.563	1.0700

table - Voltage & Current section (rms, min/max value, thd, crest factor, k factor) calculation method:

Parameter	Definition
PU	By selecting PU (Per Unit) will present the values as part of nominal (for example: 230V ➔ 100.0%)
VRMS	$V_{RMS_x} = \sqrt{\sum_{n=1} ((V \cos \varphi)^2 + (V \sin \varphi)^2)}$ <p>n = Number of Samples</p> <p>x = Specific Channel</p> <p>10/12 Continuous Non-Overlapping Cycles Accordance with IEC61000-4-30</p> <p style="text-align: right;">In</p>
ARMS	$I_{RMS_x} = \sqrt{\sum_{n=1} ((I \cos \varphi)^2 + (I \sin \varphi)^2)}$ <p>n = Number of Samples</p> <p>x = Specific Channel</p> <p>10/12 Continuous Non-Overlapping Cycles Accordance with IEC61000-4-30</p> <p style="text-align: right;">In</p>
Min Value	Minimum RMS value since the initial power up or the most recent selection of: Reset All Min/Max
Max Value	Maximum RMS value since the initial power up or the most recent selection of: Reset All Min/Max
THD	$\sqrt{\frac{\sum_{n=2}^{50} C_n^2}{C_1^2}}$ <p>C = Harmonic RMS Value</p> <p>n = Harmonic Order</p>

Parameter	Definition
V Crest Factor	$\frac{V_{PEAK}}{V_{RMS}}$ <p>Measures Ratio Between the VPEAK and VRMS</p>
A Crest Factor	$\frac{I_{peak}}{I_{RMS}}$ <p>Measures Ratio Between the IPEAK and IRMS</p>
K Factor	$\frac{\sum_{n=1}^{25} (i_n * n)^2}{\sum_{n=1}^{25} i_n^2}$ <p>Where n is the Harmonic #, and i_n is the RMS value of the n^{TH} Harmonic</p>

Voltage & Current section (tdd, thd eVEN, thd ODD, OVER-DEVIATION, UNDER DEVIATION):

VII					
	TDD	THD Even	THD Odd	Over-deviation	Under-deviation
V ₁	---	1.7418 %	6.6401 %	230.94 V	1.4234 V
V ₂	---	1.4148 %	6.9192 %	230.94 V	1.4231 V
V ₃	---	1.6601 %	6.5897 %	230.94 V	1.4287 V
V _N	---	----	----	230.94 V	0.2043 V
V ₁₂	---	----	----	400.00 V	0.0447 V
V ₂₃	---	----	----	400.00 V	0.0447 V
V ₃₁	---	----	----	400.00 V	0.0225 V
I ₁	----	----	----	---	---
I ₂	----	----	----	---	---
I ₃	----	----	----	---	---
I _N	4.1911 %	4.0172 %	5.0738 %	---	---
I ₅	6.0551 %	3.9180 %	4.2431 %	---	---

table voltage & Current section (tdd, thd eVEN, thd ODD, OVER-DEVIATION, UNDER DEVIATION) calculation method:

Parameter	Definition
TDD	<p>Total Demand Distortion - TDD - is the current distortion (harmonics above the 1st) as a percent of maximum demand load. TDD is defined using the following relationship:</p> $I_{TDD} = \sqrt{\sum_{h=2}^{\infty} \left[\frac{I_h^2}{I_L^2} \right]} * 100\%$
THD Even	$\sqrt{\frac{\sum_1^{25} C_{2n}^2}{C_1^2}}$ <p>C = Harmonic RMS Value n = Harmonic Order</p>
THD Odd	$\sqrt{\frac{\sum_1^{25} C_{2n+1}^2}{C_1^2}}$ <p>C = Harmonic RMS Value n = Harmonic Order</p>
Over-Deviation	The Over-Deviation indicates how much higher the RMS Voltage is than the Reference Voltage
Under-Deviation	The Under-Deviation indicates how much lower the RMS Voltage is than the Reference Voltage

unbalance section (avg, min, max):

Unbalance			
	Avg.	Min.	Max.
U ₋ Unbalance	123.90 %	0.5155 %	4227.8 %
U ₊ Positive Sequence	0.0020 V	0.0000 V	0.6441 V
U ₋ Negative Sequence	0.0025 V	0.0000 V	0.6333 V
U ₀ Sequence	2.0041 V	0.1559 V	327.24 V
u ₀ Zero sequence ratio	98272 %	8984.5 %	***
i ₋ Unbalance	----	----	----
i ₊ Positive Sequence	----	----	----
i ₋ Negative Sequence	----	----	----
i ₀ Zero sequence	----	----	----
i ₀ Zero sequence ratio	----	----	----

table - unbalance section (Avg, Min, Max) parameters calculation method:

The table outlines the sections' Parameters including Calculation:

Parameter	Definition
Unbalance	The Supply Voltage Unbalance is Evaluated Using the Method of Symmetrical Components in Accordance with IEC61000-4-30
Unbalance Avg.	The Average Supply Voltage Unbalance is Evaluated Using the Method of Symmetrical Components in Accordance with IEC61000-4-30
Unbalance Min.	The Minimum Supply Voltage Unbalance is Evaluated Using the Method of Symmetrical Components in Accordance with IEC61000-4-30
Unbalance Max.	The Maximum Supply Voltage Unbalance is Evaluated Using the Method of Symmetrical Components in Accordance with IEC61000-4-30
Zero Sequence Unbalance	$U_0 = \left \frac{u_0}{u_1} \right * 100$
Negative Sequence Unbalance	$U_2 = \left \frac{u_2}{u_1} \right * 100$
Positive Sequence	<p>Defined as the symmetrical vector system derived by application of the Fortescue's transformation matrix, and that rotates in the same direction as the power frequency voltage (or current):</p> $\underline{U}_1 = \frac{1}{3} (\underline{U}_a + a \cdot \underline{U}_b + a^2 \cdot \underline{U}_c)$ <p>where $a = 1\angle 120^\circ = -\frac{1}{2} + j\frac{\sqrt{3}}{2}$ and $\underline{U}_a, \underline{U}_b, \underline{U}_c$ and are line to neutral voltages (fundamental component)</p> <p>In Accordance With IEC61000-3-13, ed. 1.0 (2008-02) Ref: 3.26.3</p>
Negative Sequence	<p>Defined as the symmetrical vector system derived by application of the Fortescue's transformation matrix, and that rotates in the opposite direction to the power frequency voltage (or current):</p> $\underline{U}_1 = \frac{1}{3} (\underline{U}_a + a^2 \cdot \underline{U}_b + a \cdot \underline{U}_c)$ <p>where $a = 1\angle 120^\circ = -\frac{1}{2} + j\frac{\sqrt{3}}{2}$ and $\underline{U}_a, \underline{U}_b, \underline{U}_c$ and are line to neutral voltages (fundamental component)</p> <p>In Accordance With IEC61000-3-13, ed. 1.0 (2008-02) Ref: 3.26.4</p>
Zero Sequence	<p>Defined as the in-phase symmetrical vector system derived by application of the Fortescue's transformation matrix:</p> $\underline{U}_0 = \frac{1}{3} (\underline{U}_a + \underline{U}_b + \underline{U}_c)$ <p>where $\underline{U}_a, \underline{U}_b, \underline{U}_c$ and are line to neutral voltages (fundamental component)</p> <p>In Accordance With IEC61000-3-13, ed. 1.0 (2008-02) Ref: 3.26.5</p>

DC VOLTAGE & CURRENT SECTION (rms, Min, Max):

DC V/I			
	RMS	Min Value	Max Value
V_{DC}	0.5273 V	-0.5273 V	0.5273 V
I_{DC}	2.7393 A	-611.00 A	1.5670 kA

table - DC VOLTAGE & CURRENT SECTION (rms, Min, Max) parameters calculation method:

The table outlines the sections' Parameters including Calculation:

Parameter	Definition
DC Voltage & Current RMS	RMS-DC is the Root Mean Square of the DC component of the signal
DC Voltage & Current Min.	Minimum RMS value since the initial power up or the most recent selection of: Reset All Min/Max
DC Voltage & Current Max.	Maximum RMS value since the initial power up or the most recent selection of: Reset All Min/Max

see also:

- [About PQ Monitoring](#)
- [Averaging](#)
- [Power](#)
- [Temperature](#)
- [Phasors](#)
- [Waveforms](#)
- [Voltage Flickering](#)
- [Pinst Waveforms](#)
- [Min/Max Flickering](#)
- [Voltage & Current Harmonics](#)
- [PQ Harmonics](#)
- [Spectrum](#)
- [Harmonics Table](#)
- [V/I Min/Max Harmonics](#)
- [P/Q Min/Max Harmonics](#)

Average

In accordance to the IEC-61000-4-30 measurement standards, the Portable BLACKBOX displays the following Average Measurements: Aggregation of 150/180 cycles (3seconds); 10 minutes & 2 hours based at a Frequency of 10 minutes.

open the average window:

- [Access your Portable BLACKBOX Unit](#) via the Web Interface ➔ select **Monitoring**
➔ **Average:**

MONITORING	ENERGY	POWER QUALITY
Summary	V & I harmonics	
Voltage & Current	P & Q harmonics	
<u>Average</u>	Spectrum	
Power	Harmonics Table	
Temperature	V/I Min/Max Harmonics	
Phasors	P/Q Min/Max Harmonics	
Waveforms		
Voltage Flickering		
Pinst Waveform		
Min/Max Flickering		

- The Average Window will now open:

MONITORING » AVERAGE			
Frequency			
Frequency _{Over 10 sec}		50.002 Hz	
Averages			
	150/180 Cycles	10 Min.	2 Hours
Timestamp	25/12/2011 15:56:25	25/12/2011 15:50:00	DD/MM/YYYY HH:MM:SEC
Flag	Flagged: V1,V2,V3	Flagged: V1,V2,V3	Not flagged
V ₁	1.4311 V	1.4215 V	0.0000 V
V ₂	1.4310 V	1.4209 V	0.0000 V
V ₃	1.4366 V	1.4266 V	0.0000 V
V _N	0.2114 V	0.2054 V	0.0000 V
V ₁₂	0.0468 V	0.0473 V	0.0000 V
V ₂₃	0.0469 V	0.0476 V	0.0000 V
V ₃₁	0.0224 V	0.0217 V	0.0000 V
Under-deviation			
	150/180 Cycles	10 Min.	2 Hours
V ₁	99.380 %	99.384 %	0.0000 %
V ₂	99.381 %	99.385 %	0.0000 %
V ₃	99.378 %	99.382 %	0.0000 %
V _N	0.2114 %	99.911 %	0.0000 %
V ₁₂	99.987 %	99.988 %	0.0000 %
V ₂₃	99.987 %	99.988 %	0.0000 %
V ₃₁	99.994 %	99.995 %	0.0000 %
Over-deviation			
	150/180 Cycles	10 Min.	2 Hours
V ₁	0.0000 %	0.0000 %	0.0000 %
V ₂	0.0000 %	0.0000 %	0.0000 %
V ₃	0.0000 %	0.0000 %	0.0000 %
V _N	0.0000 %	0.0000 %	0.0000 %
V ₁₂	0.0000 %	0.0000 %	0.0000 %
V ₂₃	0.0000 %	0.0000 %	0.0000 %
V ₃₁	0.0000 %	0.0000 %	0.0000 %
Over-deviation			
	150/180 Cycles	10 Min.	2 Hours
V ₁	0.0000 %	0.0000 %	0.0000 %
V ₂	0.0000 %	0.0000 %	0.0000 %
V ₃	0.0000 %	0.0000 %	0.0000 %
V _N	0.0000 %	0.0000 %	0.0000 %
V ₁₂	0.0000 %	0.0000 %	0.0000 %
V ₂₃	0.0000 %	0.0000 %	0.0000 %
V ₃₁	0.0000 %	0.0000 %	0.0000 %
Unbalance			
	150/180 Cycles	10 Min.	2 Hours
u ₋ Unbalance	84.576 %	107.64 %	0.0000 %
U ₊ Positive Sequence	0.0030 V	0.0028 V	0.0000 V
U ₋ Negative Sequence	0.0022 V	0.0022 V	0.0000 V
U ₀ Sequence	1.8455 V	1.8429 V	0.0000 V
u ₀ Zero sequence ratio	67545 %	78179 %	0.0000 %
i ₋ Unbalance	100.000 %	100.01 %	0.0000 %
I ₊ Positive Sequence	0.0006 A	0.0013 A	0.0000 A
I ₋ Negative Sequence	0.0006 A	0.0013 A	0.0000 A
I ₀ Zero sequence	0.0006 A	0.0013 A	0.0000 A
i ₀ Zero sequence ratio	100.000 %	100.03 %	0.0000 %

table - average calculation method:

The table outlines the sections' Parameters including Definition:

Parameter	Definition
Frequency	Frequency - 10 seconds averaging
Average 150/180 Cycles	Average Measurements at an aggregation of 150/180 cycles (~3seconds)
Average 10 Min.	Average Measurements at an aggregation of 10 minutes
Average 2 Hours	Average Measurements at an aggregation of 2 hours
Under Deviation 150/180 Cycles	Displays how much lower the Average RMS Voltage is than the Reference Voltage at an aggregation of 150/180 cycles (~3seconds)
Under Deviation 10 Min.	Displays how much lower the Average RMS Voltage is than the Reference Voltage at an aggregation of 10 minutes
Under Deviation 2 Hours	Displays how much lower the Average RMS Voltage is than the Reference Voltage at an aggregation of 2 hours
Over Deviation 150/180 Cycles	Displays how much higher the Average RMS Voltage is than the Reference Voltage at an aggregation of 150/180 cycles (~3seconds)
Over Deviation 10 Min.	Displays how much higher the Average RMS Voltage is than the Reference Voltage at an aggregation of 10 minutes
Over Deviation 2 Hours	Displays how much higher the Average RMS Voltage is than the Reference Voltage at an aggregation of 2 hours
Unbalance 150/180 Cycles	<p>The Supply Voltage Unbalance is Evaluated Using the Method of Symmetrical Components in Accordance with IEC61000-4-30:</p> $Unbalance = \left[\frac{I_n}{I_p} \right] * 100$ <p>This entry displays the Average Maximum/Minimum Unbalanced Values at an aggregation of 150/180 cycles (~3seconds)</p>
Unbalance 10 Min.	This entry displays the Average Maximum/Minimum Unbalanced Values at an aggregation of 10 minutes
Unbalance 2 Hours	This entry displays the Average Maximum/Minimum Unbalanced Values at an aggregation of 2 hours

see also:

- [About PQ Monitoring](#)
- [Voltage & Current](#)
- [Power](#)
- [Temperature](#)
- [Phasors](#)
- [Waveforms](#)
- [Voltage Flickering](#)
- [Pinst Waveforms](#)
- [Min/Max Flickering](#)
- [V&I Harmonics](#)
- [P&Q Harmonics](#)
- [Spectrum](#)
- [Harmonics Table](#)
- [V/I Min/Max Harmonics](#)
- [P/Q Min/Max Harmonics](#)

Power

This page displays different electrical power parameters relevant to the Specific G4500/G3500 BLACKBOX Unit Configuration.

open the Power summary window:

- [Access your Portable BLACKBOX Unit](#) via the Web Interface → select **Monitoring**
→ **Power**:

MONITORING	ENERGY	POWER QUALITY
Summary		V & I harmonics
Voltage & Current		P & Q harmonics
Average		Spectrum
Power		Harmonics Table
Temperature		V/I Min/Max Harmonics
Phasors		P/Q Min/Max Harmonics
Waveforms		
Voltage Flickering		
Pinst Waveform		
Min/Max Flickering		

- The Power Summary Window will now open:

Power Summary					
	Active Power	Reactive Power	Apparent Power	True PF	Displacement PF
Phase1	14.478 kW	2.4813 kVAr	14.689 kVA	0.9856 (Ind)	0.9942 (Ind)
Phase2	14.823 kW	2.3731 kVAr	15.012 kVA	0.9874 (Ind)	0.9999 (Ind)
Phase3	10.906 kW	-2.1986 kVAr	11.126 kVA	0.9803 (Cap)	0.9931 (Cap)
Neutral	0.0000 kW	0.0000 kVAr	0.0000 kVA	0.0489 (Ind)	---
Total	40.207 kW	2.6558 kVAr	40.827 kVA	0.9848 (Ind)	0.9942 (Ind)

Should any of the **Phase Integers** display a negative value, you will need to **Reverse** the **Polarity** for the **Phase** in the [Current Configurations](#). Alternatively you may also physically reverse the current clamp at the power source, by changing the direction. Generators commonly display a negative Active Power value.

table - power calculation method:

The table outlines the sections' Parameters including Definition:

Parameter	Definition
Active Power	<p>The amount of Active Power consumed as usable energy. Sometimes referred to as Real Power. The portion of power flow that, averaged over a complete cycle of the AC waveform, results in the net transfer of energy in one direction expressed as kWh.</p> <p>Elspec calculates the Active Power accurately by taking all Harmonics up to the 40th into account using the following formula:</p> $P = \frac{1}{2} \sum_i V_{i,j} \cdot I_{i,j} \cdot \cos \theta_{i,j} \text{ [Watt]}$ <p>i = Harmonic j = Phase</p>
Reactive Power	<p>The amount of Reactive Power consumed as unusable energy. Energy that flows back and forth with no actual power flow. Reactive Power flow transfers no net energy to the load and is sometimes referred to as Wattless power. Elspec calculates reactive power using the following formula:</p> $Q = -P_q = - V I \sin\theta = -\vec{V} \times \vec{I} = \begin{vmatrix} \hat{i} & \hat{j} & \hat{k} \\ V_x & V_y & 0 \\ I_x & I_y & 0 \end{vmatrix} = \hat{k}(-V_x I_y + I_x V_y) \text{ [VAR]}$ <p>Elspec calculates the sign of Q using the following formula:</p> <p>Sign of Q = sign of: $\left(\sum_i (-V_{xi} \cdot I_{yi} + V_{yi} \cdot I_{xi}) \right)$</p>
Apparent Power	<p>The amount of Apparent Power; a vector addition of the Active and Reactive Power. The combination of active and reactive energy (kVAh)</p> <p>Elspec uses formula:</p> $S = V_{RMS} * I_{RMS} \text{ [VA]}$

PARAMETER	DEFINITION																									
True Power Factor (PF)	<p>The ratio between Real Power & Apparent Power (a value between 0 and 1). The most accurate measure of efficiency is the True Power Factor. It is defined as the sum of the P/S ratio over all the Harmonics:</p> $PF_{sign} = P_{sign} * Q_{sign}$ <p>if $PF_{sign} > 0$ than IND; $PF_{sign} < 0$ than CAP</p> <table border="1"> <thead> <tr> <th>QUADRAT</th> <th colspan="3"></th> <th>PF UNIT</th> </tr> </thead> <tbody> <tr> <td>I</td> <td>+</td> <td>+</td> <td>+</td> <td>IND</td> </tr> <tr> <td>II</td> <td>-</td> <td>+</td> <td>-</td> <td>CAP</td> </tr> <tr> <td>III</td> <td>-</td> <td>-</td> <td>+</td> <td>IND</td> </tr> <tr> <td>IV</td> <td>+</td> <td>-</td> <td>-</td> <td>CAP</td> </tr> </tbody> </table>	QUADRAT				PF UNIT	I	+	+	+	IND	II	-	+	-	CAP	III	-	-	+	IND	IV	+	-	-	CAP
QUADRAT				PF UNIT																						
I	+	+	+	IND																						
II	-	+	-	CAP																						
III	-	-	+	IND																						
IV	+	-	-	CAP																						
Displacement Power Factor (PF)	<p>Same as True PF, But Only With Fundamental Components:</p> $true\ PF = \left \frac{P_{h1}}{S_{h1}} \right , \text{ if } Q > 0 \text{ than CAP; if } Q < 0 \text{ than IND}$																									

SEE ALSO

- [About PQ Monitoring](#)
- [Voltage & Current](#)
- [Averaging](#)
- [Temperature](#)
- [Phasors](#)
- [Waveforms](#)
- [Voltage Flickering](#)
- [Pinst Waveforms](#)
- [Min/Max Flickering](#)
- [V&I Harmonics](#)
- [P&Q Harmonics](#)
- [Spectrum](#)
- [Harmonics Table](#)
- [V/I Min/Max Harmonics](#)
- [P/Q Min/Max Harmonics](#)

Temperature

Ambient temperature is an important parameter for both the immediate external environment and within your Portable BLACKBOX Unit. Temperature extremes do affect measuring accuracy. Therefore, monitoring the internal temperature of the instrument is important when monitoring all measured electrical parameters to ensure that the values can be assumed to be of maximum accuracy. A rise in power supply temperature could be a sign of incorrect probe connections or some other malfunction.

open the temperature window:

- [Access your Portable BLACKBOX Unit](#) via the Web Interface → select **Monitoring** → **Temperature:**

MONITORING	ENERGY	POWER QUALITY
Summary	V & I harmonics	
Voltage & Current	P & Q harmonics	
Average	Spectrum	
Power	Harmonics Table	
Temperature	V/I Min/Max Harmonics	
Phasors	P/Q Min/Max Harmonics	
Waveforms		
Voltage Flickering		
Pinst Waveform		
Min/Max Flickering		

- The Temperature Window will now open:

RO ■ MONITORING » TEMPERATURE			
Reset All Min/Max			
Internal Temperature			
Internal _{avg}	Internal _{min}	Internal _{max}	
45.95 °C	43.99 °C	47.98 °C	
External Temperature			
External _{avg}	External _{min}	External _{max}	
No PT100	No PT100	No PT100	
PSU Temperature			
PSU _{avg}	PSU _{min}	PSU _{max}	
52.19 °C	48.50 °C	57.16 °C	

table - temperature Options:

The table outlines the sections' Parameters including Definition:

Parameter	Definition
Internal Temperature	The average, minimum, and maximum internal temperature of the DSP Module
External Temperature	Utilizing a PT100 Thermometer , average, minimum, and maximum outside temperatures are monitored. The temperatures measured every network cycle and averaged over 10 cycles. The data is stored in the PQZIP files every 10 minutes.
PSU Temperature	The average minimum and maximum temperature of the General Power Supply of your Portable BLACKBOX Unit
Reset All Min/Max	Reset all Min/Max measurements of your G4K Unit

SEE ALSO

- [About PQ Monitoring](#)
- [Voltage & Current](#)
- [Averaging](#)
- [Power](#)
- [Phasors](#)
- [Waveforms](#)
- [Voltage Flickering](#)
- [Pinst Waveforms](#)
- [Min/Max Flickering](#)
- [V&I Harmonics](#)
- [P&Q Harmonics](#)
- [Spectrum](#)
- [Harmonics Table](#)
- [V/I Min/Max Harmonics](#)
- [P/Q Min/Max Harmonics](#)

Phasors

A Phasor is a vector representation of the Voltages & Currents in the system. The Phasor Window of the BLACKBOX Web Interface represents both Wye and Delta Voltage Configurations in a Phasor format. Therefore, the Phasors are a vector representation of the First Harmonic.

NOTE NOTE NOTE

- In order to display the Phasor graph, ensure that you install the ActiveX plug-in from Gigasoft (downloadable either from [Elspec's Website's Support Section](#) or alternatively can be installed directly from your [BLACKBOX CD](#)). You will receive the following error message if the program is not installed:

**Charting plugin initialization failed!
Browser security prevents automatic
installation of ActiveX control**

- For Internet Explorer 8/9 Users:** Once you have installed Gigasoft, ensure that the Internet Explorer is running in **Compatibility View**:



open the phasors window:

- [Access your Portable BLACKBOX Unit](#) via the Web Interface ➔ select **Monitoring**
➔ **Phasors:**

MONITORING	ENERGY	POWER QUALITY
Summary		V & I harmonics
Voltage & Current		P & Q harmonics
Average		Spectrum
Power		Harmonics Table
Temperature		V/I Min/Max Harmonics
Phasors		P/Q Min/Max Harmonics
Waveforms		
Voltage Flickering		
Pinst Waveform		
Min/Max Flickering		

- The Phasor Window will now open:

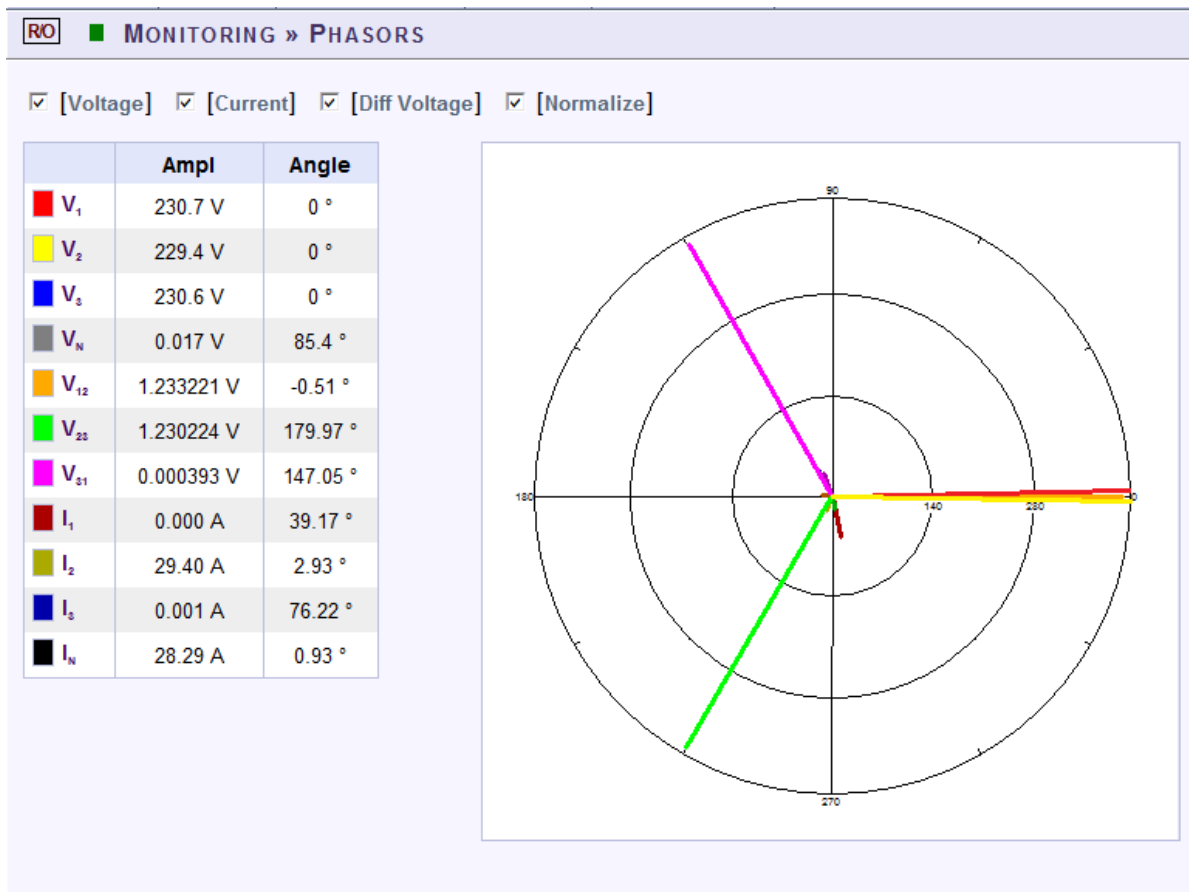

table - phasors options:

The table outlines the sections' Parameter options (for your selection) including their Definition:

Parameter	Definition
-----------	------------

Voltage	Displays Voltage Phase to Neutral Phasor (only present with WYE 4 Wire configuration)
Current	Displays Phase Current
Diff Voltage	Displays the Phase to Neutral Voltages Phasor
Diff Current	Displays the Phase to Phase Current (only present with Delta 3 Wire configuration)
Normalize	Displays the all vector as part of the largest vector
Ampl	The Amplitude of each Phasor
Angle	V1 /V12 is at 0°, all other vectors are in relation to V1 /V12

chart options:

- Right-click on the chart to access various options & capabilities for the chart:

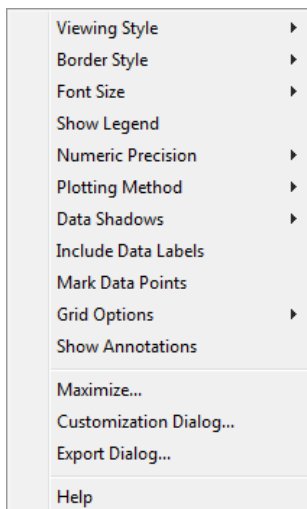

You may use the following chart options & capabilities:

- **Viewing Style:** Different styling options Color / Monochrome (B&W) with/without Symbols / Bitmap etc. By selecting the option you can view on screen the different styles available to you
- **Border Style:** No Border, Thin Line, Shadow / Inset
- **Font Size:** Large / Medium / Small
- **Show Legend:** Display / Not display Legend
- **Plotting Method:** From Line / Point / Point & Line
- **Data Shadows:** Off / Shadow / 3D
- **Include Data Labels:** Include / Exclude Numeric Data Labels
- **Mark Data Points:** Mark/Unmark Data Points

- **Grid Options:** Extend Radius Tick Marks, Both Degrees & Radius, Degrees, Radius, Hid Grid Lines, Thin Grid Lines, Thick Grid Lines, Dotted Grid Lines, Dashed Grid Lines & One Pixel Grid Lines
- **Maximize:** Min / Max the Phasor Graph Only
- **Customization Dialog:** Various General Graph Customization Options (all options):

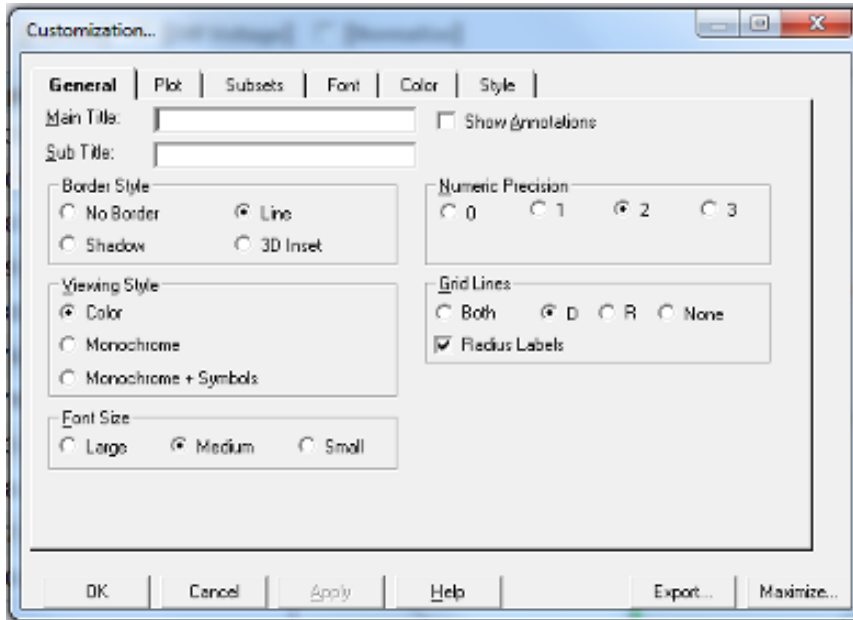

- **Export Dialog - Various Export Options:**

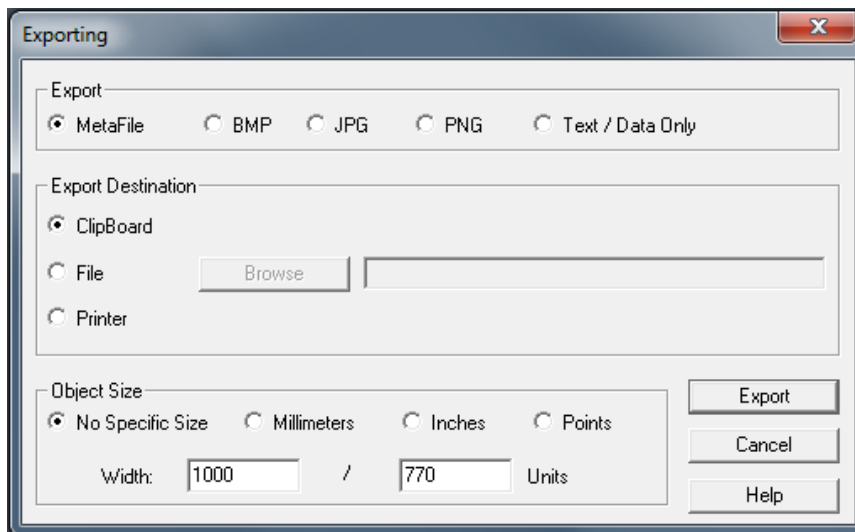

SEE ALSO

- [About PQ Monitoring](#)
- [Voltage & Current](#)
- [Averaging](#)
- [Power](#)
- [Temperature](#)
- [Waveforms](#)
- [Voltage Flickering](#)
- [Pinst Waveforms](#)
- [Min/Max Flickering](#)
 - [V&I Harmonics](#)
- [P&Q Harmonics](#)
- [Spectrum](#)
- [Harmonics Table](#)
- [V/I Min/Max Harmonics](#)
- [P/Q Min/Max Harmonics](#)

Waveforms

The Waveform page displays the actual Voltage & Current waveforms monitored by your Portable BLACKBOX Unit.

NOTE NOTE NOTE

- In order to display the Phasor graph, ensure that you install the ActiveX plug-in from Gigasoft (downloadable either from [Elspec's Website's Support Section](#) or alternatively can be installed directly from your [BLACKBOX CD](#)). You will receive the following error message if the program is not installed:

**Charting plugin initialization failed!
Browser security prevents automatic
installation of ActiveX control**

- **For Internet Explorer 8/9 Users:** Once you have installed Gigasoft, ensure that the Internet Explorer is running in **Compatibility View**:



OPEN the waveforms window:

- [Access your Portable BLACKBOX Unit](#) via the Web Interface ➔ select **Monitoring**
➔ **Waveforms**:

MONITORING	ENERGY	POWER QUALITY
Summary		V & I harmonics
Voltage & Current		P & Q harmonics
Average		Spectrum
Power		Harmonics Table
Temperature		V/I Min/Max Harmonics
Phasors		P/Q Min/Max Harmonics
Waveforms		
Voltage Flickering		
Pinst Waveform		
Min/Max Flickering		

- The Waveforms Window will now open:

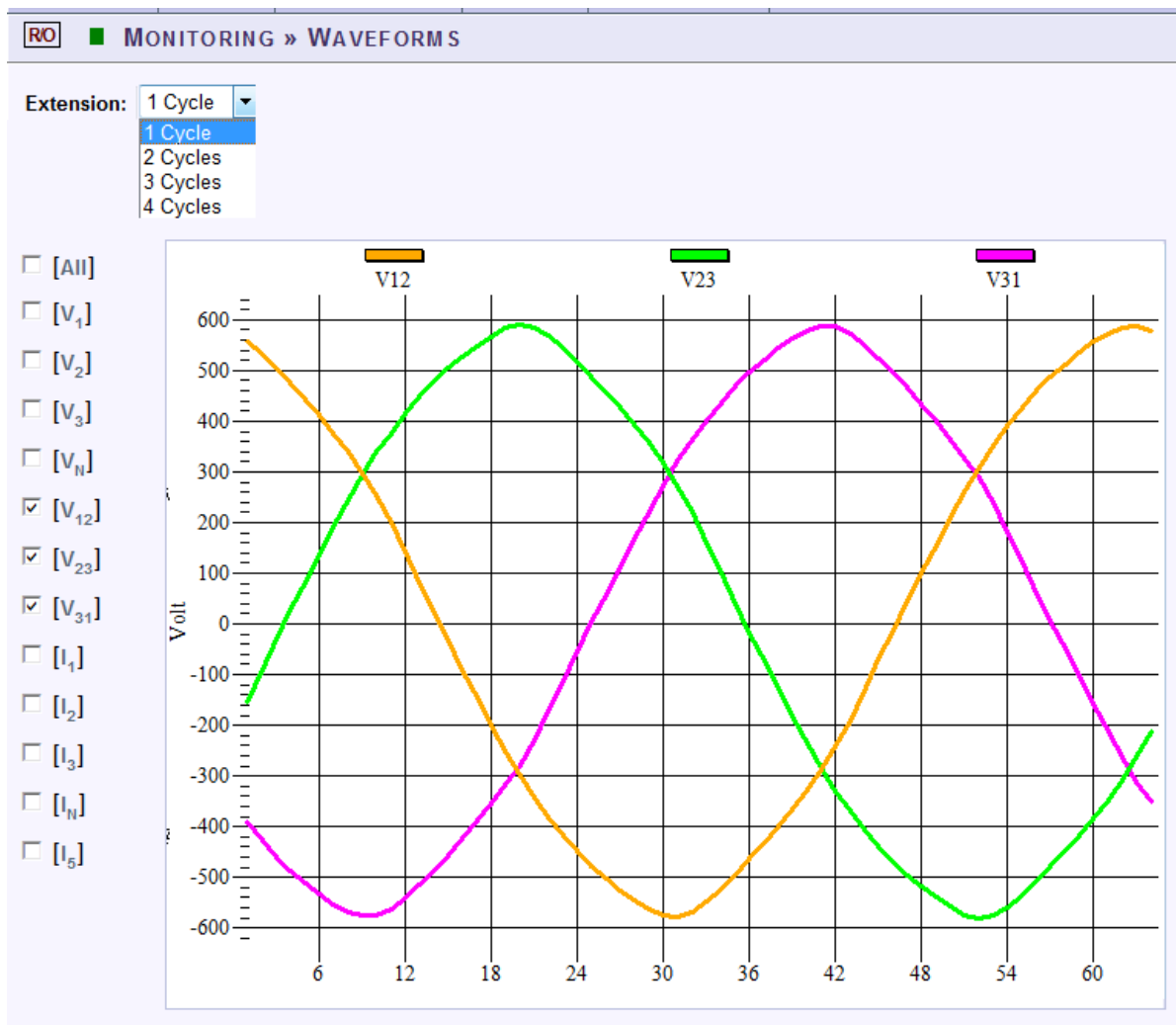

table - waveform options:

The table outlines the sections' Parameter options (for your selection) including their Definition:

Parameter	Definition
Cycle	Cycle Selection (1-4 Cycles)
All	Checking the "All graphs" box will automatically select all the boxes below
Voltage & Current	Depending on your power configuration, you can view all combinations of phase to phase and phase to line voltage and current combinations by making selections in the appropriate check boxes

chart options:

- By right-clicking on the chart you have various chart options & capabilities available to you:

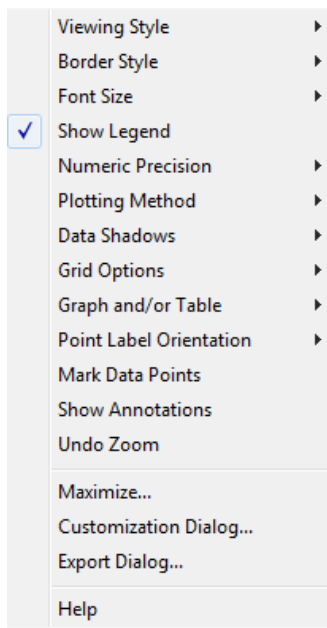

- **Viewing Style:** Different styling options Color / Monochrome (B&W) with/without Symbols / Bitmap etc. By selecting the option you can view on screen the different styles available to you
- **Border Style:** No Border, Thin Line, Shadow / Inset
- **Font Size:** Large / Medium / Small
- **Display / Not display Legend**
- **Numeric Precision:** No up to 3 Decimals
- **Plotting Method:** From Line / Bar / Point / Area / Spline / Combinations
- **Data Shadows:** Off / Shadow / 3D
- **Grid Options:** Various grid options ranging from dots / lines / different axis etc.
- **Graph & Table:** Display either the graph / table / both:

V1	-0.610	0.316	0.487	-0.659	-0.220	0.512	-0.413	-1.240	-0.145	0.245
V2	-0.514	0.270	0.245	-0.586	-0.219	0.391	-0.075	-0.516	0.097	0.195
V3	-0.927	0.439	0.463	-0.903	-0.367	0.756	-0.243	-0.876	0.465	0.318
VN	0.122	-0.049	-0.391	-0.293	-0.513	-0.318	-0.293	-0.220	0.024	0.073
V12	0.244	0.049	0.098	-0.047	-0.338	0.001	-0.000	-0.266	-0.243	0.340
V23	0.317	0.365	-0.293	-0.050	0.509	-0.123	-0.146	0.388	0.219	-0.365
V31	-0.561	-0.415	0.195	0.097	-0.172	0.122	0.146	-0.123	0.024	0.025
I1	3.906	0.244	-1.465	0.488	-0.244	0.488	1.221	0.977	-0.977	0.488
I2	3.418		-1.709	0.244	-0.488	0.977	0.732	0.732	-1.465	0.244
I3	3.174	0.488	-1.221	0.488		0.488	0.244	0.488	-1.221	-1.221
IN	0.732	-0.244	-1.953	-1.465	-2.197	-0.488		-0.977	-1.465	-0.488

- **Point Label Orientation:** Auto / Vertical / Horizontal / Slanted
- **Mark Data Points:** Displays data points on graph
- **Show Annotations:** Displays annotations data descriptions
- **Zoom / Undo Zoom - Zoom in /out on your graph:**
 - From the main Waveform window, select an area to zoom in. Left-click and drag the mouse to define the area:

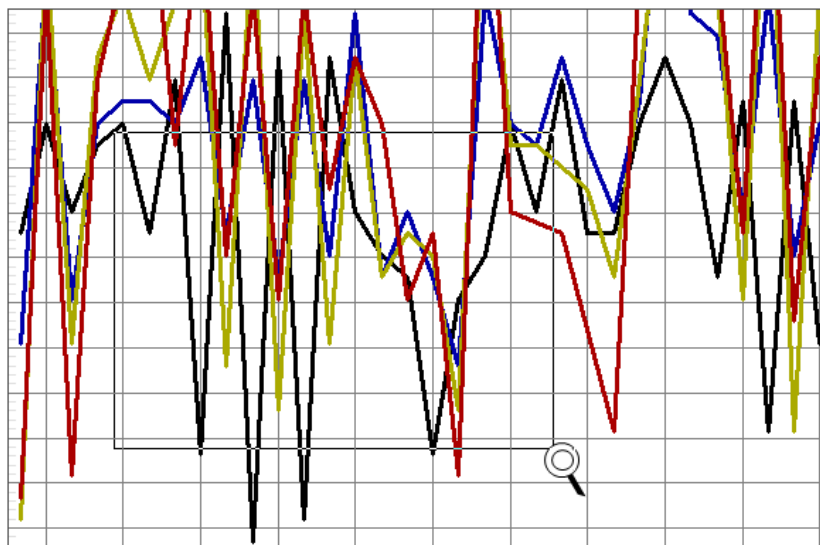

- The enlarged area will now appear in the window
- Zoom out by right/click ➡ & select **Zoom out**
- **Maximize:** Maximize / Minimize graph

- **Customization Dialog - Various General Graph Customization Options** (all options apart from zooming above):

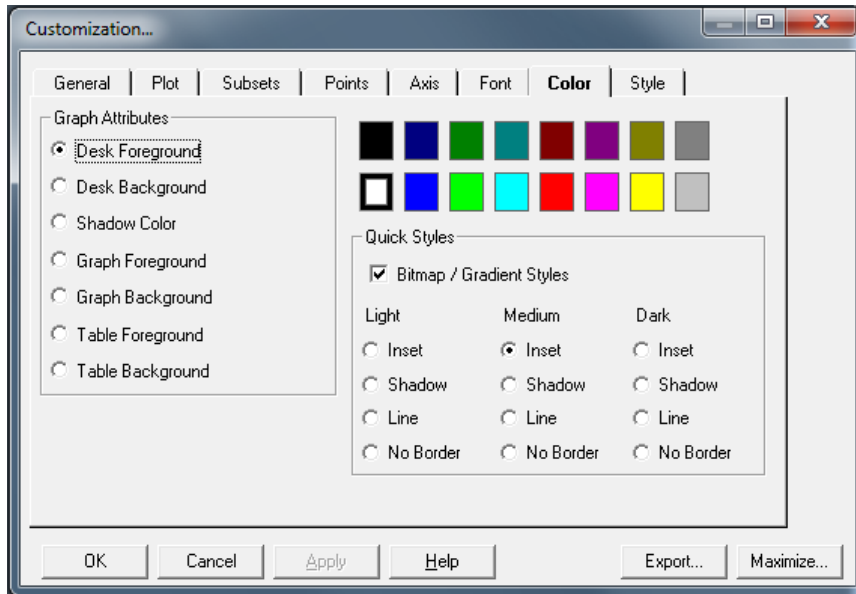

- **Export Dialog - Various Export Options:**

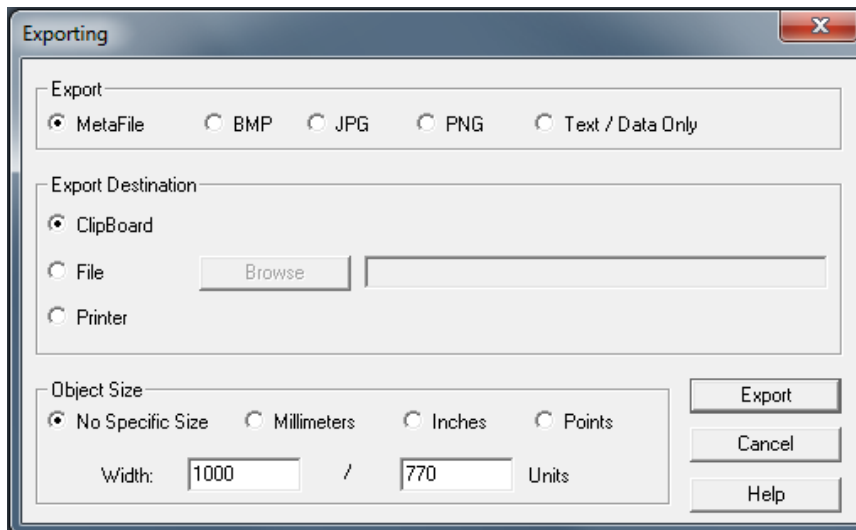

SEE ALSO

- [About PQ Monitoring](#)
- [Voltage & Current](#)
- [Averaging](#)
- [Power](#)
- [Temperature](#)
- [Phasors](#)
- [Voltage Flickering](#)
- [Pinst Waveforms](#)
- [Min/Max Flickering](#)
- [V&I Harmonics](#)
- [P&Q Harmonics](#)
- [Spectrum](#)
- [Harmonics Table](#)
- [V/I Min/Max Harmonics](#)
- [P/Q Min/Max Harmonics](#)

Voltage Flickering

Displays the short & long term Voltage Flickering to a very close approximation of the EN50160 values.

OPEN THE VOLTAGE FLICKERING WINDOW:

- Access your **Portable BLACKBOX Unit** via the Web Interface → select **Monitoring** → **Voltage Flickering**:

MONITORING	ENERGY	POWER QUALITY
Summary	V & I harmonics	
Voltage & Current	P & Q harmonics	
Average	Spectrum	
Power	Harmonics Table	
Temperature	V/I Min/Max Harmonics	
Phasors	P/Q Min/Max Harmonics	
Waveforms		
Voltage Flickering		
Pinst Waveform		
Min/Max Flickering		

- The **Voltage Flickering Window** will now open:

MONITORING » VOLTAGE FLICKERING								
Reset Flickering								
Voltage Flickering								
	PST INST	PSST 10 Sec.	PST 10 Min.	SPLT 1 Hour	PLT 2 Hour	LPLT 10 Hour	LPLT 1 Day	LPLT 7 Day
V ₁	10.261	9.9621	96.653	10.472	N/A	N/A	N/A	N/A
V ₂	3.0913	2.8673	95.901	3.2235	N/A	N/A	N/A	N/A
V ₃	9.8416	9.7259	95.952	10.159	N/A	N/A	N/A	N/A
V ₁₂	1172.1	1561.5	152.00	182.70	N/A	N/A	N/A	N/A
V ₂₃	1253.7	1611.5	150.77	182.70	N/A	N/A	N/A	N/A
V ₃₁	1155.0	1069.4	182.70	182.70	N/A	N/A	N/A	N/A
		10 Min.			2 Hours			
Timestamp	25/12/2011 16:40:00			DD/MM/YYYY HH:MM:SEC				
Flag	Flagged: V1,V2,V3			Not flagged				

TABLE - VOLTAGE FLICKERING CALCULATIONS & WINDOW OPTIONS:

The table outlines the sections' Parameter options (for your selection) including their Definition:

Parameter	Definition
PST INST	Instantaneous flicker evaluation. Output of Block 5 of the Flickermeter in Accordance with IEC61000-4-15 Edition 2
PSST 10 Sec.	<p>An Elspec measurement designed to get quicker results regarding Flicker evaluation. This measurement reaches a very close approximation of the EN50160 values, but in a fraction of the time.</p> <p>The PSST is calculated the same as PST but averaged over 10 seconds. This Elspec defined value is valuable in that it enables faster assessment of the flicker. Elspec PSST converges to a real value within 3 min from a drastic flicker change, or immediately for periodic steady state flicker</p>
PST	$P_{ST} = \sqrt{0.0314P_{0.1} + 0.0525P_{1s} + 0.0657P_{3s} + 0.28P_{10s} + 0.08P_{50s}}$ <p>Where the Percentiles $P_{0.1}$, P_1, P_3, P_{10} & P_{50} are the Flicker Levels Exceeded for 0.1, 1, 3, 10 & 50% of the Time During The Observation Period. The Suffix "s" in the Formula Indicates that the Smoothed Value Should be Used. The Smoothed Values are Obtained Using the Following Formulas:</p> $P(1s) = (P(.7) + P(1) + P(1.5))/3$ $P(3s) = (P(2.2) + P(3) + P(4))/3$ $P(10s) = (P(6) + P(8) + P(10) + P(13) + P(17))/5$ $P(50s) = (P(30) + P(50) + P(80))/3$
PST 10 Min	<p>Short term flicker evaluation.</p> <p>P_{ST} is a value measured over 10 minutes that characterizes the likelihood that the voltage fluctuations would result in perceptible light flicker. A value of 1.0 is designed to represent that 50% of people would perceive flicker in a 60 watt incandescent bulb.</p>
PLT	$P_{LT} = \sqrt[3]{\frac{\sum_{i=1}^N P_{STi}^3}{N}}$ <p>Where P_{STi} ($i = 1, 2, 3, \dots$) are the Consecutive Readings of the P_{ST}</p>
SPLT 1 Hour	<p>An Elspec measurement designed to get quicker results regarding Flicker evaluation. This measurement reaches a very close approximation of the EN50160 values, but in a fraction of the time.</p> <p>The SPLT is calculated the same as PLT but averaged over 1 hour. This Elspec defined value is valuable in that it enables faster assessment of the flicker</p>

Parameter	Definition
PLT 2 Hour	The Long-Term PLT is Derived From the Short-Term Values Over 12 Short-Term Values of 10 Minutes Each Over a Period of 2 hours
LPLT 10 Hour	An Elspec measurement designed to give better results regarding Flicker evaluation by using a longer averaging time. The LP_{LT} is calculated the same as P_{LT} but averaged over 10 hours to allow a quicker "long term" average
LPLT 7 Day	An Elspec measurement designed to give better results regarding Flicker evaluation by using a longer averaging time. The LP_{LT} is calculated the same as P_{LT} but averaged over 7 days, as per EN50160 parts 4-15
Reset Flickering	Reset all Flickering measurements of your G4K Unit

SEE ALSO:

- [About PQ Monitoring](#)
- [Voltage & Current](#)
- [Averaging](#)
- [Power](#)
- [Temperature](#)
- [Phasors](#)
- [Waveforms](#)
- [Pinst Waveforms](#)
- [Min/Max Flickering](#)
- [V&I Harmonics](#)
- [P&Q Harmonics](#)
- [Spectrum](#)
- [Harmonics Table](#)
- [V/I Min/Max Harmonics](#)
- [P/Q Min/Max Harmonics](#)

Pinst Waveform

Pinst is instantaneous flicker sensation that the G4500/G3500 Portable BLACKBOX calculates for every selected channel.

OPEN PINST WAVEFORM WINDOW:

- [Access your Portable BLACKBOX Unit](#) via the Web Interface ➔ select **Monitoring** ➔ **Pinst Waveforms:**

MONITORING	ENERGY	POWER QUALITY
Summary		V & I harmonics
Voltage & Current		P & Q harmonics
Average		Spectrum
Power		Harmonics Table
Temperature		V/I Min/Max Harmonics
Phasors		P/Q Min/Max Harmonics
Waveforms		
Voltage Flickering		
Pinst Waveform		
Min/Max Flickering		

- The Pinst Waveforms Window will now open:

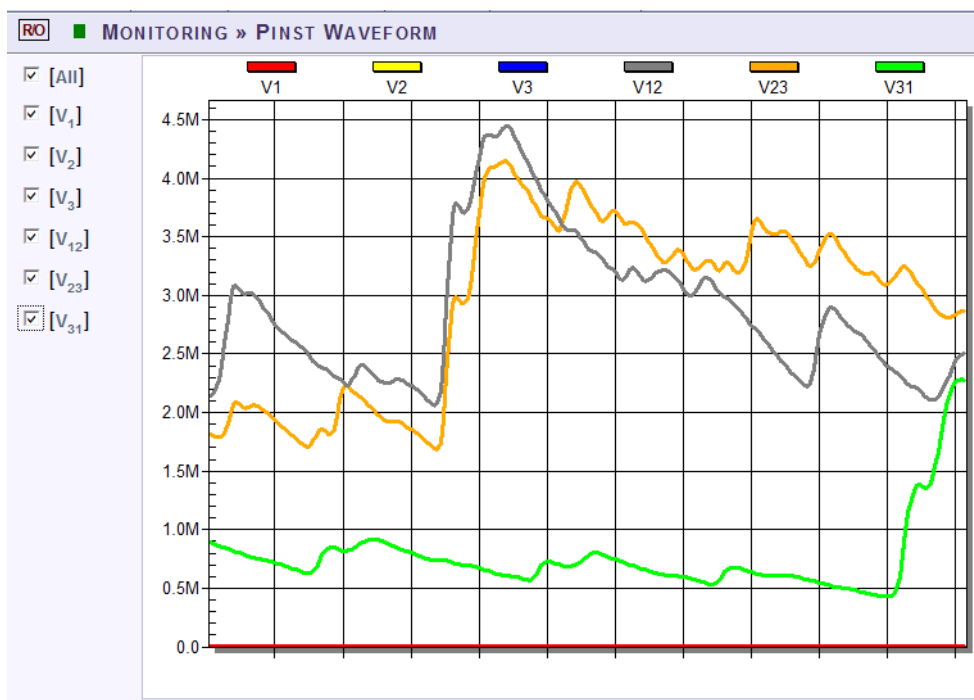

TABLE - PINST WAVEFORM WINDOW OPTIONS:

The table outlines the sections' Parameter options (for your selection) including their Definition:

Parameter	Definition
All	Checking the "All graphs" box will automatically select all the boxes below
Voltage Channels	Select the applicable channel for Flickering Waveform display.

SEE ALSO:

- [About PQ Monitoring](#)
- [Voltage & Current](#)
- [Averaging](#)
- [Power](#)
- [Temperature](#)
- [Phasors](#)
- [Waveforms](#)
- [Voltage Flickering](#)
- [Min/Max Flickering](#)
- [V&I Harmonics](#)
- [P&Q Harmonics](#)
- [Spectrum](#)
- [Harmonics Table](#)
- [V/I Min/Max Harmonics](#)
- [P/Q Min/Max Harmonics](#)

Minimum / Maximum Flickering

Displays the minimum & maximum short & long term Voltage Flickering vales to a very close approximation of the EN50160 values.

OPEN MIN/MAX FLICKERING WINDOW:

- [Access your Portable BLACKBOX Unit](#) via the Web Interface ➔ select **Monitoring**
➔ **Min/Max Flickering:**

MONITORING	ENERGY	POWER QUALITY
Summary	V & I harmonics	
Voltage & Current	P & Q harmonics	
Average	Spectrum	
Power	Harmonics Table	
Temperature	V/I Min/Max Harmonics	
Phasors	P/Q Min/Max Harmonics	
Waveforms		
Voltage Flickering		
Pinst Waveform		
Min/Max Flickering		

- The Min/Max Flickering Window will now open:

MONITORING » MIN/MAX FLICKERING									
Reset All Min/Max									
Min/Max Flickering									
		PSST 2 Sec.	PSST 10 Sec.	PST 10 Min.	SPLT 1 Hour	PLT 2 Hour	LPLT 10 Hour	LPLT 1 Day	LPLT 7 Day
V ₁	Min.	N/A	N/A	N/A	N/A	N/A	N/A	N/A	N/A
	Max.	***	***	96.653	10.472	N/A	N/A	N/A	N/A
V ₂	Min.	N/A	N/A	N/A	N/A	N/A	N/A	N/A	N/A
	Max.	***	***	95.901	3.2235	N/A	N/A	N/A	N/A
V ₃	Min.	N/A	N/A	N/A	N/A	N/A	N/A	N/A	N/A
	Max.	***	***	95.952	10.159	N/A	N/A	N/A	N/A
V ₁₂	Min.	N/A	N/A	N/A	N/A	N/A	N/A	N/A	N/A
	Max.	32223	15293	182.70	182.70	N/A	N/A	N/A	N/A
V ₂₃	Min.	N/A	N/A	N/A	N/A	N/A	N/A	N/A	N/A
	Max.	31954	15188	182.70	182.70	N/A	N/A	N/A	N/A
V ₃₁	Min.	N/A	N/A	N/A	N/A	N/A	N/A	N/A	N/A
	Max.	2537.0	1680.0	182.70	182.70	N/A	N/A	N/A	N/A

TABLE - MIN/MAX FLICKERING CALCULATION METHOD:

The table outlines the sections' Parameter options (for your selection) including their Definition:

Parameter	Definition
PST INST	Instantaneous flicker evaluation. Output of Block 5 of the Flickermeter in Accordance with IEC61000-4-15 Edition 2
PSST 10 Sec.	<p>An Elspec measurement designed to get quicker results regarding Flicker evaluation. This measurement reaches a very close approximation of the EN50160 values, but in a fraction of the time.</p> <p>The PSST is calculated the same as PST but averaged over 10 seconds. This Elspec defined value is valuable in that it enables faster assessment of the flicker. Elspec PSST converges to a real value within 3 min from a drastic flicker change, or immediately for periodic steady state flicker</p>
PST	$P_{ST} = \sqrt{0.0314P_{0.1} + 0.0525P_{1s} + 0.0657P_{3s} + 0.28P_{10s} + 0.08P_{50s}}$ <p>Where the Percentiles $P_{0.1}$, P_1, P_3, P_{10} & P_{50} are the Flicker Levels Exceeded for 0.1, 1, 3, 10 & 50% of the Time During The Observation Period. The Suffix “s” in the Formula Indicates that the Smoothed Value Should be Used. The Smoothed Values are Obtained Using the Following Formulas:</p> <p>$P(1s) = (P(.7) + P(1) + P(1.5))/3$</p> <p>$P(3s) = (P(2.2) + P(3) + P(4))/3$</p> <p>$P(10s) = (P(6) + P(8) + P(10) + P(13) + P(17))/5$</p> <p>$P(50s) = (P(30) + P(50) + P(80))/3$</p>
PST 10 Min	<p>Short term flicker evaluation.</p> <p>P_{ST} is a value measured over 10 minutes that characterizes the likelihood that the voltage fluctuations would result in perceptible light flicker. A value of 1.0 is designed to represent that 50% of people would perceive flicker in a 60 watt incandescent bulb.</p>
PLT	$P_{LT} = \sqrt[3]{\frac{\sum_{i=1}^N P_{STi}^3}{N}}$ <p>Where P_{STi} ($i = 1, 2, 3, \dots$) are the Consecutive Readings of the P_{ST}</p> <p>Where P_{sti} ($i = 1, 2, 3, \dots$) are Consecutive Readings of the Short-Term Severity P_{ST}</p>

Parameter	Definition
SPLT 1 Hour	<p>An Elspec measurement designed to get quicker results regarding Flicker evaluation. This measurement reaches a very close approximation of the EN50160 values, but in a fraction of the time.</p> <p>The SPLT is calculated the same as PLT but averaged over 1 hour. This Elspec defined value is valuable in that it enables faster assessment of the flicker</p>
PLT 2 Hour	The Long-Term PLT is Derived From the Short-Term Values Over 12 Short-Term Values of 10 Minutes Each Over a Period of 2 hours
LPLT 10 Hour	<p>An Elspec measurement designed to give better results regarding Flicker evaluation by using a longer averaging time. The LP_{LT} is calculated the same as P_{LT} but averaged over 10 hours to allow a quicker "long term" average</p>
LPLT 7 Day	<p>An Elspec measurement designed to give better results regarding Flicker evaluation by using a longer averaging time.</p> <p>The LP_{LT} is calculated the same as P_{LT} but averaged over 7 days, as per EN50160 parts 4-15</p>
Reset Flickering	Reset all Flickering measurements of your G4K Unit

SEE ALSO:

- [About PQ Monitoring](#)
- [Voltage & Current](#)
- [Averaging](#)
- [Power](#)
- [Temperature](#)
- [Phasors](#)
- [Waveforms](#)
- [Voltage Flickering](#)
- [Pinst Waveforms](#)
- [V&I Harmonics](#)
- [P&Q Harmonics](#)
- [Spectrum](#)
- [Harmonics Table](#)
- [V/I Min/Max Harmonics](#)
- [P/Q Min/Max Harmonics](#)

Voltage & Current Harmonics

This window opens the Spectrum of Voltage & Current Harmonics measured by your Portable BLACKBOX Unit. The graph in the web interface displays up to 50 Harmonics. In order to view the full Harmonic spectrum, kindly access PQSCADA.

OPEN V&I HARMONICS WINDOW:

- Access your [Portable BLACKBOX Unit](#) via the Web Interface → select **Monitoring** → **V&I Harmonics**:

MONITORING	ENERGY	POWER QUALITY
Summary		V & I harmonics
Voltage & Current		P & Q harmonics
Average		Spectrum
Power		Harmonics Table
Temperature		V/I Min/Max Harmonics
Phasors		P/Q Min/Max Harmonics
Waveforms		
Voltage Flickering		
Pinst Waveform		
Min/Max Flickering		

- The V&I Harmonics Window will now open:

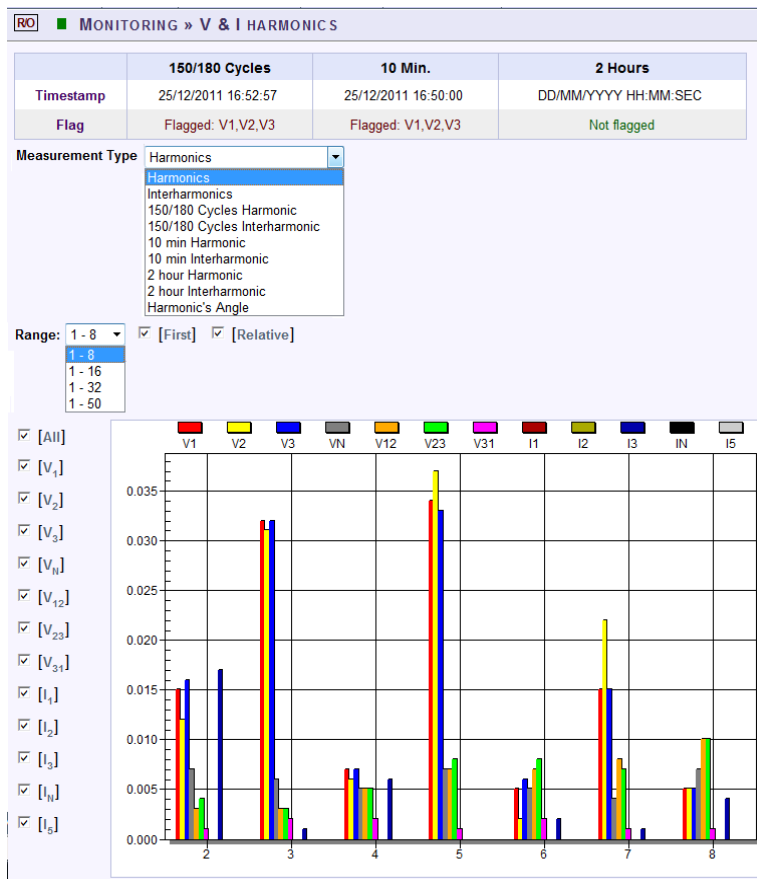

TABLE - V&I HARMONICS CALCULATION METHOD & WINDOW OPTIONS:

The table outlines the sections' Parameter options (for your selection) including their Definition:

Parameter	Definition
Timestamp	Indicates the timestamps of the last averaging intervals
Flag	Indicates whether or not the last interval is valid according to the set standard
MEASUREMENT TYPE	
Harmonics	Real time (10/12 cycles) calculation of sub group harmonics, in accordance with IEC61000-4-7: $G_{sg,n}^2 = \sum_{i=1}^1 C_{k+i}^2$
Interharmonics	Real time (10/12 cycles) calculation of inter sub group harmonics, in accordance with IEC61000-4-7
150/180 Cycles Harmonic	150/180 Cycle averaging of the sub group harmonics
150/180 Cycles Interharmonic	150/180 Cycle averaging of the inter sub group harmonics
10 Min Harmonic	10 Minutes averaging of the sub group harmonics
10 Min Interharmonic	10 Minutes averaging of the inter sub group harmonics
2 Hour Harmonic	2 Hours averaging of the 10 minutes averaging of the sub group harmonics
2 Hour Interharmonic	2 Hours averaging of the 10 minutes averaging of the inter sub group harmonics
Harmonic's Angle	The angle of each harmonic based on the real time value
RANGE	
1-8	Select the number of harmonics to be displayed 1-8
1-16	Select the number of harmonics to be displayed 1-16
1-32	Select the number of harmonics to be displayed 1-32

1-50	Select the number of harmonics to be displayed 1-50
OPTIONS	
First	Check/Uncheck the checkbox in order to display/not display the first harmonic
Relative	Check/Uncheck the checkbox in order to display/not display the harmonics relative to the first harmonic (Whereas the first harmonic is 100, and the other harmonic values as part of the harmonic 100)
All	Checking the "All" will display all the channels
Voltage & Current	Select the applicable Voltage / Current channel to be displayed

CHART OPTIONS:

- By right-clicking on the chart you have various chart options & capabilities available to you:

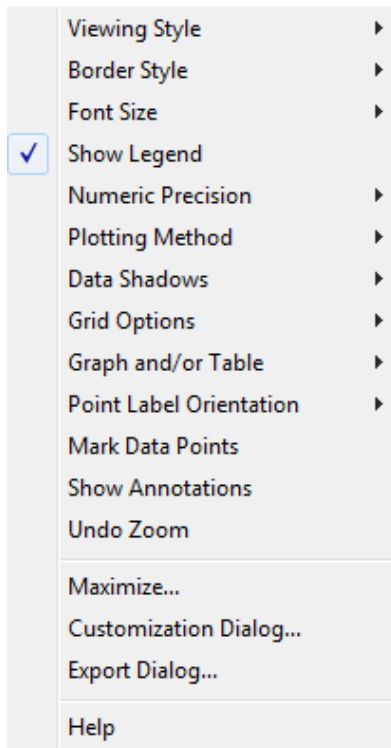

- Viewing Style:** Different styling options Color / Monochrome (B&W) with/without Symbols / Bitmap etc. By selecting the option you can view on screen the different styles available to you
- Border Style:** No Border, Thin Line, Shadow / Inset
- Font Size:** Large / Medium / Small
- Display / Not display Legend**
- Numeric Precision:** No up to 3 Decimals
- Plotting Method:** From Line / Bar / Point / Area / Spline / Combinations
- Data Shadows:** Off / Shadow / 3D

- **Grid Options:** Various grid options ranging from dots / lines / different axis etc.
- **Graph & Table:** Display either the graph / table / both:

	4	5	6
V1	0.016	0.003	0.005
V2	0.013	0.003	0.003
V3	0.017	0.003	0.005
VN	0.002	0.003	0.003
V12	0.005	0.003	0.003
V23	0.006	0.002	0.003
V31	0.003	0.003	0.002

- **Point Label Orientation:** Auto / Vertical / Horizontal / Slanted
- **Mark Data Points:** Displays data points on graph
- **Show Annotations:** Displays annotations data descriptions
- **Zoom / Undo Zoom - Zoom in /out on your graph:**
 - From the main Waveform window, select an area to zoom in. Left-click and drag the mouse to define the area:

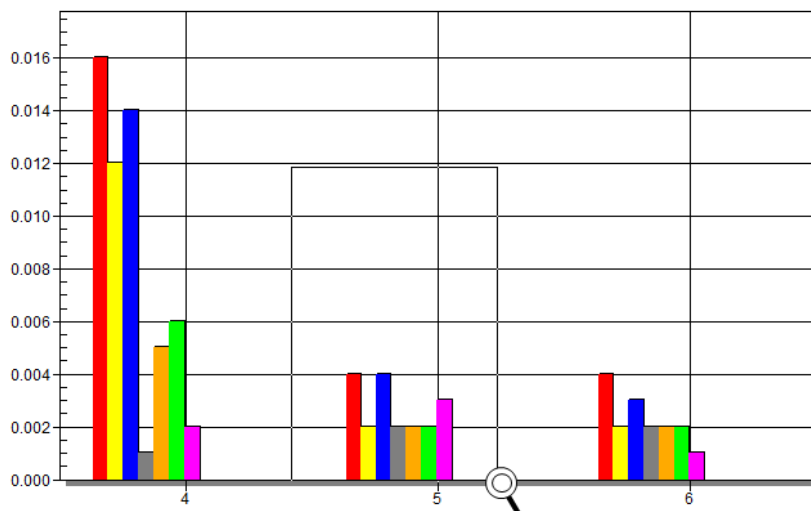

- The enlarged area will now appear in the window
 - Zoom out by right/click ➡ & select **Zoom out**
- **Maximize:** Maximize / Minimize graph
- **Customization Dialog - Various General Graph Customization Options** (all options apart from zooming above):

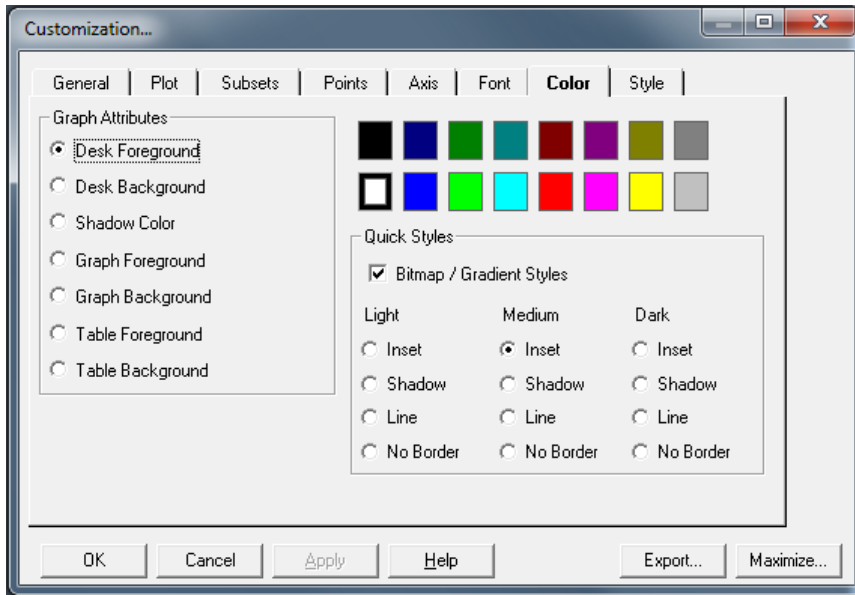

▪ **Export Dialog - Various Export Options:**

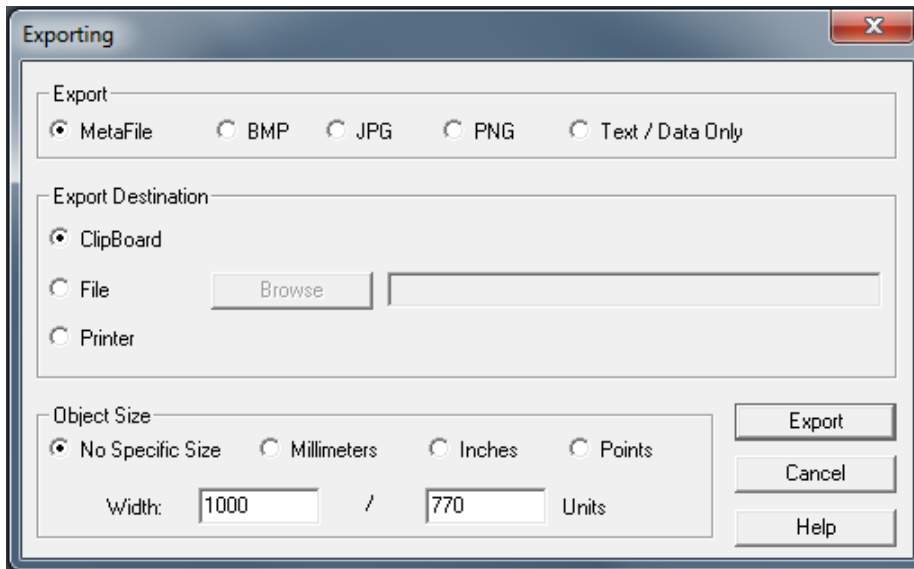

SEE ALSO

- [About PQ Monitoring](#)
- [Voltage & Current](#)
- [Averaging](#)
- [Power](#)
- [Temperature](#)
- [Phasors](#)
- [Waveforms](#)
- [Voltage Flickering](#)
- [Pinst Waveforms](#)
- [Min/Max Flickering](#)
- [P&Q Harmonics](#)
- [Spectrum](#)
- [Harmonics Table](#)
- [V/I Min/Max Harmonics](#)
- [P/Q Min/Max Harmonics](#)

PQ Harmonics

This window opens the Active & Reactive Harmonic Powers measured by your Portable BLACKBOX Unit.

OPEN THE P&Q HARMONICS WINDOW:

- [Access your Portable BLACKBOX Unit](#) via the Web Interface ➔ select **Monitoring**
➔ **P&Q Harmonics:**

MONITORING	ENERGY	POWER QUALITY
Summary		V & I harmonics
Voltage & Current		P & Q harmonics
Average		Spectrum
Power		Harmonics Table
Temperature		V/I Min/Max Harmonics
Phasors		P/Q Min/Max Harmonics
Waveforms		
Voltage Flickering		
Pinst Waveform		
Min/Max Flickering		

- The **P&Q Harmonics Window** will now open:

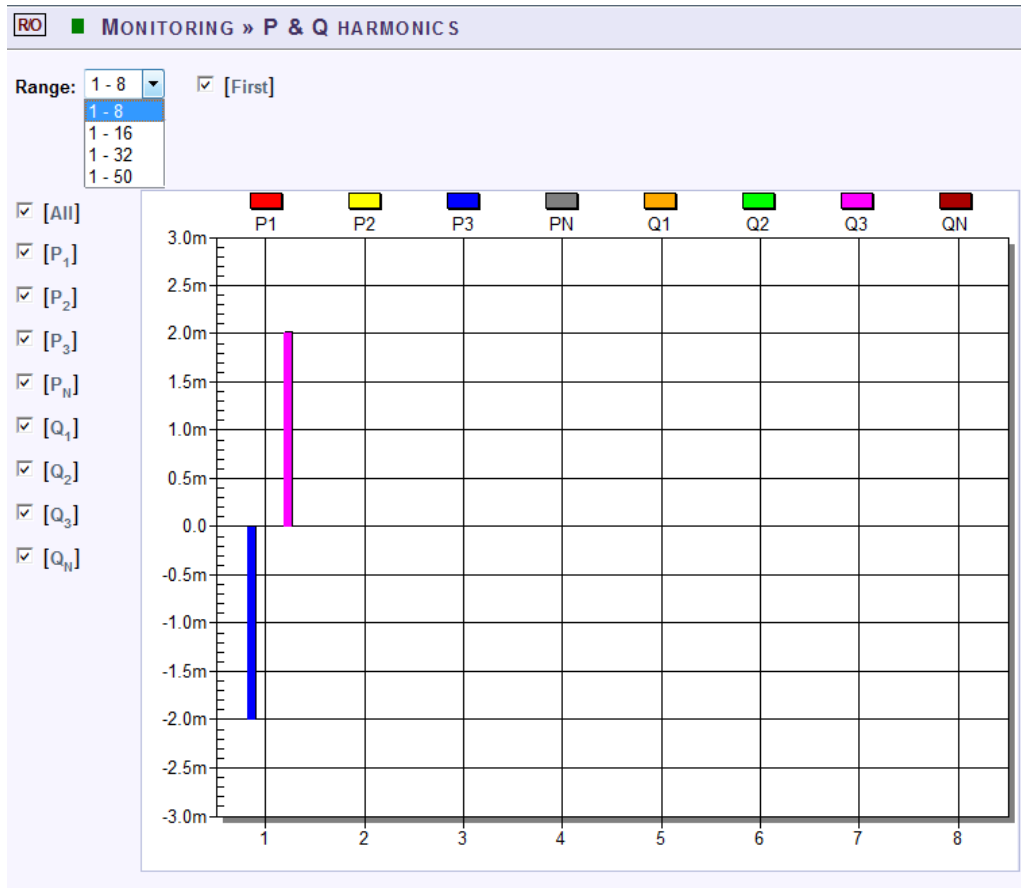

TABLE - P&Q HARMONICS RANGE & WINDOW OPTIONS:

The table outlines the sections' Parameter options (for your selection) including their Definition:

Parameter	Definition
RANGE	
1-8	Select the number of harmonics to be displayed 1-8
1-16	Select the number of harmonics to be displayed 1-16
1-32	Select the number of harmonics to be displayed 1-32
1-50	Select the number of harmonics to be displayed 1-50
OPTIONS	
First	Select either Yes/No in order to display or not display the first harmonic
All	Checking the "All" will display all the channels
P1	Checking the "P1" box will display the Active Power (P) of the first line
P2	Checking the "P2" box will display the Active Power (P) of the second line

P3	Checking the "P3" box will display the Active Power (P) of the third line
Q1	Checking the "Q1" box will display the Reactive Power (Q) of the first line
Q2	Checking the "Q2" box will display the Reactive Power (Q) of the second line
Q3	Checking the "Q3" box will display the Reactive Power (Q) of the third line

CHART OPTIONS:

- By right-clicking on the chart you have various chart options & capabilities available to you:

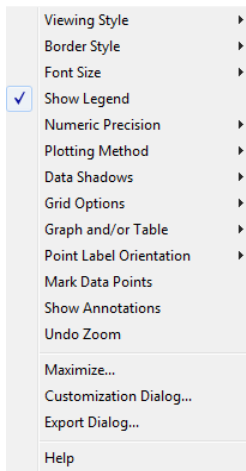

- Viewing Style:** Different styling options Color / Monochrome (B&W) with/without Symbols / Bitmap etc. By selecting the option you can view on screen the different styles available to you
- Border Style:** No Border, Thin Line, Shadow / Inset
- Font Size:** Large / Medium / Small
- Display / Not display Legend**
- Numeric Precision:** No up to 3 Decimals
- Plotting Method:** From Line / Bar / Point / Area / Spline / Combinations
- Data Shadows:** Off / Shadow / 3D
- Grid Options:** Various grid options ranging from dots / lines / different axis etc.
- Graph & Table:** Display either the graph / table / both:

Q1	-0.610	0.316	0.487	-0.659	-0.220	0.512	-0.413	-1.240	-0.145	0.245
Q2	-0.514	0.270	0.245	-0.586	-0.219	0.391	-0.075	-0.516	0.097	0.195
Q3	-0.927	0.439	0.463	-0.903	-0.367	0.756	-0.243	-0.876	0.465	0.318
Q.N.										

- Point Label Orientation:** Auto / Vertical / Horizontal / Slanted
- Mark Data Points:** Displays data points on graph
- Show Annotations:** Displays annotations data descriptions
- Zoom / Undo Zoom - Zoom in /out on your graph:**
 - From the main Waveform window, select an area to zoom in. Left-click and drag the mouse to define the area:

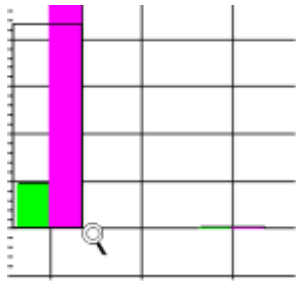

- The enlarged area will now appear in the window
- Zoom out by right/click ➔ & select **Zoom out**
- **Maximize:** Maximize / Minimize graph
- **Customization Dialog - Various General Graph Customization Options** (all options apart from zooming above):

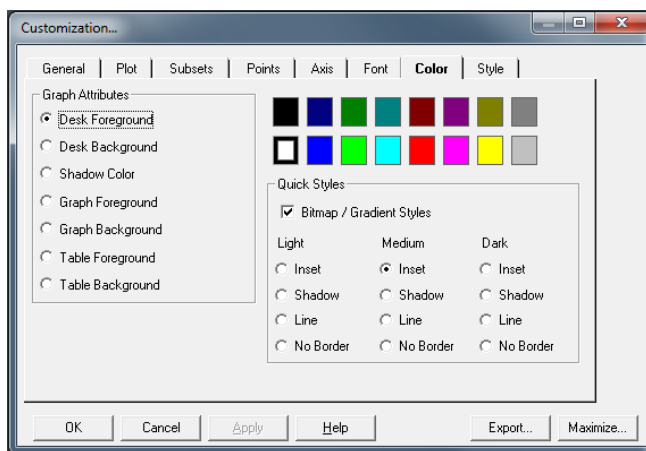

- **Export Dialog - Various Export Options:**

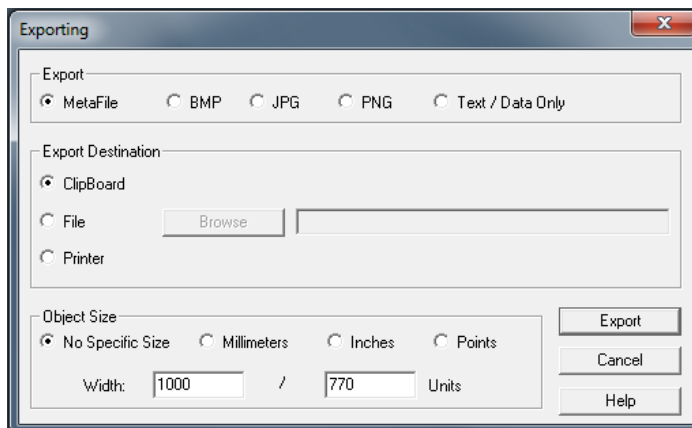

SEE ALSO

- [About PQ Monitoring](#)
- [Voltage & Current](#)
- [Averaging](#)
- [Power](#)
- [Temperature](#)
- [Phasors](#)
- [Waveforms](#)
- [Voltage Flickering](#)
- [Pinst Waveforms](#)
- [Min/Max Flickering](#)
- [V&I Harmonics](#)
- [Spectrum](#)
- [Harmonics Table](#)
- [V/I Min/Max Harmonics](#)
- [P/Q Min/Max Harmonics](#)
- [P&Q Harmonics](#)

Spectrum

This window opens the Voltage & Current Sub & Inter-Harmonics measured by your Portable Power Quality Analyzer.

OPEN THE SPECTRUM WINDOW:

- [Access your Portable BLACKBOX Unit](#) via the Web Interface → select **Monitoring** → **Spectrum:**

MONITORING	ENERGY	POWER QUALITY
Summary		V & I harmonics
Voltage & Current		P & Q harmonics
Average		<u>Spectrum</u>
Power		Harmonics Table
Temperature		V/I Min/Max Harmonics
Phasors		P/Q Min/Max Harmonics
Waveforms		
Voltage Flickering		
Pinst Waveform		
Min/Max Flickering		

- The **Spectrum Window** will now open:

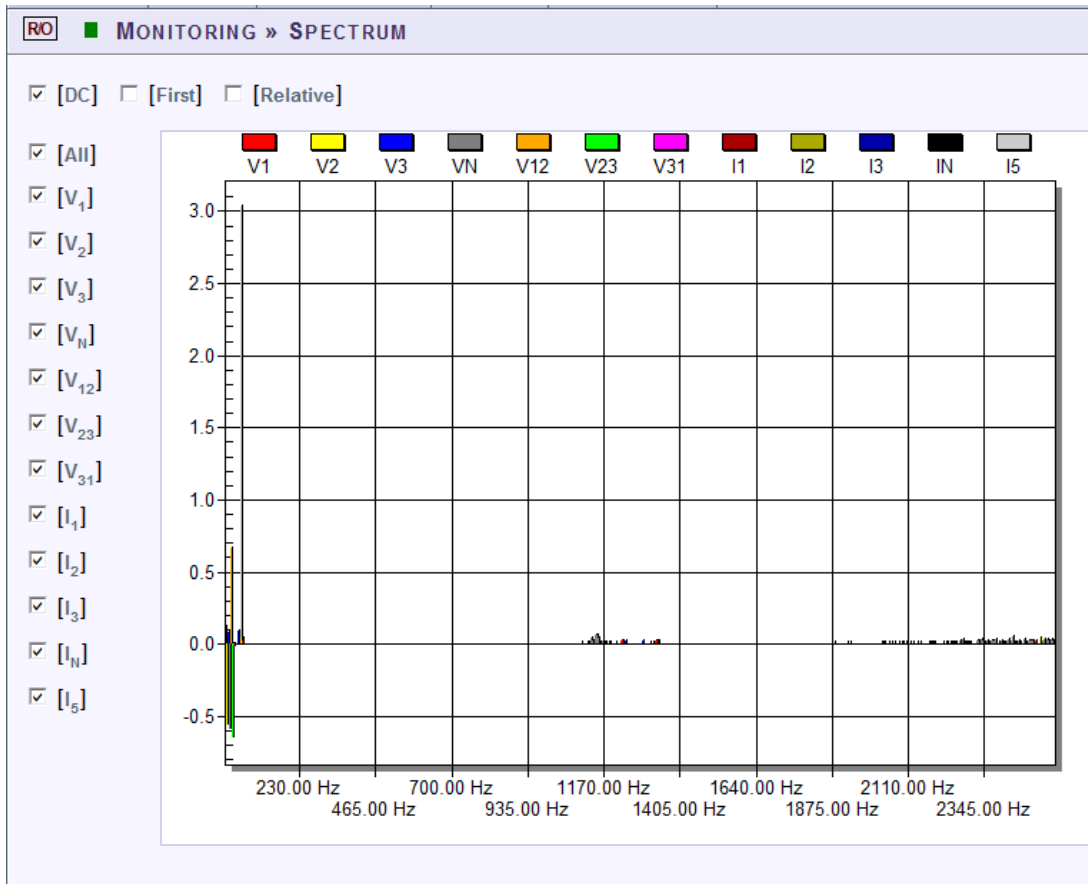
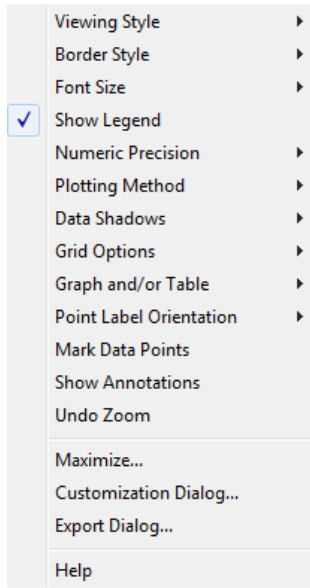

TABLE - SPECTRUM WINDOW OPTIONS:

The table outlines the sections' Parameter options (for your selection) including their Definition:

Parameter	Definition
DC	Check/Uncheck the checkbox in order to display/not display the DC Harmonics
First	Check/Uncheck the checkbox in order to display/not display the First Harmonic
Relative	Check/Uncheck the checkbox in order to display/not display the harmonics relative to the first harmonic (Whereas the first harmonic is 100, and the other harmonic values as part of the harmonic 100)
All	Checking the "All" will display all the channels
Voltage & Current	Select the applicable Voltage / Current channel to be displayed

CHART OPTIONS:

- By right-clicking on the chart you have various chart options & capabilities available to you:



- Viewing Style:** Different styling options Color / Monochrome (B&W) with/without Symbols / Bitmap etc. By selecting the option you can view on screen the different styles available to you
- Border Style:** No Border, Thin Line, Shadow / Inset
- Font Size:** Large / Medium / Small
- Display / Not display Legend**
- Numeric Precision:** No up to 3 Decimals
- Plotting Method:** From Line / Bar / Point / Area / Spline / Combinations
- Data Shadows:** Off / Shadow / 3D
- Grid Options:** Various grid options ranging from dots / lines / different axis etc.
- Graph & Table:** Display either the graph / table / both:

	291.40 Hz	328.60 Hz	365.80 Hz	403.00 Hz	440.20 Hz	477.40 Hz						
	310.00 Hz	347.20 Hz	384.40 Hz	421.60 Hz	458.80 Hz	496.00 Hz						
V1	0.000	0.002	0.004	0.022	0.003	0.002	0.002	0.003	0.004	0.002	0.000	0.001
V2	0.000	0.001	0.003	0.017	0.002	0.002	0.001	0.003	0.001	0.001	0.000	0.001
V3	0.001	0.001	0.003	0.027	0.004	0.002	0.002	0.002	0.003	0.003	0.001	0.001

- Point Label Orientation:** Auto / Vertical / Horizontal / Slanted
- Mark Data Points:** Displays data points on graph
- Show Annotations:** Displays annotations data descriptions
- Zoom / Undo Zoom - Zoom in /out on your graph:**
 - From the main Waveform window, select an area to zoom in. Left-click and drag the mouse to define the area:

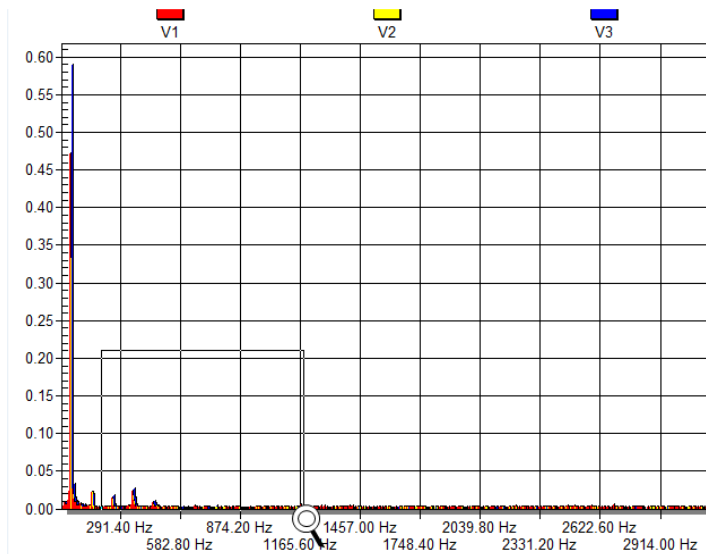

- The enlarged area will now appear in the window
- Zoom out by right/click ➔ & select **Zoom out**
- **Maximize:** Maximize / Minimize graph
- **Customization Dialog - Various General Graph Customization Options** (all options apart from zooming above):

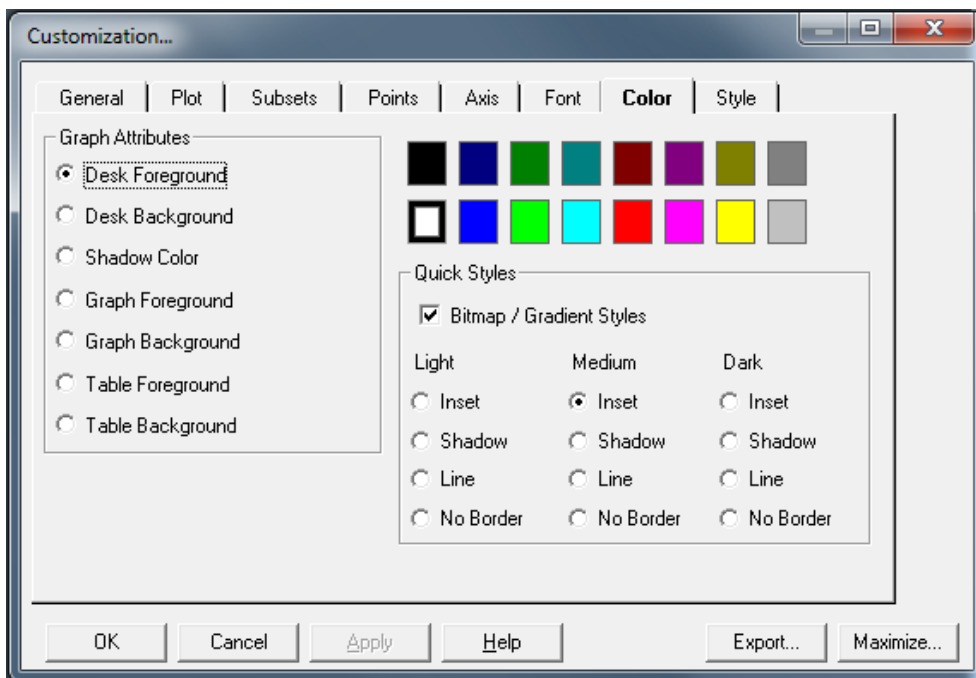

- **Export Dialog - Various Export Options:**

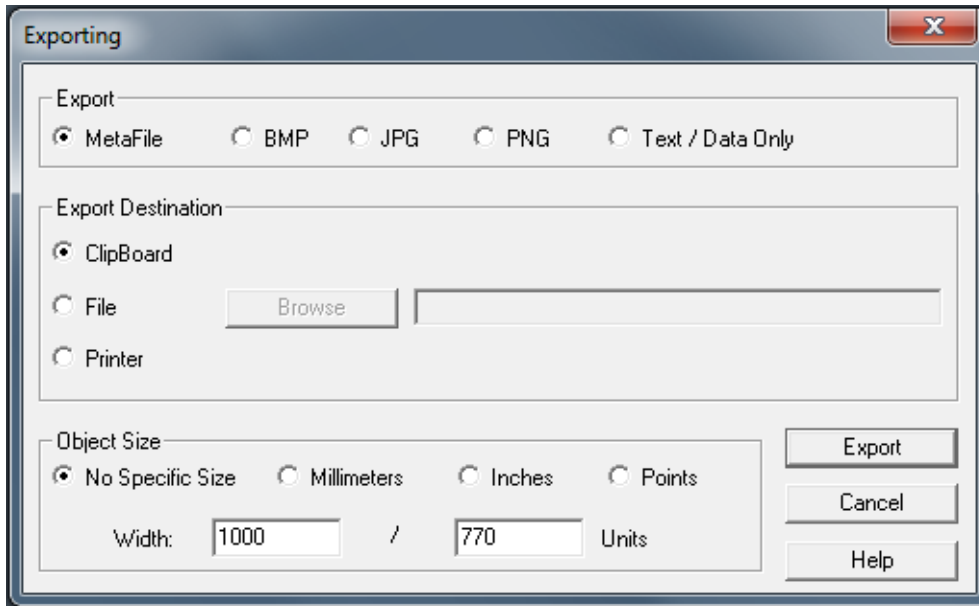

SEE ALSO:

- [About PQ Monitoring](#)
- [Voltage & Current](#)
- [Averaging](#)
- [Power](#)
- [Temperature](#)
- [Phasors](#)
- [Waveforms](#)
- [Voltage Flickering](#)
- [Pinst Waveforms](#)
- [Min/Max Flickering](#)
- [V&I Harmonics](#)
- [P&Q Harmonics](#)
- [Harmonics Table](#)
- [V/I Min/Max Harmonics](#)
- [P/Q Min/Max Harmonics](#)

Harmonics Table

This page summarizes all the Voltage & Current Harmonics in either Values, % or Angles - up to the 50th Harmonic.

OPEN THE HARMONICS TABLE WINDOW:

- [Access your Portable BLACKBOX Unit](#) via the Web Interface → select **Monitoring** → **Harmonics Table:**

MONITORING	ENERGY	POWER QUALITY
Summary	V & I harmonics	
Voltage & Current	P & Q harmonics	
Average	Spectrum	
Power	<u>Harmonics Table</u>	
Temperature	V/I Min/Max Harmonics	
Phasors	P/Q Min/Max Harmonics	
Waveforms		
Voltage Flickering		
Pinst Waveform		
Min/Max Flickering		

- The **Harmonics Table Window** will now open:

MONITORING » HARMONICS TABLE			
	150/180 Cycles	10 Min.	2 Hours
Timestamp	25/12/2011 17:09:09	25/12/2011 17:00:00	DD/MM/YYYY HH:MM:SEC
Flag	Not flagged	Flagged: V1,V2,V3	Not flagged

Measurement Type: Harmonics

- Harmonics
- Interharmonics
- 150/180 Cycles Harmonic
- 150/180 Cycles Interharmonic
- 10 min Harmonic
- 10 min Interharmonic
- 2 hour Harmonic
- 2 hour Interharmonic
- Spectrum
- Harmonic's Angle

Range: 1 - 128

[Relative]

V & I Harmonics													
	V ₁	V ₂	V ₃	V _N	V ₁₂	V ₂₃	V ₃₁	I ₁	I ₂	I ₃	I _N	I ₁₂	I ₂₃
H ₁	230.664 V	229.417 V	230.642 V	0.018 V	1.231 V	1.227 V	0.011 V	0 A	0 A	0.003 A	3.974 A	0	0
H ₂	0 V	0 V	0 V	0.001 V	0.003 V	0.001 V	0.001 V	0 A	0 A	0.018 A	0.11 A	0	0
H ₃	0 V	0 V	0 V	0.001 V	0.002 V	0.001 V	0.003 V	0 A	0 A	0.001 A	0.011 A	0	0
H ₄	0 V	0 V	0 V	0.002 V	0.001 V	0.002 V	0.002 V	0 A	0 A	0.006 A	0.046 A	0	0
H ₅	0 V	0 V	0 V	0.002 V	0.002 V	0.003 V	0.002 V	0 A	0 A	0.001 A	0 A	0	0
H ₆	0 V	0 V	0 V	0.002 V	0.002 V	0.003 V	0.001 V	0 A	0 A	0.002 A	0.011 A	0	0
H ₇	0 V	0 V	0 V	0.003 V	0.001 V	0.001 V	0.001 V	0 A	0 A	0.001 A	0 A	0	0
H ₈	0 V	0 V	0 V	0.002 V	0.002 V	0.002 V	0.002 V	0 A	0 A	0.004 A	0 A	0	0
H ₉	0 V	0 V	0 V	0.002 V	0.001 V	0.003 V	0.003 V	0 A	0 A	0 A	0 A	0	0
H ₁₀	0 V	0 V	0 V	0.003 V	0.001 V	0.001 V	0.001 V	0 A	0 A	0.001 A	0 A	0	0
H ₁₁	0 V	0 V	0 V	0.005 V	0.003 V	0.001 V	0.002 V	0 A	0 A	0.001 A	0 A	0	0
H ₁₂	0 V	0 V	0 V	0.005 V	0.002 V	0.002 V	0.001 V	0 A	0 A	0.001 A	0 A	0	0
H ₁₃	0 V	0 V	0 V	0.003 V	0.002 V	0.003 V	0.001 V	0 A	0 A	0.001 A	0 A	0	0
H ₁₄	0 V	0 V	0 V	0.002 V	0.002 V	0.002 V	0.001 V	0 A	0 A	0.001 A	0 A	0	0

TABLE - HARMONICS MEASUREMENT TYPE, RANGE & WINDOW OPTIONS:

The table outlines the sections' Parameters including Definition:

Parameter	Definition
Timestamp	Indicates the timestamps of the last averaging intervals
Flag	Indicates whether or not the last interval is valid according to the set standard
MEASUREMENT TYPE	
Harmonics	Real time (10/12 cycles) calculation of sub group harmonics, in accordance with IEC61000-4-7: $G_{sg,n}^2 = \sum_{i=1}^1 C_{k+i}^2$
Interharmonics	Real time (10/12 cycles) calculation of inter sub group harmonics, in accordance with IEC61000-4-7

150/180 Cycles Harmonic	150/180 Cycle averaging of the sub group harmonics
150/180 Cycles Interharmonic	150/180 Cycle averaging of the inter sub group harmonics
10 Min Harmonic	10 Minutes averaging of the sub group harmonics
10 Min Interharmonic	10 Minutes averaging of the inter sub group harmonics
2 Hour Harmonic	2 Hours averaging of the 10 minutes averaging of the sub group harmonics
2 Hour Interharmonic	2 Hours averaging of the 10 minutes averaging of the inter sub group harmonics
Harmonic's Angle	The angle of each harmonic based on the real time value
RANGE	
1-128	Select the number of harmonics to be displayed 1-128
129-256	Select the number of harmonics to be displayed 129-256
257-384	Select the number of harmonics to be displayed 257-384
1-50	Select the number of harmonics to be displayed 285-511

OPTIONS	
First	Check/Uncheck the checkbox in order to display/not display the First Harmonic
Relative	Check/Uncheck the checkbox in order to display/not display the harmonics relative to the first harmonic (Whereas the first harmonic is 100, and the other harmonic values as part of the harmonic 100)
All	Checking the "All" will display all the channels
Voltage & Current	Select the applicable Voltage / Current channel to be displayed

SEE ALSO:

- [About PQ Monitoring](#)
- [Voltage & Current](#)
- [Averaging](#)
- [Power](#)
- [Temperature](#)
- [Phasors](#)
- [Waveforms](#)
- [Voltage Flickering](#)
- [Pinst Waveforms](#)
- [Min/Max Flickering](#)
- [V&I Harmonics](#)
- [P&Q Harmonics](#)
- [Spectrum](#)
- [V/I Min/Max Harmonics](#)
- [P/Q Min/Max Harmonics](#)

Voltage & Current, Min & Max Harmonics Table

For each Harmonic, there is a Minimum & Maximum value for Voltage & Current. Voltage values are seen as phase to phase, while currents are displayed in both phase to neutral and phase to phase combinations. This page summarizes all the minimum Voltage & Current Harmonics Values.

OPEN THE V/I MIN/MAX HARMONICS WINDOW:

- [Access your Portable BLACKBOX Unit](#) via the Web Interface ➡ select **Monitoring** ➡ **V/I Min/Max Harmonics**:

MONITORING	ENERGY	POWER QUALITY
Summary		V & I harmonics
Voltage & Current		P & Q harmonics
Average		Spectrum
Power		Harmonics Table
Temperature		V/I Min/Max Harmonics
Phasors		P/Q Min/Max Harmonics
Waveforms		
Voltage Flickering		
Pinst Waveform		
Min/Max Flickering		

- The window containing the table for V/I Min/Max Harmonics values will now open:

RO ■ MONITORING » V/I MIN/MAX HARMONICS

[Harmonic's Angle] [Harmonics] **Reset All Min/Max**

Hamonics Min & Max

		V ₁	V ₂	V ₃	V _N	V ₁₂	V ₂₃	V ₃₁	I ₁	I ₂	I ₃	I _N
H ₁	Min.	0 °	0 °	0 °	0 °	0 °	0 °	0 °	0 °	0 °	0 °	0 °
	Max.	0 °	0 °	0 °	0 °	0 °	0 °	0 °	0 °	0 °	0 °	0 °
H ₂	Min.	93.78 °	97.44 °	93.38 °	97.12 °	92.39 °	92.54 °	92.86 °	104.98 °	98.13 °	93.58 °	95.12 °
	Max.	-24.48 °	-26.49 °	-21.7 °	88.19 °	84.28 °	88.36 °	83.97 °	86.83 °	87.5 °	70.45 °	60.12 °
H ₃	Min.	-89.99 °	-89.59 °	-89.73 °	-176.19 °	-178.49 °	-175.91 °	-177.79 °	-135 °	-174.81 °	-177.4 °	-176.12 °
	Max.	140.65 °	140.65 °	137.85 °	177.63 °	174.27 °	171.82 °	163.25 °	158.63 °	152.89 °	176 °	170.12 °
H ₄	Min.	-86.89 °	-87.72 °	-87.21 °	-88.09 °	-88.75 °	-86.82 °	-88.96 °	-83.12 °	-83.66 °	-88.02 °	-86.12 °
	Max.	-95.43 °	-94.53 °	-101.44 °	-91.19 °	-96.03 °	-115.36 °	-91.57 °	-99.11 °	-134.45 °	-99.16 °	-106.12 °
H ₅	Min.	116.51 °	97.96 °	116.51 °	3.58 °	0.78 °	1.45 °	7.2 °	18.43 °	7.12 °	1.04 °	3.51 °
	Max.	-80.89 °	-74.12 °	-84.28 °	-1.45 °	-9.99 °	-10.23 °	-2.48 °	-10.29 °	-23.82 °	-8.53 °	-1.12 °
H ₆	Min.	-174.43 °	149.46 °	154.84 °	92.39 °	92.95 °	91.33 °	97.75 °	98.43 °	99.46 °	91.74 °	92.12 °
	Max.	15.63 °	-14.95 °	37.3 °	84.13 °	73.09 °	79.68 °	85.22 °	82.94 °	33.23 °	63.28 °	71.12 °
H ₇	Min.	-178.13 °	-178.32 °	-179.14 °	-177.51 °	-178.34 °	-179.32 °	-176.69 °	-153.44 °	-171.87 °	-169.38 °	-174.12 °
	Max.	179.37 °	179.48 °	179.27 °	176.13 °	165.41 °	173.73 °	177.76 °	81.75 °	146.65 °	153.25 °	178.12 °
Min.	00.5 °	02.11 °	05.02 °	07.71 °	00.14 °	00.67 °	01.71 °	15.00 °	00.51 °	07.0 °	05.12 °	

Hamonics Min & Max

		V ₁	V ₂	V ₃	V _N	V ₁₂	V ₂₃	V ₃₁	I ₁	I ₂	I ₃	I _N
H ₁	Min.	1.287628 V	1.288697 V	1.293045 V	0.002159 V	0.00343 V	0.005256 V	0.003022 V	0 A	0	0	0
	Max.	230.6672 V	229.437 V	230.667 V	0.031521 V	1.234189 V	1.234486 V	0.011978 V	49.98149 A	1.3615	0	0
H ₂	Min.	0 V	0 V	0 V	0.002119 V	0.002609 V	0.002537 V	0.00139 V	0 A	0	0	0
	Max.	23.91226 V	23.78756 V	23.91302 V	0.028436 V	0.128162 V	0.128562 V	0.003188 V	0.777501 A	600.6	0	0
H ₃	Min.	0 V	0 V	0 V	0.00206 V	0.002596 V	0.002532 V	0.001639 V	0 A	0	0	0
	Max.	11.50778 V	11.44594 V	11.50907 V	0.02824 V	0.061861 V	0.061923 V	0.003594 V	0.721345 A	399.1	0	0
H ₄	Min.	0 V	0 V	0 V	0.002294 V	0.002534 V	0.002504 V	0.001345 V	0 A	0	0	0
	Max.	7.833364 V	7.79287 V	7.836477 V	0.028228 V	0.042604 V	0.042458 V	0.003215 V	0.506629 A	294.4	0	0
H ₅	Min.	0 V	0 V	0 V	0.002201 V	0.002778 V	0.003358 V	0.001461 V	0 A	0	0	0
	Max.	6.004971 V	5.971307 V	6.0015 V	0.029449 V	0.033039 V	0.033173 V	0.003276 V	0.248671 A	238.4	0	0
H ₆	Min.	0 V	0 V	0 V	0.002636 V	0.002497 V	0.00253 V	0.001401 V	0 A	0	0	0
	Max.	4.886686 V	4.863055 V	4.888101 V	0.0256 V	0.026715 V	0.026827 V	0.00313 V	0.248222 A	185.5	0	0
H ₇	Min.	0 V	0 V	0 V	0.002319 V	0.002571 V	0.0026 V	0.001429 V	0 A	0	0	0
	Max.	4.135073 V	4.116119 V	4.137125 V	0.022718 V	0.023099 V	0.023076 V	0.003221 V	0.278355 A	162.7	0	0
Min.	0 V	0 V	0 V	0.00272 V	0.002577 V	0.002571 V	0.001450 V	0 A	0	0	0	

TABLE - V/I MIN/MAX HARMONICS WINDOW OPTIONS:

The table outlines the sections' Parameters including Definition:

Parameter	Definition
Harmonics Angle	Check in order to display the Min/Max value of the Harmonics Angle
Harmonics Value	Check in order to display the Min/Max value of the Harmonics Value (amplitude)
Reset All Min/Max	Reset all Min/Max measurements of your G4K Unit

SEE ALSO:

- [About PQ Monitoring](#)
- [Voltage & Current](#)
- [Averaging](#)
- [Power](#)
- [Temperature](#)
- [Phasors](#)
- [Waveforms](#)
- [Voltage Flickering](#)
- [Pinst Waveforms](#)
- [Min/Max Flickering](#)
- [V&I Harmonics](#)
- [P&Q Harmonics](#)
- [Spectrum](#)
- [Harmonics Table](#)
- [P/Q Min/Max Harmonics](#)

PQ Min & Maximum Harmonics

This page summarizes all the minimum & maximum Active & Reactive Power Harmonic Values per phase, up to the 50th Harmonic.

- (P) = Active Power Harmonic Values
- (Q) = Reactive Power Harmonic Values

OPEN THE P/Q MIN/MAX HARMONICS WINDOW:

- [Access your Portable BLACKBOX Unit](#) via the Web Interface → select **Monitoring** → **P/Q Min/Max Harmonics**:

MONITORING	ENERGY	POWER QUALITY
Summary	V & I harmonics	
Voltage & Current	P & Q harmonics	
Average	Spectrum	
Power	Harmonics Table	
Temperature	V/I Min/Max Harmonics	
Phasors	P/Q Min/Max Harmonics	
Waveforms		
Voltage Flickering		
Pinst Waveform		
Min/Max Flickering		

- The window containing the table for **P/Q Min/Max Harmonics** values will now open:

RO ■ MONITORING » P/Q MIN/MAX HARMONICS

[Reset All Min/Max](#)

P & Q min-max harmonics

		P ₁	P ₂	P ₃	P _N	Q ₁	Q ₂	Q ₃
H ₁	Min.	-11.53151 kW	-1.292078 kW	-7.045688 kW	-0.012678 kW	-0.259262 kVAr	-1.814383 kVAr	-86.06764 kVAr
	Max.	0.115775 kW	6.877967 kW	58.50917 kW	0.005459 kW	0.135138 kVAr	0.320006 kVAr	2.26808 kVAr
H ₂	Min.	-0.000043 kW	-0.012867 kW	-0.084672 kW	-0.000004 kW	-0.000103 kVAr	-0.006906 kVAr	-0.554016 kVAr
	Max.	0.000177 kW	0.00779 kW	0.005552 kW	0.0001 kW	0.000031 kVAr	0.003608 kVAr	0.01 kVAr
H ₃	Min.	-0.000013 kW	-0.013526 kW	-0.163703 kW	-0.000115 kW	-0.000033 kVAr	-0.003281 kVAr	-0.025685 kVAr
	Max.	0.000023 kW	0.013736 kW	0.078375 kW	0.000125 kW	0.000009 kVAr	0.032922 kVAr	0.834281 kVAr
H ₄	Min.	-0.000007 kW	-0.000243 kW	-0.05025 kW	-0.00004 kW	-0.000001 kVAr	-0.000404 kVAr	-0.014062 kVAr
	Max.	0.000006 kW	0.001286 kW	0.010813 kW	0.000015 kW	0.000002 kVAr	0.000824 kVAr	0.007379 kVAr
H ₅	Min.	-0.000005 kW	-0.003377 kW	-0.621641 kW	-0.000039 kW	0 kVAr	-0.007551 kVAr	-0.032422 kVAr
	Max.	0.000004 kW	0.013598 kW	0.089625 kW	0.000018 kW	0.000004 kVAr	0.007218 kVAr	0.424844 kVAr
H ₆	Min.	-0.000003 kW	-0.000407 kW	-0.048844 kW	-0.00001 kW	0 kVAr	-0.000917 kVAr	-0.012219 kVAr
	Max.	0.000002 kW	0.000414 kW	0.002672 kW	0.000029 kW	0.000003 kVAr	0.000146 kVAr	0.007813 kVAr
H ₇	Min.	-0.000002 kW	-0.00246 kW	-0.021586 kW	-0.00002 kW	-0.000001 kVAr	-0.002191 kVAr	-0.014266 kVAr
	Max.	0.000001 kW	0.003882 kW	0.017531 kW	0.000002 kW	0.000001 kVAr	0.003442 kVAr	0.023969 kVAr

TABLE - P/Q MIN/MAX HARMONICS WINDOW OPTIONS:

The table outlines the sections' Parameters including Definition:

Parameter	Definition
P1	Displays the Active Power (P) of the first line
P2	Displays the Active Power (P) of the second line
P3	Displays the Active Power (P) of the third line
Q1	Displays the Reactive Power (Q) of the first line
Q2	Displays the Reactive Power (Q) of the second line
Q3	Displays the Reactive Power (Q) of the third line
Reset All Min/Max	Reset all Min/Max measurements of your Portable PQ Analyzer

SEE ALSO:

- [About PQ Monitoring](#)
- [Voltage & Current](#)
- [Averaging](#)
- [Power](#)
- [Temperature](#)
- [Phasors](#)
- [Waveforms](#)
- [Voltage Flickering](#)
- [Pinst Waveforms](#)
- [Min/Max Flickering](#)
- [V&I Harmonics](#)
- [P&Q Harmonics](#)
- [Spectrum](#)
- [Harmonics Table](#)
- [Voltage & Current, Min & Max Harmonics Table](#)

About Monitoring Power Quality

The BLACKBOX contains a power quality compliance engine that enables real-time evaluation of power quality according to standards such as EN50160. Power Quality (PQ) Compliance is a set of electrically measured parameters which are typically calculated based on some pre-defined intervals or event triggers and are evaluated over a large observation window. For most of the PQ parameters, the observation window is one week, which means the displayed online information refers to the previous week. However, using ELSPEC's PQSCADA and Investigator applications, all time intervals are able to be observed.

A PQ parameter is typically based on a power quality event. For example, the DIP PQ parameter is based on counting DIP events over some observation period.

Different national standards vary in the way a specific PQ parameter is being measured or observed. The PQ Engine also supports a mode that can be customized by the user, in which all compliance parameters can be self-edited and modified by a user in order to meet new conditions, rules, measuring intervals, and even different observation periods.

The Power Quality section in Elspec's Web Interface is used to control and view power quality measurement and compliance information computed by the PQ Engine that includes:

- [View & Evaluate Summary of the Compliance Engine](#)
- [View Detailed Compliance Information](#)
- [View Graphical Bars of Compliance Levels](#)
- [Set & View Log of Events](#)

PQ Compliance Summary

In this window you are able to review the specific **Compliance Standard & Status** that is being evaluated by your G4500/G3500 Portable BLACKBOX's Internal Compliance Engine.

Open the compliance SUMMARY WINDOW:

- Access your [Portable BLACKBOX Unit](#) → log on as the **Viewer/Administrator** → under **Power Quality** → open the **Summary Tab**:



- The **Summary** window will now open:

Event Status		Compliance Summary	
Voltage Frequency	OK	Compliance Type	EN50160
Supply Voltage Variations	OK	Running Status	Running
Rapid Voltage Changes	OK	Embedded Report	None
Supply Voltage Dips	FAIL	Evaluation Status	N/A
Short Interruptions	OK	Start Time	22/12/2011 15:23:30
Long Interruptions	OK	Window Time On	3:2:20:52 D:H:M:S
Temporary Overvoltage	OK	Window Time Off	0:0:3:36 D:H:M:S
Flicker Severity	OK	Measurement Flag	Not flagged
Harmonic Voltage	OK		
Supply Voltage Unbalance	OK		

EVENTS STATUS SCREEN:

The Events Status Table shows a high level PASS or FAIL indication of each PQ parameter. Any PQ parameter that has an incomplete observation period will be presented as N/A (Not Available). The definitions defined below are PQ Parameters configured as per EN50160 compliance (as per the example used for the Compliance Information Window). You may choose any other PQ Compliance or set your own unique PQ Compliance:

- **Voltage Frequency OK/FAIL:** Frequency compliance is based on statistics: N, N1 & N2. Frequency measurement interval is 10 sec. in an entire observation window of 1 week. N - amount of intervals. N1 - intervals frequency exceeded [+1.00%,-1.00%] from Nominal Frequency. N2 - intervals frequency exceeded [+4.00%,-6.00%] from Nominal Frequency. N1 & N2 increment only if valid voltage inside nominal boundary of [+15.0%,-15.0%]. Compliance if both $N1/N < 5.0\%$ of time and $N2 = 0$ of time. Intervals with voltage interruption are discarded. Intervals with DIPS or Over voltage are discarded.
- **Supply Voltage Variations OK/FAIL:** Variations are evaluated by collecting statistics: N, N1 & N2. Statistics are collected as average voltage within intervals of 10 min. in observation window of 1 week. N - amount of intervals. N1 - intervals voltage exceeded [+10.0%,-10.0%] boundary of nominal. N2 - intervals voltage exceeded [+15.0%,-15.0%] boundary of nominal. Compliance if $N1/N \leq 5\%$ & $N2=0$ during the entire observation window. Intervals with voltage interruption are discarded. Intervals with DIPS or OVER Voltage are discarded.
- **Rapid Voltage Changes OK/FAIL:** Rapid voltage change is based on a 3 sec. window in which RMS voltage minimum & maximum values are obtained (minimum/maximum values should be within $\pm 10.0\%$ from nominal). The rapid change is the percent of delta between minimum & maximum divided by average RMS of 9 sec. The Rapid percent results are evaluated during observation window of 1 week. Rapid changes are limited to specific count (N): Rapids of more 5.00% allowed: $N \leq 65536$ occurrences.
- **Supply Voltage Dips OK/FAIL:** DIP is a voltage drop of more than 10.0% from Nominal (but no more than 100.0%, & deactivate on 8.0%) DIP minimum time is 10 ms. & maximum time of 1 min. DIP events are counted per all phases combined within observation window of 1 week. Total events (N) allowed is: 20.
- **Short Interruptions OK/FAIL:** Short interruption is a voltage drop of less than 97.0% from nominal (event deactivate on 77.6%). Min duration 10 ms., Max duration 3 min. events are counted in the entire observation window of 1 week. Total events (N) allowed is: 2.
- **Long Interruptions OK/FAIL:** Long interruptions are the same as short ones but with a longer duration (longer than short interruption maximum time). Long interruptions events are counted within observation window of 1 week. Total events (N) allowed is: 1.
- **Temporary Overvoltage OK/FAIL:** Over-voltage events are characterized with RMS voltage higher than 10.0% above Nominal (event deactivate on 8.0%). Minimum over-voltage event duration is 10 ms., events are counted per all phases combined within observation window of 1 week. No specific events count limitation is defined.
- **Flicker Severity OK/FAIL:** Flicker severity is evaluated within observation window of 1 week. During interruption Flicker interval is discarded. During DIPS or Over voltage Flicker Interval is discarded. Plt (2 hours) must be equal or under 1.0 during 95.0% of observation time.
- **Harmonic Voltage OK/FAIL:** Harmonics evaluated at intervals of 10 min. within observation window of 1 week. Evaluation at intervals in which voltage is inside nominal boundary of [+15.0%,-15.0%]. Discarding Intervals with VOLT-INT. Discarding Intervals with DIPS or OVER-VOLT. Individual Harmonics are limited according to the following table: $H2 \leq 2.0\%$, $H3 \leq 5.0\%$, $H4 \leq 1.0\%$, $H5 \leq 6.0\%$, $H6 \leq 0.5\%$, $H7 \leq 5.0\%$, $H8 \leq 0.5\%$, $H9 \leq 1.5\%$, $H10 \leq 0.5\%$, $H11 \leq 3.5\%$, $H12 \leq 0.5\%$, $H13 \leq 3.0\%$, ... THD limit is set 8.0% (N2). THD and Harmonics limits shall be kept at least 95.0% of time.

- **Supply Voltage Unbalance OK/FAIL:** Voltage unbalance is evaluated at intervals of 10 min. within observation window of 1 week. Evaluation is only at intervals in which voltage is inside nominal boundary of [+15.0%,-15.0%]. Unbalance limit N1 is set to 2.00% and must be kept 95.0% of observation time. Intervals with voltage interruption are discarded. Intervals with DIPS or Over voltage are discarded.

COMPLIANCE SUMMARY SECTION:

- **The Compliance Type** is configured when Setting your Instrument in PQ Compliance Configuration.
- **Running Status** means whether or not the BLACKBOX's Power Quality engine is evaluating the power quality according to the Configured PQ Compliance.
- **The Embedded Report** field further indicates a type of report that is auto-generated internally in the device's file system. Most compliance types do not generate any specific report, & therefore, the report type will be **None**. However, CREG type of compliance (used in Colombia) also auto-generates a specific format of Report Files as defined by the local regulator.
- **The Evaluation Status** field provides an overall status of PASS or FAIL of the entire compliance. Anytime the evaluation period is not complete (typically required is a 1 week observation), the status will be **N/A** (Not Available), otherwise PASS will be indicated as **OK**.
- **The Start Time** field shows the last time the compliance engine was restarted. The entire state & observation window history is stored on the internal non-volatile memory, so even after powering down; the Engine will continue its evaluation & maintain all indications. (Start time remains unchanged after device powered up.)
- **The Window Time On/Off** fields specify how much aggregated time is already in the observation window. **ON** refers to the aggregated window time the device was powered on & **OFF** refers to the amount of window time the device power was off. The format presented is [Days: Hours: Minutes: Seconds]. Ideally the **OFF** time is all zeroes & the **ON** time is 7 days (which is the typical full observation period in most of the compliance types). Once the observation window reaches 7 days, it will start to slide in steps of 2 hours. Sliding means the information from the oldest 2 hours is being dropped, where a new up-to-date 2-hour interval is being used for calculations.
- **The Measurement Flag** field indicates whether there is a power quality event such as a **DIP/SWELL** or **INTERRUPTION** at the moment.

NOTE NOTE NOTE

All underlined parameters are accompanied by a Tool Tip, Right-click on the ? to open the Tool Tip & x to close the Pop-up:

<u>Supply Voltage Dips</u>	N/A
<u>Short Interruptions</u>	Supply Voltage Dips DIP is a voltage drop of more than 10.0% from Nominal (but no more than 100.0%, and deactivate on 8.0%) DIP min time is 10 ms and max time of 1 min. DIP events are counted per all phases combined within observation window of 1 week. Total events (N) allowed is: 20.
<u>Long Interruptions</u>	
<u>Temporary Interruptions</u>	

SEE ALSO:

- [About PQ Monitoring](#)
- [Compliance Info](#)
- [Compliance Chart](#)
- [Events](#)
- [PQ Compliance Configuration](#)

Compliance Information

This window contains detailed compliance information.

access the Compliance information window:

- Access your Portable BLACKBOX Unit → log on as the Administrator → under Summary → open the Information Tab:

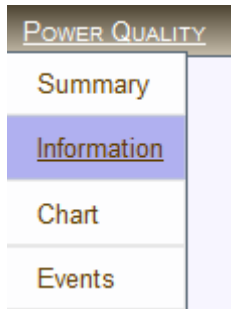

- The Information window will now open:

RO ■ POWER QUALY » INFORMATION						
Detailed Compliance Info						Compliance Status: Running
	Status	Observation	Window Interval	Time OK	Time N/A	Total Events
	Partial			Time Fail		
Voltage Frequency	N/A OK	Incomplete	1 week 10 sec	99.996 % 0.0040 %	0.0806 %	1
Supply Voltage Variations	N/A OK	Incomplete	1 week 10 min	100.000 % 0.0000 %	0.0806 %	0
Rapid Voltage Changes	N/A OK	Incomplete	1 week 3 sec	99.976 % 0.0236 %	0.0806 %	7
Supply Voltage Dips	N/A OK	Incomplete	1 week 10 ms	92.105 % 7.8947 %	0.0806 %	13
Short Interruptions	N/A FAIL	Incomplete	1 week 10 ms	92.105 % 7.8947 %	0.0806 %	20
Long Interruptions	N/A FAIL	Incomplete	1 week 10 ms	92.167 % 7.8328 %	0.0806 %	4
Temporary Overvoltage	N/A OK	Incomplete	1 week 10 ms	100.000 % 0.0000 %	0.0806 %	0
Flicker Severity	N/A OK	Incomplete	1 week 10 min	97.143 % 2.8571 %	0.0806 %	1
Harmonic Voltage	N/A OK	Incomplete	1 week 10 min	99.756 % 0.2439 %	0.0806 %	1
Supply Voltage Unbalance	N/A OK	Incomplete	1 week 10 min	100.000 % 0.0000 %	0.0806 %	0

- Status/Partial:** Contains two status indicators. The upper indicator refers to the entire observation window's PASS/FAIL result (same status as presented in the Summary page),

while the lower indicator is a PASS/FAIL indicator of the most recent period. This recent indicator serves as real-time indicator & typically reflects to only minutes to a few hours of history (this is dependent on the specific PQ parameter measurement intervals & method).

- **Observation:** Indicates whether the observation window of a specific PQ parameter is complete.
- **Window/Interval:** Upper Area - Provides the observation window time (contains historical data used for the calculations). You may uniquely set the observation period in User Defined Pages (Options - 1 or 2 Hours, or 1 Day, or 1 Week, or 1 Year). Lower Area - Provides the measurement interval time or parameter resolution that falls within the observation window (the measured time length for the PQ parameter). The interval may also be set in User Defined Pages (Options - 1, 3, 10 or 20 seconds, or 1, 3, 10 or 30 minutes, or 1, or 2 Hours, or 1 Day). If you [Configure your PQ Compliance](#) to a set standard (i.e. EN50160), the Observation Window & Interval Time will be calculated according to the standard.
 - **Time OK/Time FAIL:** provides the percentage of time the PQ parameter was OK (as green text on the upper area) & percentage of time the PQ parameter was outside the defined limits or FAILED (as red text in the lower area) for the entire observation period (Observation Window). Example as per the Information Window: if Flicker Severity was observed for a period of 1 week at a resolution of 10 min (interval), the PQ parameter was OK for 97.143% & FAILED for 2.8571% of the time (observation week). It should not be confused to the lower area on the previous column.
 - **Time N/A:** Provides the percentage of time the unit was not measuring due to lack of power.
 - **Total Events:** Provides the overall number of PQ events influenced by the PQ parameter in the observation window.

Note Note Note

All underlined parameters are accompanied by a Tool Tip, Right-click on the ? to open the Tool Tip & x to close the Pop-up:

<u>Temporary Overvoltage</u>	<u>N/A</u>	<u>Incomplete</u>	<u>1 week</u>
<u>Flicker Se</u>			
<u>Harmonic V</u>			

Temporary Overvoltage
 Over-voltage events are characterized with RMS voltage higher than 10.0% above Nominal (event deactivate on 8.0%). Min over-voltage event duration is 10 ms, events are counted per all phases combined within observation window of 1 week. No specific events count limitation defined.

SEE ALSO:

- [About PQ Monitoring](#)
- [Compliance Summary](#)
- [Compliance Chart](#)
- [Events](#)
- [PQ Compliance Configuration](#)

Compliance Chart

This page displays graphical bars of compliance levels (equals to percentage of time OK). This screen is most helpful as you can immediately ascertain the status of compliance to PQ Standards.

access the Compliance CHART window:

- [Access your Portable BLACKBOX Unit](#) → log on as the **Viewer/Administrator** → under **Power Quality** → open the **Chart Tab**:

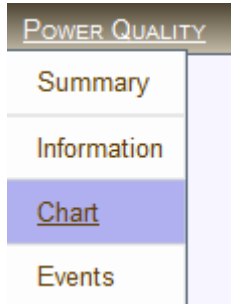

- The **Information** window will now open:

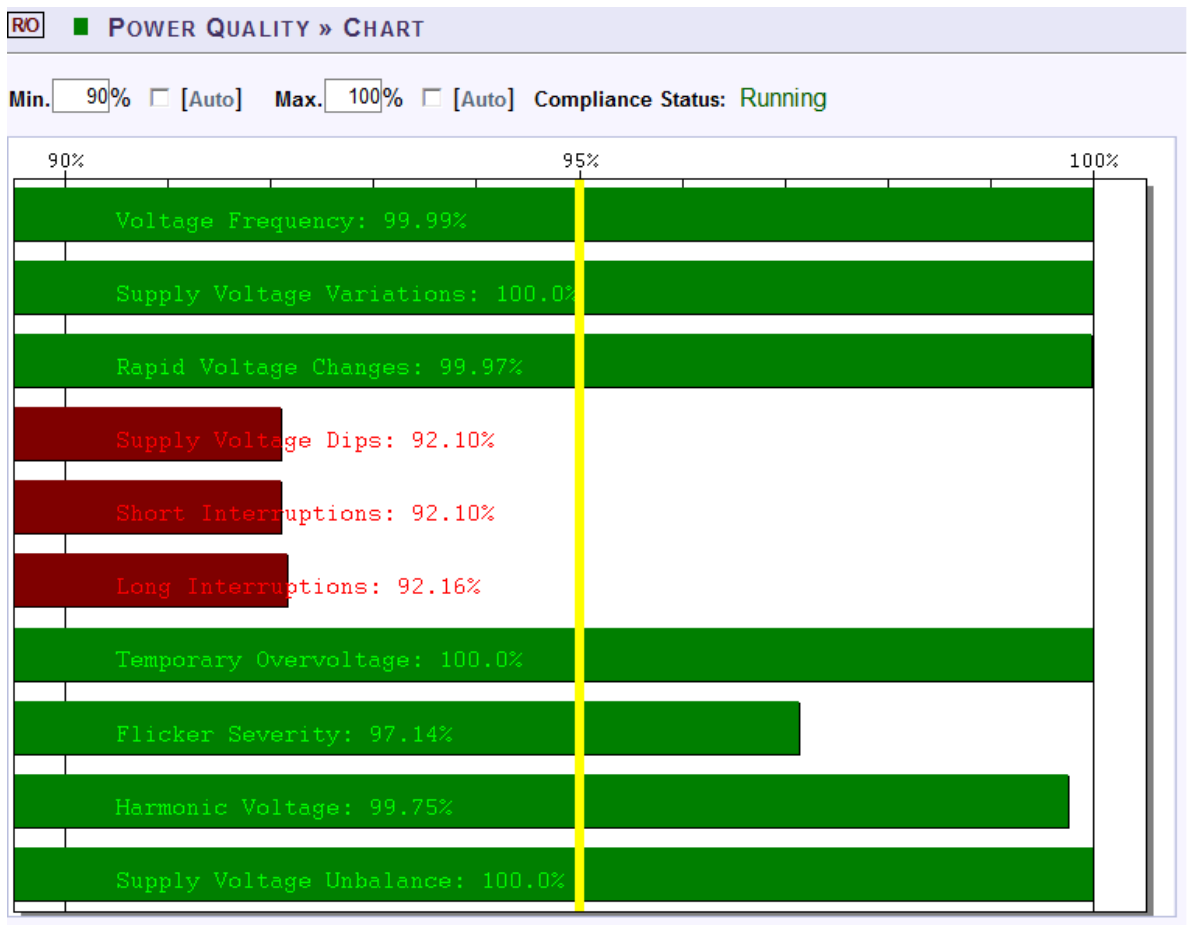

- The minimum and maximum values in the chart may be configured by deselecting **Auto** for each value (Default = 90% Min / 100% Max)

chart options:

As the Compliance Chart is intended to be used only as a chart & regardless that all the options are displayed, only certain options & capabilities are available for the Compliance Chart.

- Right-click on the chart to access the options:

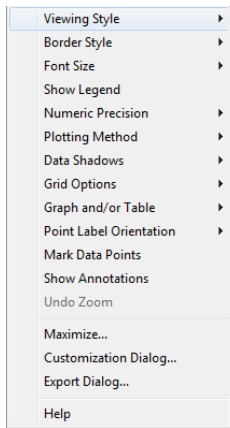

- **Viewing Style:** Different styling options Color / Monochrome (B&W) with/without Symbols / Bitmap etc. By selecting the option you can view on screen the different styles available to you
- **Border Style:** No Border, Thin Line, Shadow / Inset
- **Font Size:** Large / Medium / Small
- **Data Shadows:** Off / Shadow / 3D
- **Export Dialog:** Various Export Options -

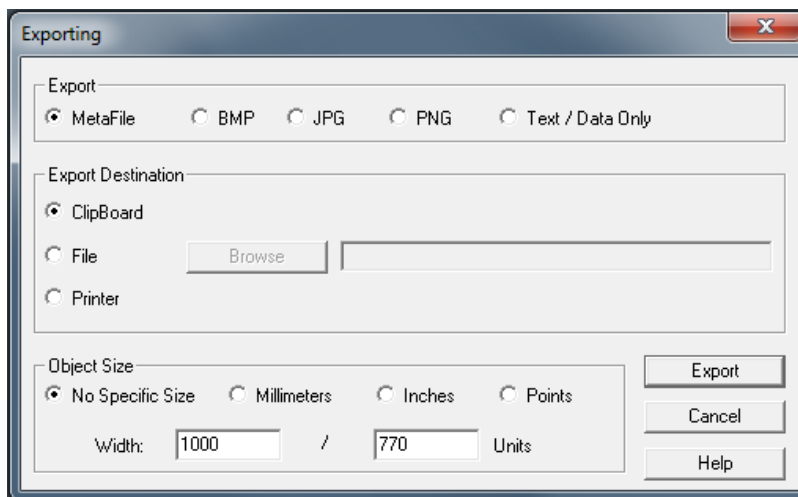

SEE ALSO:

- [About PQ Monitoring](#)
- [Compliance Summary](#)
- [Compliance Info](#)
- [Events](#)
- [PQ Compliance Configuration](#)

Events

The Events window supplies a **Log** that displays Configured PQ Events. Within in the Log you can decide what data you would like to display & produce a report.

OPEN THE EVENTS WINDOW TO PRODUCE A PQ EVENT LOG:

- [Access your Portable BLACKBOX Unit](#) ➔ log on as the **Viewer/Administrator** ➔ under **Power Quality** ➔ open the **Event Tab**:

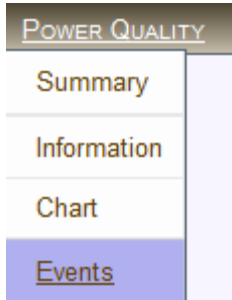

- The **Event Log** window will now open:

RO ■ POWER QUALITY » EVENTS			
Start at <input type="text" value="0"/> Page Size <input type="text" value="15"/> Time <input type="text" value="UTC"/> <input type="button" value="Copy log to clipboard"/>			
Logged Events <input type="button" value="Erase Log"/> <input type="button" value="Refresh Log"/>			
#	Event Timestamp	Code	Detailed Event Data
0	25/12/2011 15:50:09	244	PQ Rapid Voltage Changes: 8.454955[%] (8.447266[dev%] 0.000000 [sec] (Event Begin) Severity:36 Phases:WYE 4 wires:1;2;3)
1	25/12/2011 15:50:09	260	Start Voltage Dropdown: 0.095314[V] (99.951172[dev%] 0.000000[sec] (Event Begin) Severity:0 Phases:WYE 4 wires:1;2;3)
2	25/12/2011 15:46:27	236	PQ Short Voltage Interruptions: 0.084560[V] (99.951172[dev%] 72.973518[sec] Severity:222 Phases:WYE 4 wires:1;2;3)
3	25/12/2011 15:46:27	260	Start Voltage Dropdown: 0.084560[V] (99.951172[dev%] 0.000000[sec] (Event Begin) Severity:0 Phases:WYE 4 wires:1;2;3)
4	25/12/2011 15:45:58	235	PQ Voltage Dips: 0.081562[V] (99.951172[dev%] 19.838251[sec] Severity:255 Phases:WYE 4 wires:1;2;3)
5	25/12/2011 15:45:58	236	PQ Short Voltage Interruptions: 0.081562[V] (99.951172[dev%] 19.788305[sec] Severity:169 Phases:WYE 4 wires:1;2;3)
6	25/12/2011 15:45:58	260	Start Voltage Dropdown: 3.909668[V] (98.291016[dev%] 0.000000[sec] (Event Begin) Severity:0 Phases:WYE 4 wires:1;2;3)
7	25/12/2011 15:45:12	235	PQ Voltage Dips: 0.091911[V] (99.951172[dev%] 14.598695[sec] Severity:255 Phases:WYE 4 wires:1;2;3)
8	25/12/2011 15:45:12	236	PQ Short Voltage Interruptions: 0.091911[V] (99.951172[dev%] 14.558675[sec] Severity:164 Phases:WYE 4 wires:1;2;3)

OPTIONS & FUNCTIONS:

- **Start at:** Specify the event range
- **Page Size:** Number of entries per page
- **Time:** Log entries will be displayed at specific time zone (UTC or Local time)
- **Copy log to clipboard:** Will copy the Event Log over to common Windows applications (Notepad, MS Outlook, Excel & Word). Simply select the command & **Paste** it in one of these applications.
- **Erase Log:** Will clear all the log entries & restart the System log from the time you select this option
- **<<:** Go to previous page
- **Refresh Log:** Refresh your view
- **>>:** Go to the next page

SEE ALSO:

- [About PQ Monitoring](#)
- [Compliance Summary](#)
- [Compliance Info](#)
- [Compliance Chart](#)
- [PQ Compliance Configuration](#)
- [System Log](#)

PQZIP Recording - Principle

The Portable BLACKBOX is able to continuously record & store all the electrical waveforms, all the time, in the case of the G4500 for more than a year, with no gaps in the data. The innovation behind this capability is the PQZIP compression technology. The patented PQZIP enables you to store up to a 1000 times more information than typical formats, allowing for storage of complete & precise data over extended periods of time.

FLOW DIAGRAM:

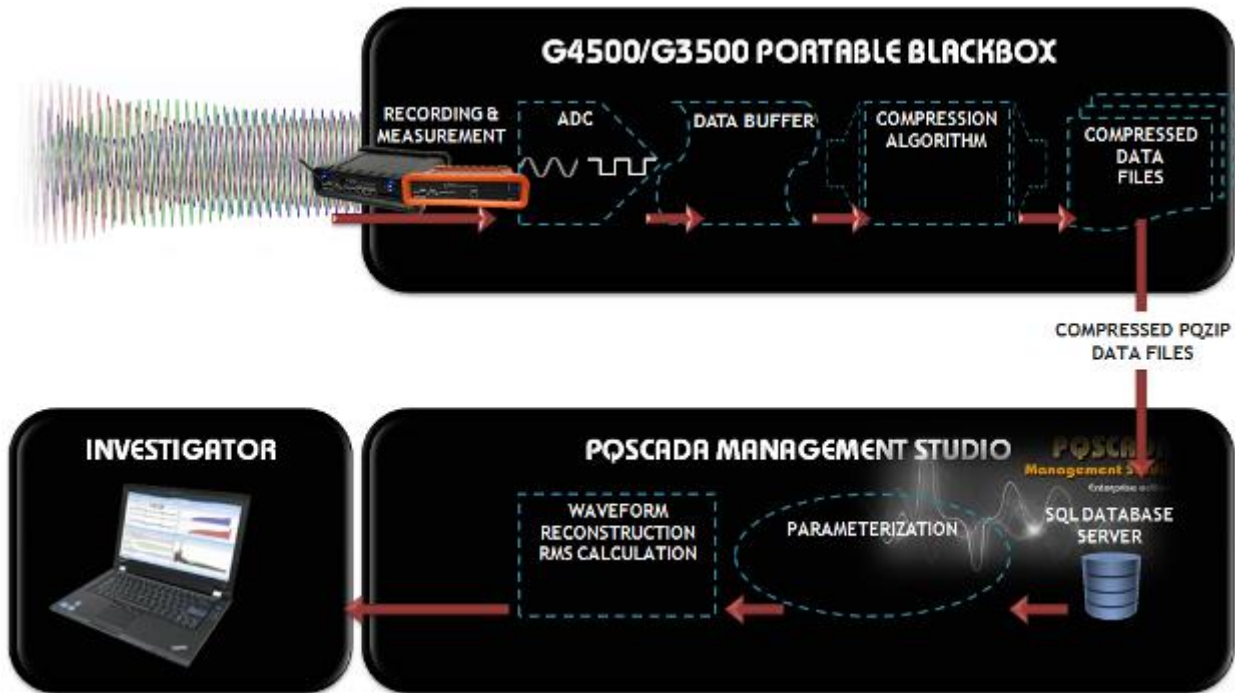

DEFINITIONS:

- **Recording & Measurement:** The waveforms are being sampled at 1024 samples per cycle resolution for voltages and 256 samples per cycle resolution for currents.
- **ADC:** Voltages and currents are being converted & scaled to achieve a maximum resolution using the following Analog to Digital Conversion process.
- **Data Buffer:** The digital waveform data is buffered resulting in 512 spectral components (harmonics) per cycle for voltages and 128 for currents.
- **Compression Algorithm:** Every harmonic component is being analyzed and compressed individually. Zero value components are skipped. No-zero harmonic components are evaluated over time & only changes in a value or angle are processed. Resulting in storage of complete & precise data over extended periods of time.
- **Compressed Data Files:** The compressed harmonic data is being organized in blocks of 5 minutes or more, consisting of concurrent cycles and being stored along with the measured frequency of every cycle and reference time stamps into a PQZIP file residing on the onboard flash memory. The typical compression ratio expected as a ratio between incoming data volume on block 3 and the data being stored is 1000:1.

- **Compressed PQZIP Data File Transferral:** The PQZIP files can be downloaded automatically or manually over a number of communication gateways for further storage and analysis.
- **SQL Database Server:** The resulting data is stored in the SQL database for long term storage. The compressed data is then reorganized and optimized for fast access while in a compressed state.
- **Parameterization:** When required, the data is decompressed, recovering a full spectrum of all the electrical parameters for each cycle, at the associated time stamps.
- **Waveform Reconstruction RMS Calculation:** The spectral data can further be used to reconstruct waveforms for any individual cycle at an extremely high resolution with accurate time and cycle duration. Any possible electrical parameters can be calculated based on the data by retrieving precise accuracy and wave shape.
- **Investigator:** The waveform displayed by the Investigator application is reconstructed based on compressed spectral data of every concurrent network cycle. In addition, virtually any electrical parameter can be calculated based on that data and displayed at any resolution or time span.

SEE ALSO:

- [Default Settings](#)
- [PQZIP Recording](#)
- [Enabling / Disabling PQZIP](#)
- [FIFO](#)
- [Fixed Quality vs Fixed Ratio](#)
- [File Capacity](#)
- [FFT Mode](#)
- [Capture DC](#)
- [Erasing All PQZIP Data](#)

Default Settings

All Portable BLACKBOX Units leave the factory with PQZIP recording being **Disabled (Off)**. The instrument does not start recording until [PQZIP is Enabled](#). When you will Access your unit for the first time, the Summary in Elspec's Web Interface will display the default settings:



SEE ALSO:

- [Principle of Operation](#)
- [PQZIP Recording](#)
- [Enabling / Disabling PQZIP](#)
- [FIFO](#)
- [Fixed Quality vs Fixed Ratio](#)
- [File Capacity](#)
- [FFT Mode](#)
- [Capture DC](#)
- [Erasing All PQZIP Data](#)

PQZIP Configuration - About PQZIP Recording

The window for PQZIP Configuration & Status is located on the same page namely the **PQZIP Recording Window**. In this window you will be able to:

- [Enable / Disable the PQZIP](#)
- [Understand how the disc space is managed with the FIFO concept](#)
- [Configure either Fixed Quality / Fixed Ratio](#)
- [Configure the Time for Compression with File Capacity](#)
- [Set FFT Mode Calculation](#)
- [How to Erase All PQZIP Data](#)

OPEN THE PQZIP RECORDING WINDOW:

- [Access your Portable BLACKBOX Unit's](#) PQZIP Configuration via Elspec's Web Interface
 ➔ log on as the Administrator ➔ select the Configuration Tab
- Under Advanced select the PQZIP Recording Tab:

CONFIGURATION	
Device Setup	Advanced
Device Info	System Log
Time	Custom Events
Voltages & Frequency	PQZIP Recording
Currents	E-mail Alerts
Communication	Reports
Security	Energy Meter
Network	Display Setup
Serial Ports	Firmware Upgrade
PQ Compliance	
Power Compliance	
User Defined Page 1	
User Defined page 2	
User Defined page 3	

- The PQZIP Status & Configuration Window will now open:

ELSPEC G4500 BLACKBOX SITE NAME

MONITORING ENERGY POWER QUALITY MULT-HO CONFIGURATION Logout

RW ■ CONFIGURATION » PQZIP RECORDING No DSP Sync

Apply Changes Refresh Data Erase PQzip Data State: Enable

PQZIP Information		Tolerance (%)	
Compression	99.9999 %	V ₁	0.097656
Start Time	13/07/1975 20:41:36 UTC	V ₂	0.097656
Filename	FF_0B9698_19750726_222931_262_5973_10.PQZip	V ₃	0.097656
Compact Flash information		V _N	0.097656
Free CF Space	24.9 GBytes	I ₁	0.097656
Total CF Space	29.8 GBytes	I ₂	0.097656
		I ₃	0.097656
		I _N	0.097656
		I ₅	AAAAAAA

PQZip Configuration		
PQZip Mode	Quality Thresholds (%)	
Fixed Quality	V 0.1 I 0.1	
File Capacity	FFT Mode	
150 min	V:512 I:128	
Capture V_{DC}	Capture I_{DC/Leak}	Capture V_{Leak}
Disable	Disable	Disable

THE STATUS SECTION:

The Status Section of the PQZIP Recording Window is divided into three sections:

- PQZIP Information:**

PQZIP Information	
Compression	99.939 %
Start Time	25/12/2011 12:14:19 UTC
Filename	FF_0B96A8_20111227_045954_180_9900_3.PQZip

- Compression %:** % Of data compressed for configured period on successful completion of previous compression

- **Start Time:** Time when data compression started (according to configuration)
- **File Name:** Name under which the file for this session will be saved - this is important for future reference
- **Compact Flash Information:**

Compact Flash information	
Free CF Space	23.1 GBytes
Total CF Space	30.1 GBytes

- **Free CF Space:** Free internal memory space of your BLACKBOX unit
- **Total CF Space:** Total memory capacity of your BLACKBOX unit
- **Tolerance %:**

Tolerance (%)	
V ₁	0.0977
V ₂	0.0977
V ₃	0.0977
V _N	0.0977
I ₁	0.0977
I ₂	0.0977
I ₃	0.0977
I _N	0.0977
I ₅	AAAA

The tolerance value is calculated in % to the Nominal Configuration for the specific channel.

THE CONFIGURATION SECTION:

In this section you will be able to configure the PQZIP Recording:

PQZip Configuration		
PQZip Mode Fixed Quality Fixed Ratio	Quality Thresholds (%) V: 0.1 I: 0.1	
File Capacity 5 min 30 min 60 min 90 min 120 min 150 min	FFT Mode V:512 I:128 V:256 I:256	
Capture V_{DC} Disable Enable	Capture I_{DC/Leak} Disable Enable	Capture V_{Leak} Disable Enable

- Leakage Voltage & Current Recording Configuration**

Both voltage & current PQZIP channels recording must be enabled in order to support leakage current channels as illustrated below.

In case the PQZIP recording is enabled while change is applied, it is advised to disable it and then enable it again.

Enable/Disable leakage voltage PQZIP recording

PQZip Configuration		
PQZip Mode	Quality Thresholds (%)	
Fixed Quality ▾	V <input type="text" value="0"/>	I <input type="text" value="0"/>
File Capacity	FFT Mode	
5 min ▾	V:512 I:128 ▾	
Capture V_{DC}	Capture I_{DC/Leak}	Capture V_{Leak}
Disable ▾	Disable ▾	<input type="button" value="Disable"/> <input type="button" value="Enable"/>

Enable/Disable leakage current PQZIP recording

PQZip Configuration		
PQZip Mode	Quality Thresholds (%)	
Fixed Quality ▾	V <input type="text" value="0"/>	I <input type="text" value="0"/>
File Capacity	FFT Mode	
5 min ▾	V:512 I:128 ▾	
Capture V_{DC}	Capture I_{DC/Leak}	Capture V_{Leak}
Disable ▾	<input type="button" value="Disable"/> <input type="button" value="Enable"/>	Disable ▾

NOTE NOTE NOTE

PQSCADA supports leakage PQZIP channels from version 4.3.0.25 and above. Therefore the PQSCADA server must be upgraded as well if this feature is required.

A PQSCADA server running a prior version (not supporting the leakage voltage & current PQZIP channels) that downloads leakage enabled PQZIP files will mark them as 'bad files' and won't process them.

- To apply your changes select [Apply Changes](#)

NOTE NOTE NOTE

- If you are not logged on as the Administrator, you will not be able to change any of these settings & you will receive the following error message in your attempt to do so:

Unprivileged Access

You are not authorized to access this feature. Please re-login with the correct password.

[Click here to re-login.](#)

- Once you have signed on at the Administrator ensure that you select [Apply Changes](#) to actually affect your changes.

SEE ALSO:

- [Principle of Operation](#)
- [Default Settings](#)
- [Enabling / Disabling PQZIP](#)
- [FIFO](#)
- [Fixed Quality vs. Fixed Ratio](#)
- [File Capacity](#)
- [FFT Mode](#)
- [Capture DC](#)
- [Erasing All PQZIP Data](#)

Enabling / Disabling PQZIP

As mentioned previously, your Portable BLACKBOX arrives from the factory with PQZIP recording Disabled. By initiating Enable will prompt your Portable BLACKBOX to commence recording & Disable simply means that your device cease recording.

HOW TO ENABLE & DISABLE PQZIP RECORDING

- Access your Portable BLACKBOX Unit's PQZIP Configuration via the [PQZIP Recording Tab](#)
- In the **State** drop-down selection select **Enable**:

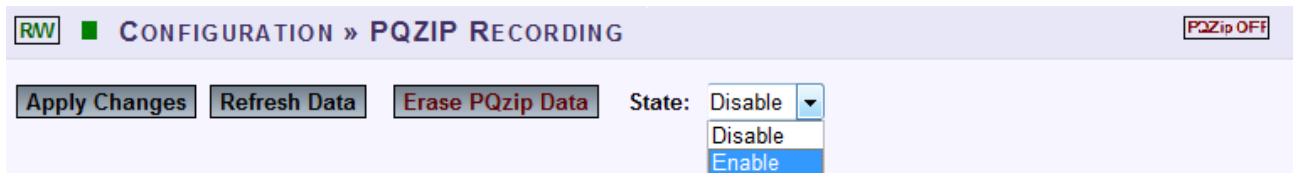

- To apply your changes select [Apply Changes](#)
- The following warning may appear if some parameter readings are inconsistent with the configuration. In this case make sure all parameters are correct before enabling the PQZIP:

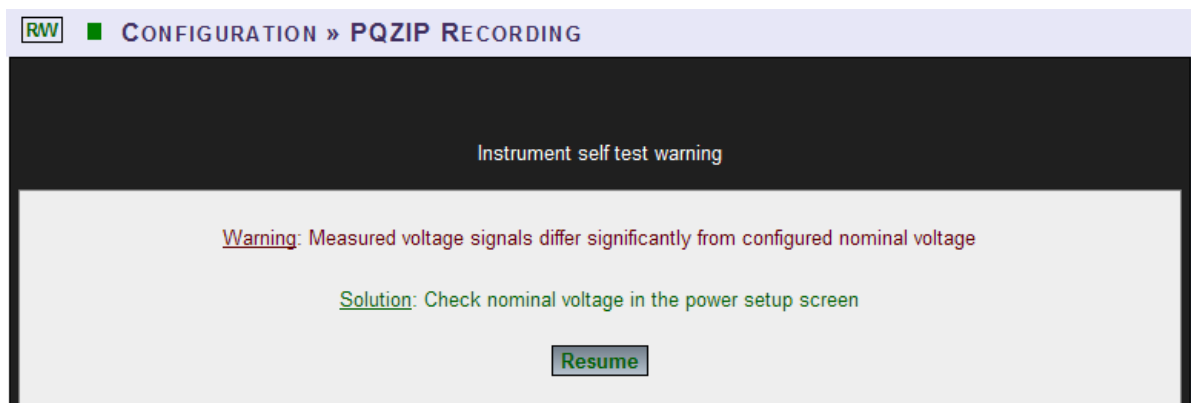

- Confirm by selecting [Resume](#) & the following success message will appear:

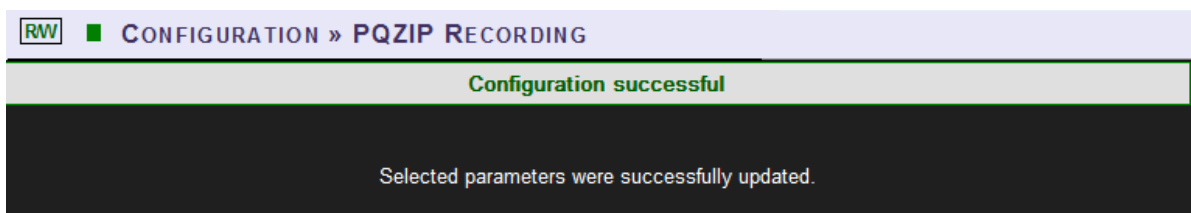

- To view your changes (refresh your current view) select [Refresh Data](#)

NOTE NOTE NOTE

- If you are not logged on as the Administrator, you will not be able to change any of these settings & you will receive the following error message in your attempt to do so:

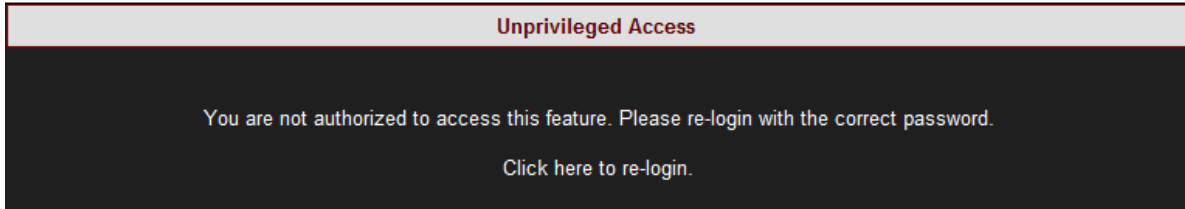

- Once you have signed on at the Administrator ensure that you select **Apply Changes** to actually affect your changes.
- Once you have enabled the PQZIP recording, the PQZIP OFF Icon will no longer appear on the right-hand side on this & any other screen:



SEE ALSO:

- [Principle of Operation](#)
- [Default Settings](#)
- [PQZIP Recording](#)
- [FIFO](#)
- [Fixed Quality vs Fixed Ratio](#)
- [File Capacity](#)
- [FFT Mode](#)
- [Capture DC](#)
- [Erasing All PQZIP Data](#)

FIFO

PQZIP files are maintained on the BLACKBOX'S local Flash Memory based on the FIFO (First In First Out) concept. As the BLACKBOX continuously records & measures all electrical information, & therefore the file storage operation never stops. As such, when the on-board memory becomes full, the oldest files are deleted automatically to free required space for the newest data. However, the [PQZIP compression](#) itself allows for the storage of a 1000 times more information than typical formats & in addition the Portable BLACKBOX Device series is equipped with substantial memory capacity (G4500 32GB; G3500 256MB). This dramatically increases storage capacity & the G4500 is capable to record & store all electrical waveforms, all the time, for more than a year.

In addition by simply downloading the files from the Incoming Folder by using PQSCADA / FTP, data can be stored outside the BLACKBOX's on-board memory as much as your Network Server's can capacitate the files.

SEE ALSO:

- [Principle of Operation](#)
- [Default Settings](#)
- [PQZIP Recording](#)
- [Enabling / Disabling PQZIP](#)
- [Fixed Quality vs Fixed Ratio](#)
- [File Capacity](#)
- [FFT Mode](#)
- [Capture DC](#)
- [Erasing All PQZIP Data](#)

Fixed Quality vs. Fixed Ratio

The most important parameter defining the actual compression ratio, (which determines the amount of storage required and maximum time continuous data can be stored) is a PQZIP Threshold value or **Tolerance** as it referred on the WEB page. The Tolerance defines what change in an individual harmonic would be defined as significant enough to be stored and reproduced afterwards.

The tolerance value is calculated in percentage to the full scale or nominal reading for the specific channel. It is assumed that changes within 0.1% of nominal would have no importance in further power quality investigation, and the values within that range are averaged to store the representative value only. The basic and factory default tolerance value is normally defined as 0.1%. However, on some sites/networks that value can still be considered too low, for example, a highly fluctuating load or voltage lines. It is most likely that a user would prefer increasing a tolerance value for currents or voltages or even both in order to achieve better compression ratios on highly polluted network locations.

Configuring fixed ratio:

The Portable BLACKBOX provides the possibility of automatic adjustment of the actual tolerance value presuming a compression ratio defined as amount of data being stored per month. This option is called **Fixed Ratio**. When selected, the user is requested to define the amount of data to be stored per month (**Monthly Ratio**) in **MB**. Usually, slight voltage spectral changes have higher importance than current changes. Therefore, the amount of data which could be stored for voltages may be determined as greater than for currents. The **V/I Relation** parameter defines the relationship between the data (a part of the Monthly Ratio) reserved for voltage. If the voltage portion is larger than currents, the system will define a tighter tolerance for voltages than for currents.

- Access your Portable BLACKBOX Unit's PQZIP Configuration via the [PQZIP Recording Tab](#)
- In the **PQZIP Configuration** section, go to the **PQZIP Mode** & from the drop-down selection select **Fixed Ratio** followed by [Apply Changes](#). The **PQZIP Configuration** window will now open:

PQZip Configuration		
PQZip Mode	Monthly Ratio	V/I Relation (%)
Fixed Ratio ▾ Fixed Quality Fixed Ratio	700 MB	66 ⇅ V ————— I

- Define the amount of data stored per month, by entering the **MB Value** in the **Monthly Ratio** text box
- Set the appropriate **V/I Relation** value with the ⇅
- To apply your changes select [Apply Changes](#)

- You will receive the following success message:

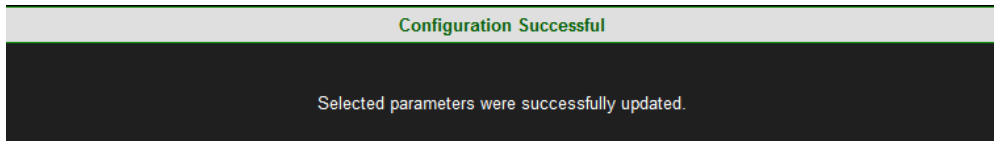

- To view your changes (refresh your current view) select [Refresh Data](#)

CONFIGURING FIXED QUALITY:

With the **Fixed Quality** option you are able to define & fix the tolerance values for both voltages and currents as per your preferred value. This means that data will be stored at the same tolerance/quality at all times.

- [Access your Portable BLACKBOX Unit's](#) PQZIP Configuration via the [PQZIP Recording Tab](#)
- In the **PQZIP Configuration** section, go to the **PQZIP Mode** & from the drop-down selection select **Fixed Quality**:

PQZip Configuration	
PQZip Mode	Quality Thresholds (%)
Fixed Quality ▾ Fixed Quality Fixed Ratio	V <input type="text" value="0.1"/> I <input type="text" value="0.1"/>

- Define the fixed tolerance values for both **Voltage** & **Current** by entering the **Threshold %** in the respective **Quality Threshold %** text box
- To apply your changes select [Apply Changes](#)
- You will receive the following success message:

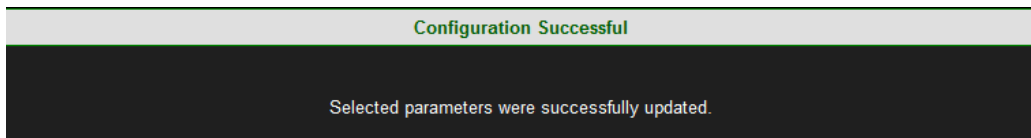

- To view your changes (refresh your current view) select [Refresh Data](#)

NOTE NOTE NOTE

- Setting thresholds to 0 creates large amounts of data that can fill up all available disk space. This should only be done when investigating localized faults for brief periods of time.
- If you are not logged on as the Administrator, you will not be able to change any of these settings & you will receive the following error message in your attempt to do so:

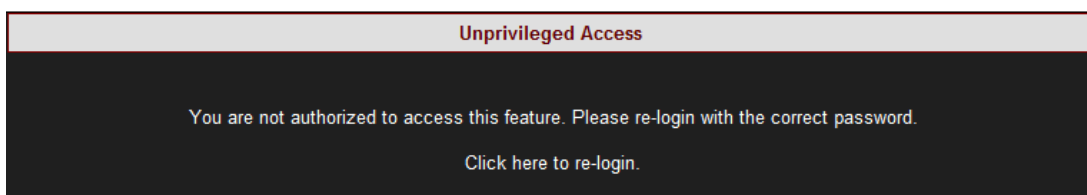

- Once you have signed on at the Administrator ensure that you select [Apply Changes](#) to actually affect your changes.

SEE ALSO:

- [Principle of Operation](#)
- [Default Settings](#)
- [PQZIP Recording](#)
- [Enabling / Disabling PQZIP](#)
- [FIFO](#)
- [File Capacity](#)
- [FFT Mode](#)
- [Capture DC](#)
- [Erasing All PQZIP Data](#)

File Capacity

The File Capacity parameter is used to define the maximum time each PQZIP file will take to compress. The file can be downloaded and data can be analyzed only when the file is closed, so if you expect to monitor the data in the Investigator application shortly after the data is being collected, you should choose low time durations. For all other cases, longer durations are recommended so compression ratios can be slightly improved.

CONFIGURING THE FILE CAPACITY PARAMETER:

- Access your Portable BLACKBOX Unit's PQZIP Configuration via the [PQZIP Recording Tab](#)
- In the **PQZIP Configuration** section, go to the **File Capacity** & from the drop-down selection select the applicable **Time Period**:

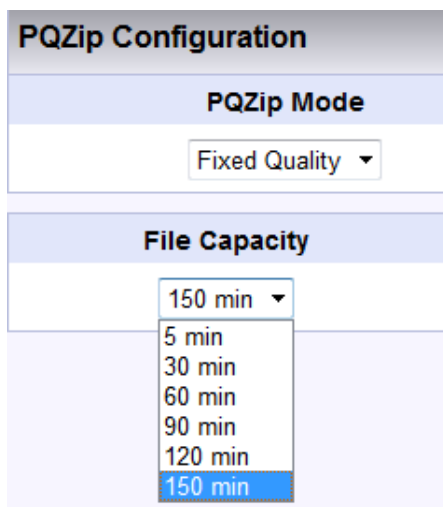

- To apply your changes select [Apply Changes](#)
- You will receive the following success message:

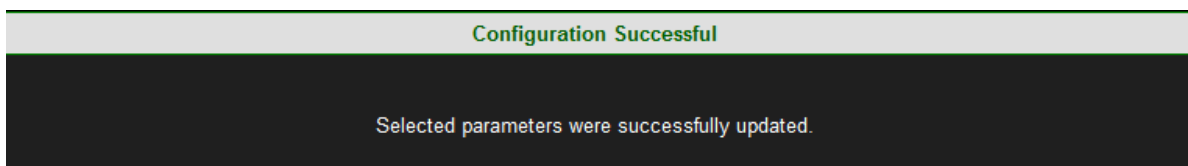

- To view your changes (refresh your current view) select [Refresh Data](#)

Note Note Note

- If you are not logged on as the Administrator, you will not be able to change any of these settings & you will receive the following error message in your attempt to do so:

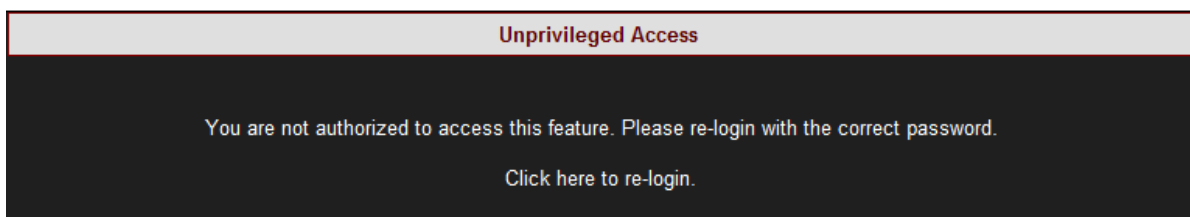

- Once you have signed on at the Administrator ensure that you select [Apply Changes](#) to actually affect your changes.

SEE ALSO:

- [Principle of Operation](#)
- [Default Settings](#)
- [PQZIP Recording](#)
- [Enabling / Disabling PQZIP](#)
- [FIFO](#)
- [Fixed Quality vs Fixed Ratio](#)
- [FFT Mode](#)
- [Capture DC](#)
- [Erasing All PQZIP Data](#)

FFT Mode

The FFT Mode is a built-in capability applicable only to the G4500 BLACKBOX. The sampling rate for the G4500 is 1,024 samples per cycle for Voltage & 256 samples per cycle for Current. Or alternatively, the sampling rate may be switched to 512 samples per cycle for Voltage & 512 samples per cycle for Current.

CONFIGURING THE FILE CAPACITY PARAMETER:

- Access your Portable BLACKBOX Unit's PQZIP Configuration via the [PQZIP Recording Tab](#)
- In the **PQZIP Configuration** section, go to the **FFT Mode** & from the drop-down selection select the applicable **Ratio**:

PQZip Configuration		
PQZip Mode	Quality Thresholds (%)	
Fixed Quality ▾	V 0.1	I 0.1
File Capacity	Record Mode	FFT Mode
150 min ▾	FULL ▾	V:512 I:128 ▾
		V:512 I:128
		V:256 I:256

Select:

- File Capacity:** Used for setting compression at every: 5min; 30min; 60min; 90min; 120min & 150min (Increased frequency will produce more files - therefore set the frequency according to your network capacity)
- FFT Mode:** The sampling rate setting reflected from the drop down selection is half of the actual sampling rate - V:512 I:128 & V:256 I:256. To set your sampling rate select:
 - V:512 I:128** for actual 1,024 (Voltage) & 256 (Current) samples per cycle
 - V:256 I:256** for actual 512 (Voltage) & 512 (Current) samples per cycle
- To apply your changes select [Apply Changes](#)
- You will receive the following success message:

Configuration Successful

Selected parameters were successfully updated.

- To view your changes (refresh your current view) select [Refresh Data](#)

NOTE NOTE NOTE

- If you are not logged on as the Administrator, you will not be able to change any of these settings & you will receive the following error message in your attempt to do so:

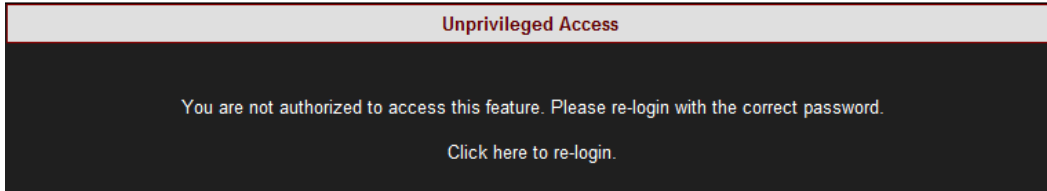

- Once you have signed on at the Administrator ensure that you select **Apply Changes** to actually affect your changes.

SEE ALSO:

- [Principle of Operation](#)
- [Default Settings](#)
- [PQZIP Recording](#)
- [Enabling / Disabling PQZIP](#)
- [FIFO](#)
- [Fixed Quality vs Fixed Ratio](#)
- [File Capacity](#)
- [Capture DC](#)
- [Erasing All PQZIP Data](#)

Capture DC Measurements

This feature enables you to record / stop the recording for Direct Current at will, without having to **disconnect** your [DC Voltage & Current Probes](#). The factory settings is automatically **Disabled** & you will need to **Enable** the recording as per the procedure below:

ENABLING DC RECORDINGS:

- Access your Portable BLACKBOX Unit's PQZIP Configuration via the [PQZIP Recording Tab](#)
- In the **PQZIP Configuration** section, go to the **Capture V/I_{DC}** & from the drop-down selection select either **Enable / Disable**:

Capture V _{DC}	Capture I _{DC}
<div style="border: 1px solid #ccc; padding: 2px;"> Disable ▾ Disable Enable </div>	<div style="border: 1px solid #ccc; padding: 2px;"> Disable ▾ Disable Enable </div>

- To apply your changes select **Apply Changes**
- You will receive the following success message:

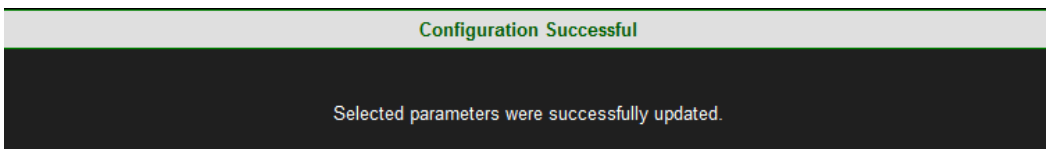

- To view your changes (refresh your current view) select **Refresh Data**

NOTE NOTE NOTE

- If you are not logged on as the Administrator, you will not be able to change any of these settings & you will receive the following error message in your attempt to do so:

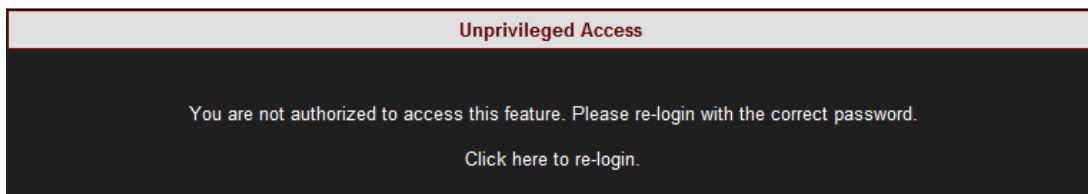

- Once you have signed on at the Administrator ensure that you select **Apply Changes** to actually affect your changes.

SEE ALSO:

- [Principle of Operation](#)
- [Default Settings](#)
- [PQZIP Recording](#)
- [Enabling / Disabling PQZIP](#)
- [FIFO](#)
- [Fixed Quality vs Fixed Ratio](#)
- [File Capacity](#)
- [FFT Mode](#)
- [Erasing All PQZIP Data](#)



Erase All PQZIP Data

This function will allow you to delete all the PQZIP files from your Portable BLACKBOX's internal Compact Flash Memory. **Prior to proceeding ensure that you've downloaded all the PQZIP files you needed from your G4500/G3500 unit, as the procedure cannot be reversed.**

ERASE PQZIP DATA:

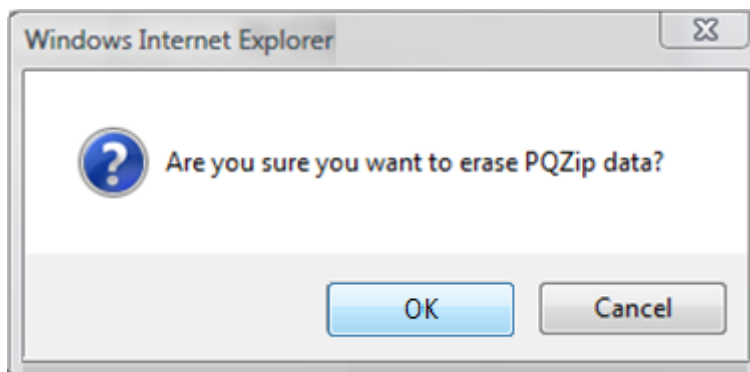
- Access your Portable BLACKBOX Unit's PQZIP Configuration via the [PQZIP Recording Tab](#)
- Select **Erase PQzip Data** & you will receive the following message:

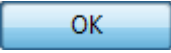

- To apply your changes select  ➔ 
- You will receive the following success message:

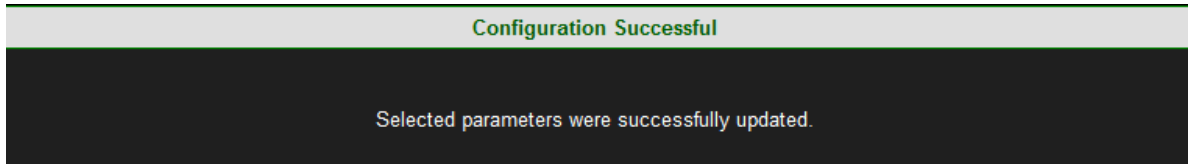

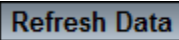
- To view your changes (refresh your current view) select 

Note Note Note

- If you are not logged on as the Administrator, you will not be able to change any of these settings & you will receive the following error message in your attempt to do so:

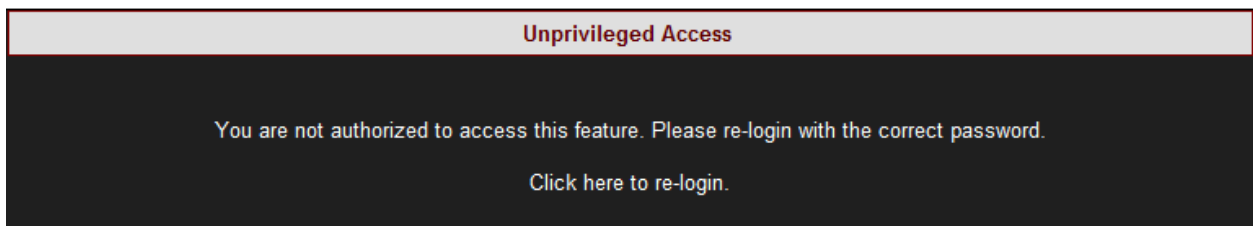

- Once you have signed on at the Administrator ensure that you select  to actually affect your changes.

SEE ALSO:

- [Principle of Operation](#)
- [Default Settings](#)
- [PQZIP Recording](#)
- [Enabling / Disabling PQZIP](#)
- [FIFO](#)
- [Fixed Quality vs Fixed Ratio](#)
- [File Capacity](#)
- [FFT Mode](#)
- [Capture DC](#)

Energy - About

Energy is defined as power consumed over time. In electrical distribution systems, the unit of time is one hour for all energy measurements and the kWh is the basis for payment for buying and selling energy.

The Energy section focuses on the flow of energy or power both within a system (active, reactive) as well as the flow of power to and from the system to the grid (delivered or received). In this section you will be able to:

- [Review the overall Consumption & Demand of your Electrical System](#)
- [View a Detailed Breakdown of Energy Flow Components](#)
[Review Statistical Information Regarding Measurement Status](#)

Consumption & Demand

Energy is produced and consumed within an electrical distribution system. Some sites produce energy for the grid (Received Energy), others consume energy from the grid (Delivered Energy), and still others both consume and produce energy for/from the grid. The Net Consumption is the difference between energy that is used and produced. Therefore, a negative value for Net Consumption indicates that the site is producing more than it is consuming, or a received net consumption.

The Consumption & Demand window is a quick look at some of the key components of the [Detailed Information](#) window. Here you find a cross-sectional summary view of the amount and makeup (**Active or Reactive**) of the **Net Energy (Received - Delivered)** produced/consumed by a site.

A Demand is an arbitrary measurement of average power usage per configured unit time. A demand is measured in units of power even though a time element does exist, while Peak Demand is the highest demand calculated since the last demand reset. Refer to Energy Meter in the **Advanced Settings** section to reset the demand of your energy meter.

Access general information regarding consumption & demand:

- [Access your Portable BLACKBOX Unit](#) → log on as the **Viewer/Administrator** → under **Energy** → open the **Consumption & Demand** Tab:

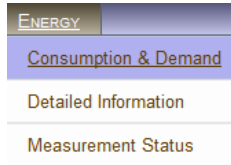

- The **Consumption & Demand** window will now open:

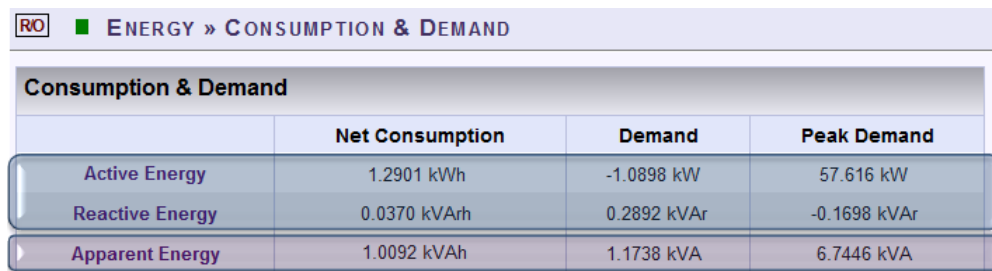

	Net Consumption	Demand	Peak Demand
Active Energy	1.2901 kWh	-1.0898 kW	57.616 kW
Reactive Energy	0.0370 kVArh	0.2892 kVAr	-0.1698 kVAr
Apparent Energy	1.0092 kVAh	1.1738 kVA	6.7446 kVA

Included in this window are commonly used terms in describing energy flow within a system:

- **Active Energy (Real Energy):** The portion of power flow that, averaged over a complete cycle of the AC waveform, results in the net transfer of energy in one direction expressed as kWh
- **Reactive /Volt Amperes Reactive Energy (kVArh):** Energy that flows back and forth with no actual power flow. Reactive power flow transfers no net energy to the load and is sometimes referred to as Wattless power
- **Apparent:** The combination of active and reactive energy (kVAh)

The corresponding Blue & Pink sections will be displayed in more detail in the [Detailed Information](#) window.

SEE ALSO:

- [About Energy](#)
- [Measurement Status](#)

Detailed Information

For a detailed breakdown of energy flow components, the **Detailed Information** window presents all the **Active & Reactive** values individually for both produced and consumed (**Received or Delivered**) energy. In addition the **Net Difference Received - Delivered (Net Energy Received)** as well as the **Net Difference Delivered - Received (Net Energy Generated)** computations are included within this window. The **Total Energy Computation Section** contains the combined figure for **Received & Delivered Energy**.

As previously stated, the **Consumption & Demand (Summary)** window is extracted from the Details window. The corresponding values are indicated in Blue & Green in the Detailed Information Window below.

Access general information regarding consumption & demand:

- Access your Portable BLACKBOX Unit → log on as the Viewer/Administrator → under Energy → open the Detailed Information Tab:

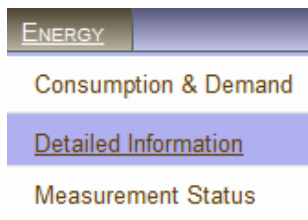

- The **Detailed Information** window on energy flow components will now open:

Consumption & Demand				
	Net Consumption	Demand	Peak Demand	
Active Energy	1.2901 kWh	-1.0898 kW	57.616 kW	
Reactive Energy	0.0370 kVAh	0.2892 kVA	0.1698 kVA	
Apparent Energy	1.0092 kVAh	1.1738 kVA	6.7446 kVA	

ENERGY » DETAILED INFORMATION				
Received Energy				
	Current Period	Total Consumption	Demand	Peak Demand
Active Energy	0.0000 kWh	1.7110 kWh	0.0000 kW	61.356 kW
Reactive Energy	0.0010 kVAh	0.0862 kVAh	0.2892 kVA	0.2956 kVA
Delivered Energy				
	Current Period	Total Consumption	Demand	Peak Demand
Active Energy	0.0037 kWh	0.4208 kWh	1.0898 kW	3.7393 kW
Reactive Energy	0.0000 kVAh	0.0492 kVAh	0.0000 kVA	0.4654 kVA
Net Energy (Received-Delivered)				
	Current Period	Total Consumption	Demand	Peak Demand
Active Energy	-0.0037 kWh	1.2901 kWh	-1.0898 kW	57.616 kW
Reactive Energy	0.0010 kVAh	0.0370 kVAh	0.2892 kVA	-0.1698 kVA
Net Generated Energy (Delivered-Received)				
	Current Period	Total Consumption	Demand	Peak Demand
Active Energy	0.0037 kWh	-1.2901 kWh	1.0898 kW	-57.616 kW
Reactive Energy	-0.0010 kVAh	-0.0370 kVAh	-0.2892 kVA	0.1698 kVA
Total Energy (Received+Delivered)				
	Current Period	Total Consumption	Demand	Peak Demand
Active Energy	0.0037 kWh	2.1318 kWh	1.0898 kW	65.095 kW
Reactive Energy	0.0010 kVAh	0.1353 kVAh	0.2892 kVA	0.7609 kVA
Apparent Energy	0.0040 kVAh	1.0092 kVAh	1.1738 kVA	6.7446 kVA

SEE ALSO:

- [About Energy](#)
- [Measurement Status](#)

Measurement Status

The Measurement Status window provides additional statistical information & necessary context on energy. The parameters & counters on this window are in actual fact configured in **Energy Meter** in the **Advanced Settings Section**, which is directly accessible by selecting the **Configure energy & Demand** button.

Access the measurement status window:

- [Access your Portable BLACKBOX Unit](#) → log on as the **Viewer/Administrator** → under **Energy** → open the **Measurement Status Tab**:

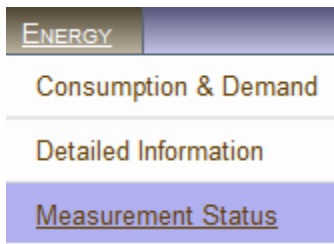

- The **Measurement Status** window will now open:

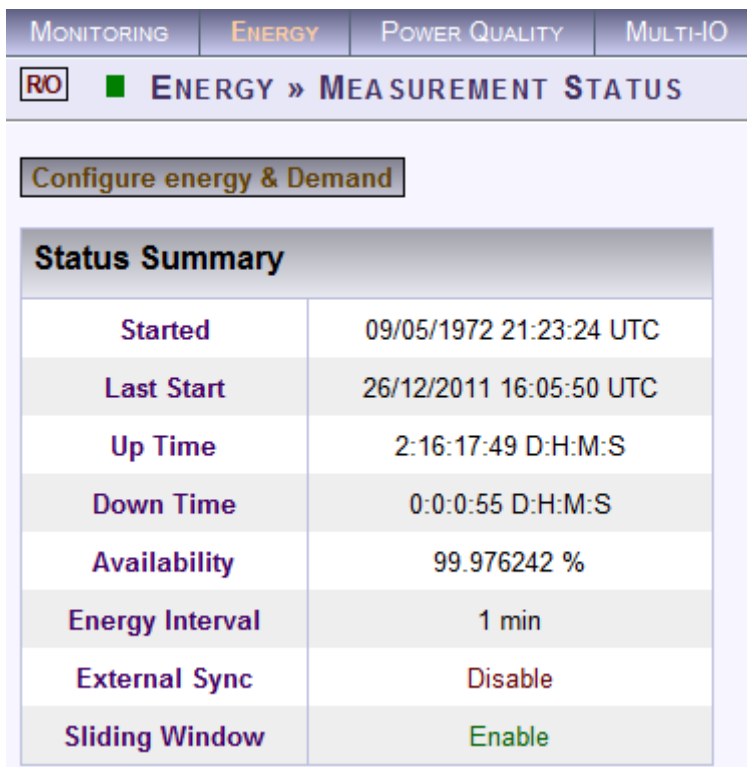

Status Summary	
Started	09/05/1972 21:23:24 UTC
Last Start	26/12/2011 16:05:50 UTC
Up Time	2:16:17:49 D:H:M:S
Down Time	0:0:0:55 D:H:M:S
Availability	99.976242 %
Energy Interval	1 min
External Sync	Disable
Sliding Window	Enable

Included in this window are the following terms:

- **Started:** This is the date and time stamp from the last energy reset
- **Last Start:** This is the date and time stamp for the last metering reset - Total Consumption is Reset
- **Up Time:** The total cumulative time the mechanism has been operational during the current period (since last start)

- **Down Time:** The total cumulative time the mechanism has not been operational during the current period
- **Availability:** The percentage of time the system has been operational - this is important because if this time exceeds a certain threshold, the data may not be considered reliable
- **Energy (Metering) Interval:** The energy interval is the size of the window used in computing demand (e.g. 1 minute)
- **External Sync:** This function is currently fixed in disable mode
- **Sliding Window (Accessed by selecting Configure energy & Demand in Energy Meter:** Information regarding the demand averaging system in use:

SLIDING WINDOW ENABLED:

The energy is calculated using a sliding window. The figure below illustrates the time increment as 1 second:

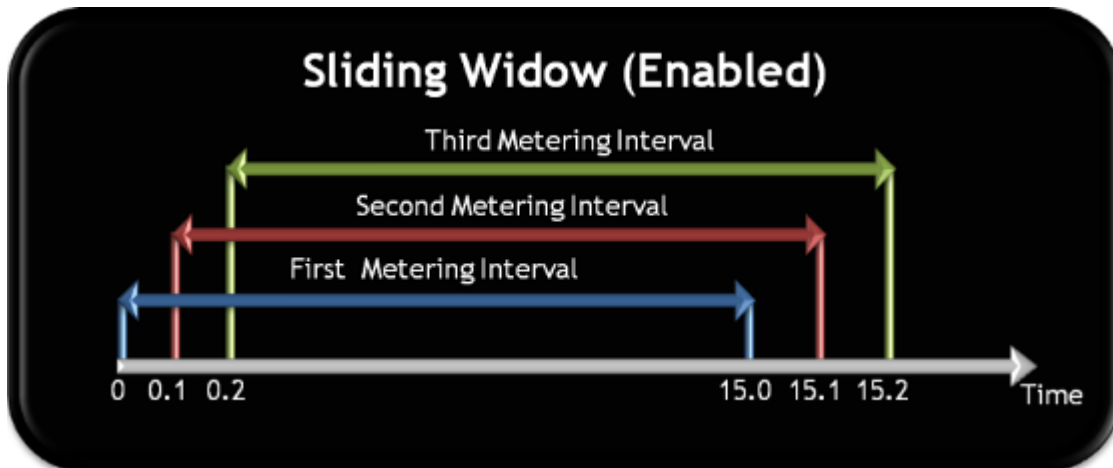

SLIDING WINDOW DISABLED:

The energy is calculated using fixed interval for each meter - illustration:

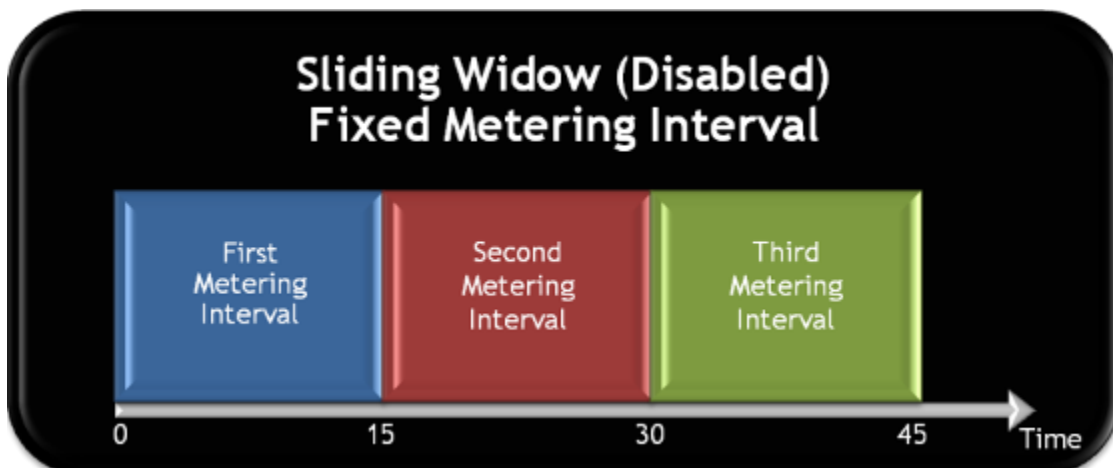

SEE ALSO:

- [About Energy](#)
- [Consumption & Demand](#)
- [Detailed Info](#)

Instrument Settings - About

After you successfully [Installed](#) your device, you will need to configure your Portable Power Quality Analyzer itself in the BLACKBOX's Web Interface. The procedure will demonstrate how to:

- [Setup the Device](#)
- [Establish Communication](#)
- [Configure the PQ Settings](#)

Device Configurations - Overview Device Setup

Configuration of your G4500/G3500 device itself occurs in BLACKBOX's Web Interface on successful [Connection to the Device](#).

- Access your device via Elspec's Search Utility through the **Web** (Identifiable either by the Serial Number / indicated in green as a New Device):

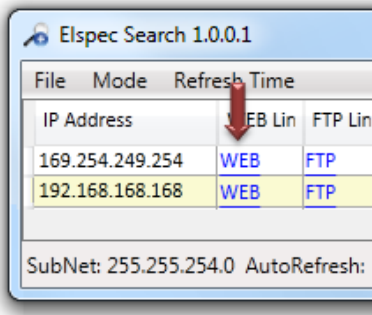

File	Mode	Refresh Time
IP Address	WEB Lin	FTP Lin
169.254.249.254	WEB	FTP
192.168.168.168	WEB	FTP

SubNet: 255.255.254.0 AutoRefresh:

- Select the **Web** link for your device, Elspec's Web Interface will now open:



- In order to view the different languages in the Web Interface, you will need to upload the language feature from [Elspec's Website](#) when installing your new Firmware. Once uploaded, simply select the applicable interface language from the drop-down list:



- The supported languages are:

- English (Default)
- Chinese
- Czech
- German
- French
- Russian
- Spanish

(For other languages - please contact your local Elspec distributor)

- The Password field defines user level/privileges. The user levels are **Viewer / Administrator** (See Security Settings). The default password including privileges for each level are:
 - Viewer is **123** (Read only, can choose interface language only, no operations related changes are allowed)
 - Administrator is **12345** (Administration, setup & full control)
- By selecting the **Configuration Tab** & within the **Device Setup** section you'll be able to:
 - [Complete the Device Info](#)
 - [Set the Time Settings](#)
 - [Configure the Voltage & Frequency](#)
 - [Configure the Current Probes](#)

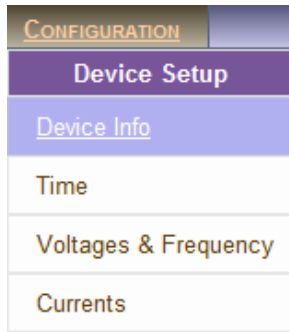

NOTE NOTE NOTE

- The Website is optimized to work with Internet Explorer 7, 8 or 9 in “Compatibility View”. Ensure that the Internet Explorer is running in **Compatibility View**:



Other web browser applications can limit some functionality and/or show an incorrect layout.

- For local networking the browser should be configured as working without a proxy server. Refer to Disable Proxy Server in Internet Explorer.
- The passwords above are factory default values. You are advised to modify Admin password if extended security measures are required (See Security Settings).
- If you are not logged on as the [Administrator](#), you will not be able to change any of these settings & you will receive the following error message in your attempt to do so:

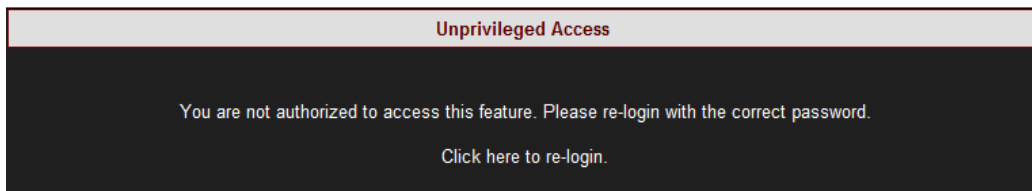

Device Info - Unit Configuration

The purpose of this section is view, understand & configure additional functions for your device itself, after you have completed the initial [Unit Configuration](#).

ACCESS THE DEVICE INFO PAGE:

- [Access](#) your BLACKBOX Portable via **Elspec’s Web Interface** ➡ log on as the **Administrator**
 ➡ select the **Configuration Tab**
- Under **Device Setup** select the **Device Info Tab**:

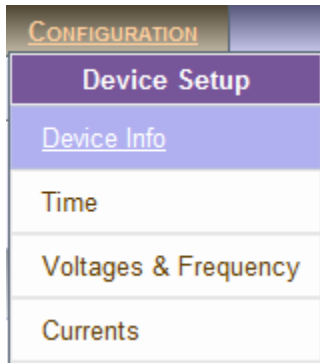

- Within this window you will be able to:
 - Access/Change your original Unit Configurations
 - [View Hardware & Software Information for your G4500/G3500](#)
 - [View all the Details Regarding Power System](#)
 - [Enable/Disable the PoE Output](#)
 - [View/Configure Alarms other System Indications](#)

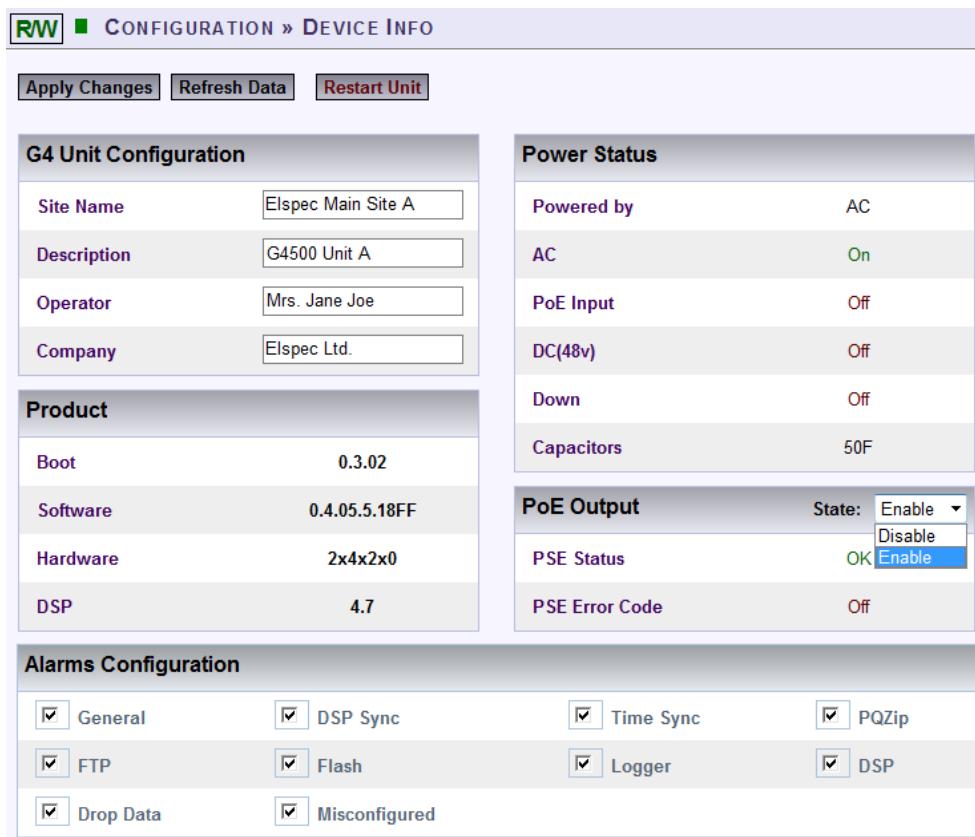

CONFIGURE YOUR Portable Blackbox UNIT:

- After you have opened the **Device Info Page**, in the **G4 Unit Configuration** Section complete:
 - **Site Name:** Enables the user to include a description of the site where the device is installed. This site description also appears in the Elspec's Search utility under Unit Description when searching for devices
 - **Description:** An additional text field for you to use optionally as you see fit

- **Operator:** A text field for inputting the operator/technician's name
- **Company:** A text field for inputting company's name

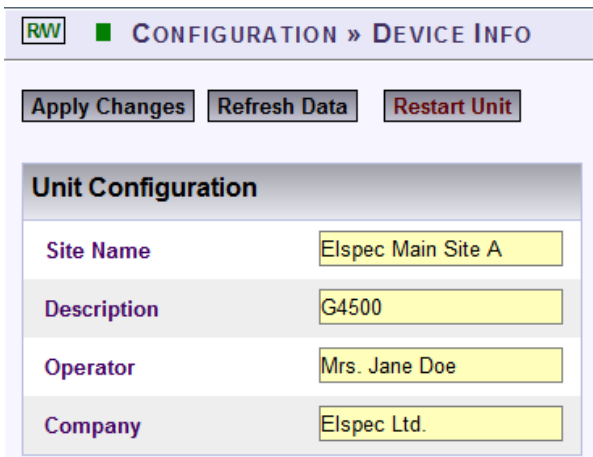

- To apply your changes select **Apply Changes**
- To view your changes & ensure your changes took into affect (refresh your current view) select **Refresh Data**
- To enforce your changes to your G4K unit select **Restart Unit**

NOTE NOTE NOTE

- If you are not logged on as the Administrator, you will not be able to change any of these settings & you will receive the following error message in your attempt to do so:

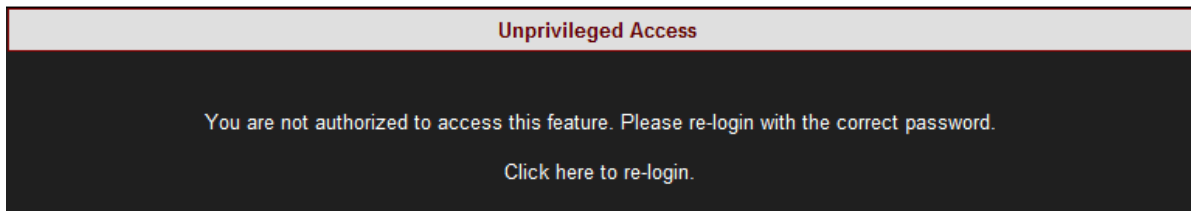

- Once you have signed on as the [Administrator](#), ensure that you select **Apply Changes** to actually affect your changes.

- Go on to the next step [View Product Settings](#)

SEE ALSO:

- [About Instrument Configurations](#)
- [Unit Configuration](#)
- [Product Info](#)
- [Power Status](#)
- [PoE Output](#)
- [Alarms & Other Indications](#)

Product Info

The Product section specifies information regarding the BLACKBOX System Attributes (Software, Hardware):

Product	
Boot	0.3.02
Software	0.4.05.5.18FF
Hardware	2x4x2x0
DSP	4.7

The fields specify the following internal HW and SW Versions:

- **Boot:** Displays the Boot Loader application version. The Boot Loader application is a small separated part of the BLACKBOX Firmware. The Boot is stored on a secured sector in the internal flash memory chip & is used for the HW initialization for loading Firmware upgrades and for further execution of the G4500/G3500's Firmware. The Boot executes either Bank A or Bank B Firmware. See Firmware Upgrade
- **Software:** Displays the BLACKBOX Firmware Version is in use. See Firmware Upgrade
- **Hardware:** Displays the BLACKBOX Hardware Version of the BLACKBOX Modules
- **DSP:** Displays the BLACKBOX DSP Version in use. The G4500/G3500 is equipped with a dedicated **DSP (Digital Signal Processing) Module** for high speed calculations. This field defines the Firmware Version of the code being executed on this DSP.

SEE ALSO:

- [About Instrument Configurations](#)
- [Unit Configuration](#)
- [Power Status](#)
- [PoE Output](#)
- [Alarms & Other Indications](#)

Power Status

Power Status	
Powered by	AC
AC	On
PoE Input	Off
DC(48v)	Off
Down	Off
Capacitors	50F

In this section you can view all the Power Status:

- **Powered by:** Informs the user as to the type of power currently supplying the instrument
- **AC:** AC status (On/Off)
- **PoE Input:** Status of the PoE on the LAN1 port; an alternate power input for the instrument
- **DC (48v):** Status of the [DC Power Supply Input](#)
- **Down:** Should this flag indicate "On" it means that your Portable BLACKBOX has no power supply & is on ride through power supplied by the internal battery
- **Capacitors:** Indicates the size of the Super Capacitor supplying the ride through power

SEE ALSO:

- [About Instrument Configurations](#)
- [Unit Configuration](#)
- [Product Info](#)
- [PoE Output](#)
- [Alarms & Other Indications](#)

PoE Output

PoE Output	State: Enable ▾
PSE Status	OK
PSE Error Code	Off

Options & Indicators:

- **State:** Allows you to **Enable/Disable** the POE Out for LAN2 (See Also [Establish Communication](#))
- **PSE Status:** Indicates the status of the LAN2/LCD port (Ok/ Fail)
- **PSE Error Code:** **Off** signifies that this port is not in use. **On** signifies that an LCD screen is currently attached to this port.
- To apply your changes select Apply Changes ➔ Refresh Data to review your changes
- To enforce your changes to your G4500/G3500 unit select Restart Unit

NOTE NOTE NOTE

- If you are not logged on as the [Administrator](#), you will not be able to change any of these settings & you will receive the following error message in your attempt to do so:

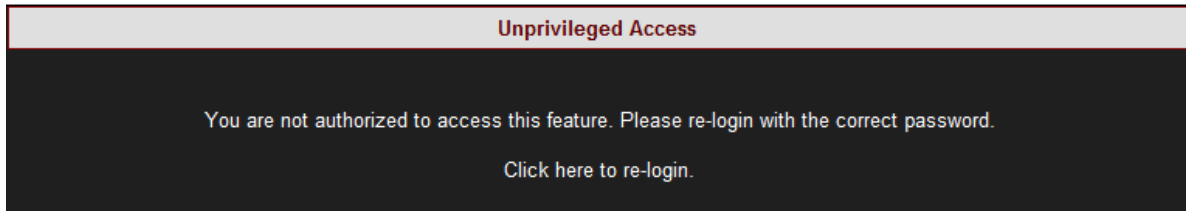

- Once you have signed on as the [Administrator](#), ensure that you select Apply Changes to actually affect your changes.

SEE ALSO:

- [About Instrument Configurations](#)
- [Unit Configuration](#)
- [Product Info](#)
- [Alarms & Other Indications](#)

Alarms & Other Indications

The Alarms that are selected in the **Device Info Window** below will set off a red led light on your Portable BLACKBOX alerting you on the failure accordingly. In addition, some Alarm/System/Misconfigurations may be displayed on the **Menu Path Bar** of the BLACKBOX's Web Interface. For your convenience the **R/O (Read Only) & Bandwidth** indications may be changed directly by clicking on the indication itself, without having to sign out / configure other settings. For **Power Indicators** see [Unit Powering](#).

- Select the applicable Alarm Configuration that you want to be displayed in the **Alarms Configuration Section**:

Alarms Configuration			
<input checked="" type="checkbox"/> General	<input checked="" type="checkbox"/> DSP Sync	<input checked="" type="checkbox"/> Time Sync	<input checked="" type="checkbox"/> PQZip
<input checked="" type="checkbox"/> FTP	<input checked="" type="checkbox"/> Flash	<input checked="" type="checkbox"/> Logger	<input checked="" type="checkbox"/> DSP
<input checked="" type="checkbox"/> Drop Data	<input checked="" type="checkbox"/> Misconfigured		

BLACKBOX RED ALARM INDICATORS:

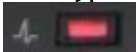
The table below outlines types of alarms that will set off the red alarm indicator light on your Portable BLACKBOX:  (Flashing/Solid) & to be displayed in the [System Log](#):

Alarm Type	Indication
General	Solid Red: General unit startup & system initiation. See Unit Powering
FTP	Flashing Red: Availability of the Network connection to the SNTP server. See BLACKBOX Unit & FTP Access
Drop Data	Flashing Red: Temporary loss of PQZIP data. About PQZIP Recording
DSP Sync	Solid Red: Verification unit synchronization with the network power. See Time
Flash	Solid Red: Successful transfer of data to the BLACKBOX's internal Flash memory. See Internal Memory Specifications
Misconfigured	Flashing Red: Verification of configured nominal value compared with the CT/PT value. See Quick Configuration
Time Sync	Flashing Red: Verification of the quality of the time synchronization (POOR or less). See Time
Logger	Flashing Red: Verification of a corrupted Logger. See System Log
PQZIP	Solid Red: Verification whether or not the PQZIP is enabled. See Enabling / Disabling PQZIP
DSP	Flashing Red: Communication verification between CPU with DSP module.

BLACKBOX BLUE ALARM INDICATORS

The alarm may also display a blue indicator light -  (Flashing/Solid):











Indicator	Indication
Flashing Blue	<ul style="list-style-type: none"> System Initiation. See Unit Powering
Solid Blue	<ul style="list-style-type: none"> Normal Operation If PQZIP Enabled - PQZIP Recording Active

BLACKBOX WEB INTERFACE ALARM INDICATORS:

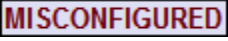
The table below outlines types of alarms that will set off the red alarm indicator light on the BLACKBOX's Web Interface:



As above the indicators will also be displayed in the [System Log](#):

Alarm Type	Indication
	Read Only privileges. You are signed on as a System User & cannot configure the unit. To log on as Admin see Unit Access or double click on the  & in the Password Text box enter the Admin password followed by Login : 
	Read & Write privileges. You are signed on as a System Administrator & you may configure the unit.
	The nominal CT/PT values have been misconfigured. See Quick Configuration
	You unit is not synchronized with the network power. See Time
	PQZIP Recording is disabled. See Enabling / Disabling PQZIP
 (Located Next to Menu Path)	Portable Unit has been successfully Accessed
 (Located Next to Menu Path)	Web session has been disconnected - See Accessed to re-access.
 (Located Next to Alarm)	Unit is working on either AC / Auxiliary Power Supply & the Battery is charging. Full green indicates the battery has been fully recharged.
 (Located Next to Alarm)	Your unit is mainly working on Battery Supply only, with time left on your Battery. See Unit Powering

- To apply your changes select  ➔  to review your changes

- To enforce your changes to your G4500/G3500 unit select **Restart Unit**

NOTE NOTE NOTE

- If you are not logged on as the [Administrator](#), you will not be able to change any of these settings & you will receive the following error message in your attempt to do so:

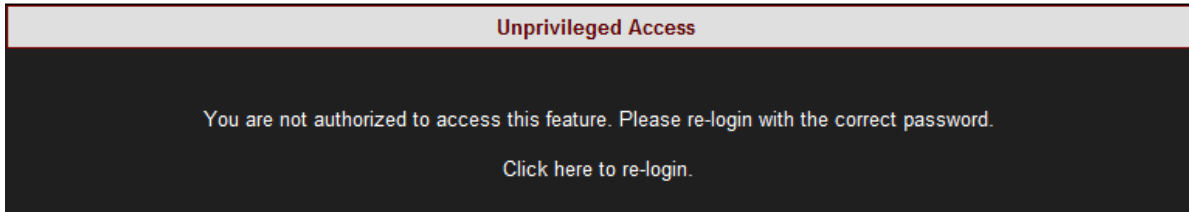

- Once you have signed on as the [Administrator](#), ensure that you select **Apply Changes** to actually affect your changes.

SEE ALSO:

- [About Instrument Configurations](#)
- [Unit Configuration](#)
- [Product Info](#)
- [PoE Output](#)

Time Settings - Time Synchronization

The Portable BLACKBOX contains a Time Synchronization module. This module maintains & tracks time that is being used by the entire BLACKBOX system and specifically by the PQZIP engine for storing continuous waveform recordings at an accurate time stamp. This allows you to compare & analyze time-synchronized data recorded by any number of BLACKBOX devices within a particular site or across many sites. The time sources are supported by:

- **Primary or Alternative SNTP Network Server:** The Server is an external server machine that provides SNTP Clients (such as a BLACKBOX or a PC) a time over IP network using SNTP standard protocol. Time Sync supports two SNTP Servers. The first is acting as primary, and the second is an alternative in case the primary is not available. SNTP server is identified by an Internet (IP) address. The BLACKBOX is basically acting as an SNTP Client that initiates time requests towards SNTP servers. However the BLACKBOX also acts as an SNTP time server, and therefore, it can respond and provide time for other BLACKBOX units that are configured to its SNTP server.
- **GPS Receiver:** The unit receives satellite signals & therefore requires special installation with a sky view or transponder from a GPS receiver with a sky view. A GPS unit provides location & time information via a serial port (typically RS232/RS485 communication port to the BLACKBOX). The GPS option is for remote sites where internet/intranet communication is not an option or, alternatively, network communication is poor.
- **RTC (Internal Real-Time Clock):** Is an internal unit of the Portable BLACKBOX unit that serves as a default time source when no other external source available. The RTC is powered by a battery to maintain clock progress even when the BLACKBOX device power is off.

The Time Sync module provides the BLACKBOX system with a global time format called GMT or UTC. Using a global time approach enables the BLACKBOX to synchronize measurements with other BLACKBOXs located somewhere else around the globe. While the time being recorded with PQZIP files is always GMT, the time shown on the BLACKBOX'S Web Interface on the bottom:

Unit Time 01/01/2012 02:32:49. The Local time is internally computed by the BLACKBOX from the UTC obtained from the Time SYNC module plus the Time Zone (which is the number of hours offset per specific country/area).

ACCESS TIME CONFIGURATION:

- [Access](#) your Portable Device via [Espec's Web Interface](#) ➡ log on as the **Administrator** ➡ under **Configuration** ➡ **Device Setup** select the **Time** Tab:

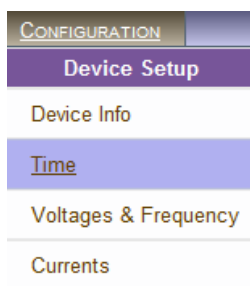

- The **Time Window** will now open:

RW ■ CONFIGURATION » TIME

Apply Changes
Refresh Data

Network Time

Transport	<input type="text" value="Automatic"/>
Main SNTP	<input type="text" value="169.169.169.169"/>
Alternate SNTP	<input type="text" value="169.169.169.169"/>
Using SNTP	Self
Slew Mode	<input type="text" value="Automatic"/>
Slew Factor	<input type="text" value="50"/> %
Step Time	<input type="text" value="10"/> Sec.

Time Setup

RTC Counter	1021:2:17:8 D:H:M:S	
Time Zone	<input type="text" value="UTC +2"/>	
Unit Date & Time	<input type="text" value="01/01/2012"/>	<input type="text" value="08:00:00"/>
Set Date & Time		

Daylight Saving

State	<input type="text" value="Disable"/>	
Start Time _{UTC}	<input type="text" value="01/05/2011"/>	<input type="text" value="00:00:00"/>
End Time _{UTC}	<input type="text" value="31/04/2012"/>	<input type="text" value="00:00:01"/>

- Within this window you'll be able to set and control the time:
 - Control the time synchronization of external time sources with [Network Time](#)
 - Set & control the internal clock of the Portable BLACKBOX PQA with [Setup the Time](#)
 - Automatically adjust the Portable BLACKBOX PQA with [Daylight Saving Time](#)

SEE ALSO:

- [Device Configuration Overview](#)
- [Device Info - Unit Configuration](#)
- [Voltage & Frequency](#)
- [Currents](#)

Time Setup

Time Setup	
RTC Counter	1021:2:17:8 D:H:M:S
Time Zone	UTC +2
Unit Date & Time	01/01/2012 08:00:00
<input type="button" value="Set Date & Time"/>	

This section is used to set and control the internal clock of the Portable BLACKBOX Unit. Set:

- **The RTC Counter:** Is used for setting the counting of the internal real time clock. The RTC starts its counting from the date of manufacture. RTC Counter format reads as: Days, Hours, Minutes, and Seconds
- **Time Zone:** Specifies the date and time to be presented on the BLACKBOX WEB interface (Unit Time 01/01/2012 02:32:49 bottom of the page). The presented time is the local time derived from the GMT time and the configured Time Zone which shifts the GMT time backward or forward in accordance. (Greenwich Mean Time (GMT) means time at Greenwich, London (Also referred to as UTC)
- **Unit Date & Time:** Utilized for setting the current time & date manually. Once you click on the configuration box, the date or time will instantly appear and you can set it. Click on the Set Date & Time button and the time is changed. However, if the unit's Time Synchronization module is synchronizing with an external source (like NTP or GPS), the time will be overridden as soon as the updates are received. To prevent automatic updates, set the Time Sync module on Self synchronization.
- To apply your changes select →
- To review your changes, select

NOTE NOTE NOTE

- If you are not logged on as the [Administrator](#), you will not be able to change any of these settings & you will receive the following error message in your attempt to do so:

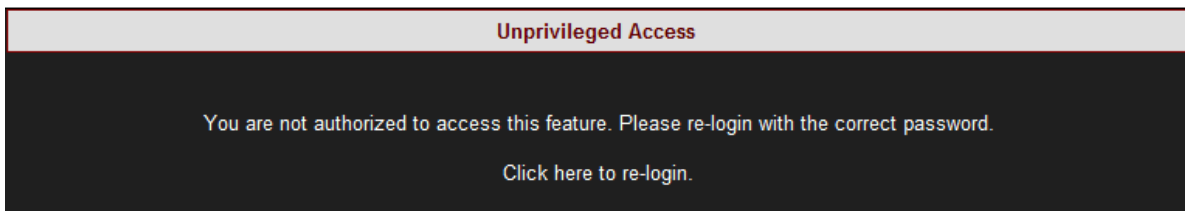

- Once you have signed on as the [Administrator](#), ensure that you select → to actually affect your changes.

SEE ALSO:

- [About Time Settings](#)
- [Network Time](#)
- [Daylight Saving](#)

Network Time

Network Time	
Transport	<input type="text" value="Automatic"/> <ul style="list-style-type: none"> Automatic GPS Only SNTP Only
Main SNTP	<input type="text" value="169.169.169.169"/>
Alternate SNTP	<input type="text" value="169.169.169.169"/>
Using SNTP	Self
Slew Mode	<input type="text" value="Automatic"/> <ul style="list-style-type: none"> Automatic Master Slave
Slew Factor	<input type="text" value="50"/> %
Step Time	<input type="text" value="10"/> Sec.

This section controls Time Synchronization with a variety external time sources. Make your changes according to your selection:

- **Transport:** Utilize this option to for the Time Sync Module to select the source **Automatically**, or to force the source Manually to **SNTP** or **GPS** source. To configure the GPS Source itself - see [GPS Configuration](#).
- **Main SNTP:** Use this option in order to configure the IP address of the Primary SNTP server to be used
- **Alternate SNTP:** Use this option to configure the IP address of the secondary SNTP server to be used (A contingency should the Primary Server become unavailable)
- **Slew Mode:** Set the type of Time Slewing/Adjustment to be used by the Time Sync module. This will compensate for time deviations and network communication jitters.
 - The default & preferred mode is **Automatic**, as the Slewing Factor is according to time source communication quality.
 - If you set the mode to **Master**, other units read the time from this unit & this units obtains the time either from an external SNTP/GPS.
 - **Slave** obtains the time settings from a **Master Unit** via SNTP
- To apply your changes select [Apply Changes](#) ➔ [Refresh Data](#) to review your changes

Note Note Note

- If you are not logged on as the [Administrator](#), you will not be able to change any of these settings & you will receive the following error message in your attempt to do so:

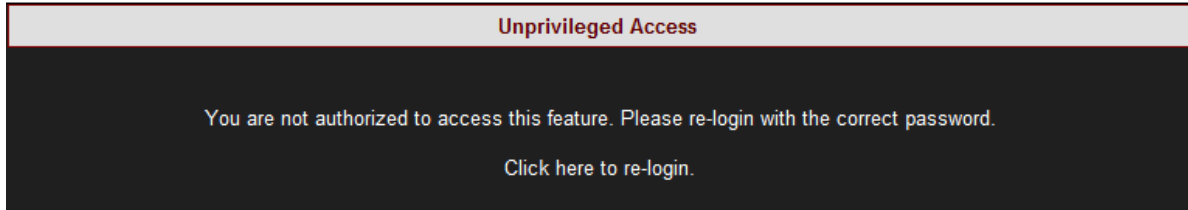

- Once you have signed on as the [Administrator](#), ensure that you select [Apply Changes](#) to actually affect your changes.

SEE ALSO:

- [About Time Settings](#)
- [Time Setup](#)
- [Daylight Saving](#)

Daylight Saving

Daylight Saving	
State	<div style="border: 1px solid black; padding: 2px;"> Disable ▾ Disable Enable </div>
Start Time _{UTC}	<div style="display: flex; gap: 10px;"> <div style="border: 1px solid gray; padding: 2px;">01/05/2011</div> <div style="border: 1px solid gray; padding: 2px;">00:00:00</div> </div>
End Time _{UTC}	<div style="display: flex; gap: 10px;"> <div style="border: 1px solid gray; padding: 2px;">31/04/2012</div> <div style="border: 1px solid gray; padding: 2px;">00:00:01</div> </div>

You can **Enable** the daylight saving time (Winter / Summer Clock) feature and set the period in this section. This will cause the time to automatically adjust to daylight savings time during the pre-defined period. This information is passed to the PQSCADA together with all other information via PQZIP where it is displayed to the user. To set the daylight saving time:

- Select **Enable**
- Enter Start / End Date & Time (UTC)
- To apply your changes select Apply Changes ➔ Refresh Data to review your changes

NOTE NOTE NOTE

- If you are not logged on as the [Administrator](#), you will not be able to change any of these settings & you will receive the following error message in your attempt to do so:

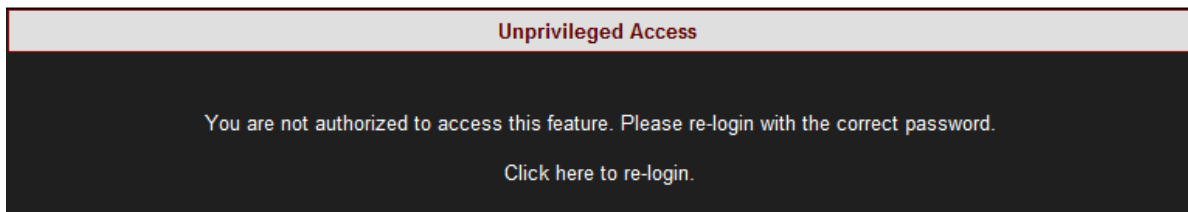

- Once you have signed on as the [Administrator](#), ensure that you select Apply Changes to actually affect your changes.

SEE ALSO:

- [About Time Settings](#)
- [Time Setup](#)
- [Network Time](#)

Voltage & Frequency

The purpose of this section is view, understand, or change configurations you made in your Initial Quick Configuration for your Voltage & Frequency values. The configurations are made for the Portable BLACKBOX after you have [Connected your Voltage Probes](#).

OPEN THE VOLTAGE & FREQUENCY WINDOW:

- [Access](#) your Portable Device via Elspec's Web Interface ➔ log on as the Administrator ➔ under Configuration ➔ Device Setup select the Voltage & Frequency Tab:

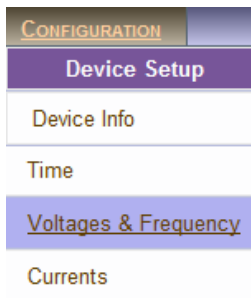

- The Voltage & Frequency window will now open:

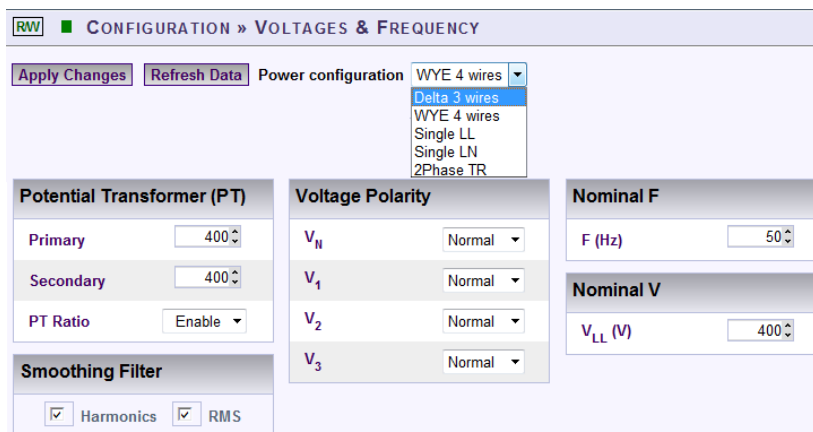
 The screenshot shows a web interface for 'CONFIGURATION » VOLTAGES & FREQUENCY'. It includes:

- Buttons: 'Apply Changes', 'Refresh Data', and a 'Power configuration' dropdown menu set to 'WYE 4 wires'.
- 'Potential Transformer (PT)' section: Primary (400), Secondary (400), and PT Ratio (Enable).
- 'Smoothing Filter' section: Checkboxes for 'Harmonics' and 'RMS'.
- 'Voltage Polarity' section: Four dropdown menus for V_N, V₁, V₂, and V₃, all set to 'Normal'.
- 'Nominal F' section: F (Hz) dropdown set to 50.
- 'Nominal V' section: V_{LL} (V) dropdown set to 400.

In this window you will be able to:

- [View / Change your Power Configurations](#)
- [View / Change your Potential Transformation Ratios](#)
- [Smooth the curve in significant change of PQ Parameter \(IEC61000-4-7 Compliance\)](#)
- [Toggle the polarity without rewiring](#)
- [Define nominal values for Voltage & Frequency](#)

SEE ALSO:

- [Device Configuration Overview](#)
- [Device Info - Unit Configuration](#)
- [Time Settings](#)
- [Currents](#)

Power Configuration

The network type settings are represented by five different configurations, although the actual number of supported networks could be extended to virtually any existing configuration. Refer to Other Connections in order to view the types of Power Topology the Portable BLACKBOX supports.

- The following table outlines the recommended configurations for several supported power types:

Power Type	BLACKBOX Web Interface Power Configuration
Single Phase with Neutral	Single LN
Single Phase without Neutral	Single LL
Single Split Phase	2Phase TR
Three Wire Delta	Delta 3 Wires
Grounded Delta	Delta 3 Wires
Four Wire WYE	WYE 4 Wires
Three Wire WYE	WYE 4 Wires
Delta High Leg	Delta 3 Wires
Delta Open Leg	Delta 3 Wires

- Select the applicable **Network Type Settings** according to your network type from the drop-down selection:

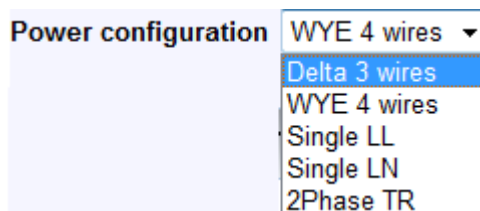

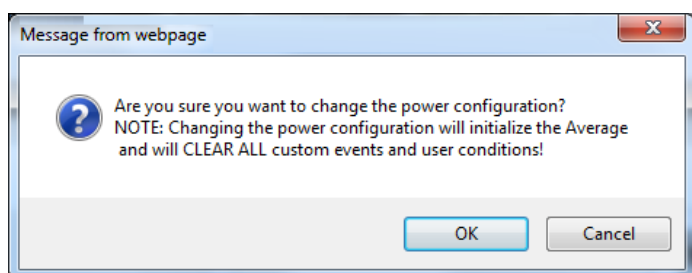

- To apply your changes select **Apply Changes**
- You will receive the following warning message as changing the network configuration will result in all the energy calculations to be averaged & will clear all your Custom Event configurations. Click **OK** in order to proceed:

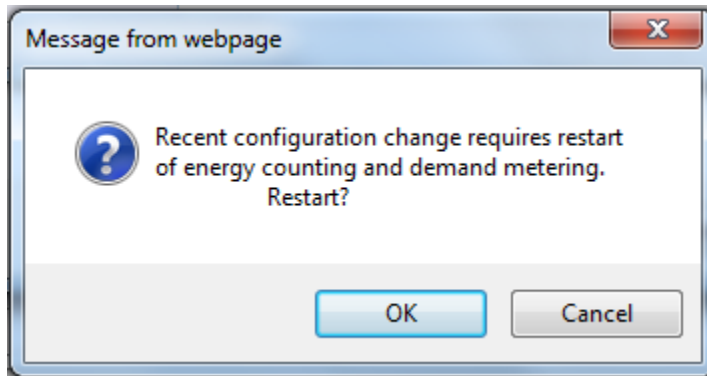

- You will receive a "Configuration Successful" message & will be prompted to initiate a restart of the energy calculations.

Click  in order to proceed:



- Review your changes by selecting 

NOTE NOTE NOTE

- If you are not logged on as the [Administrator](#), you will not be able to change any of these settings & you will receive the following error message in your attempt to do so:

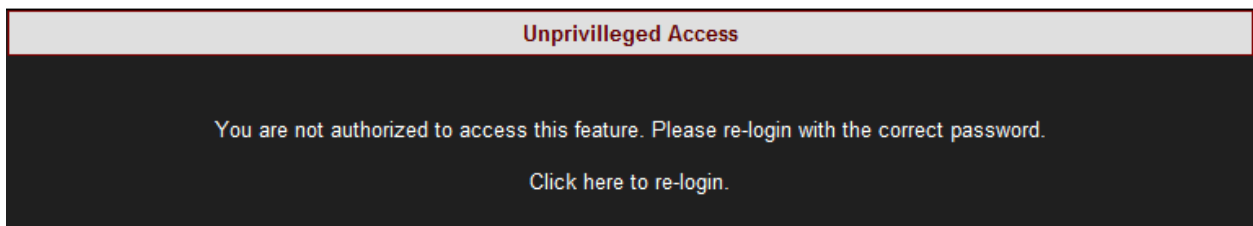

- Once you have signed on as the [Administrator](#), ensure that you select  to actually affect your changes.

SEE ALSO:

- [About the Voltage & Frequency Window](#)
- [Potential Transformer](#)
- [Smooth Filtering](#)
- [Voltage Polarity](#)
- [Nominal](#)

Potential Transformer

Potential Transformer configuration is required only for MV/HV networks where the voltage is measured using PT's. This option allows you to accurately configure the known transformation ratio in both magnitude and phase, over a range of measuring circuit impedances. The voltage transformer is intended to present a negligible load to the supply being measured. The low secondary voltage allows protective relay equipment and measuring instruments to be operated at lower voltages.

- If you wish to measure the Potential Transformer (MV/HV Networks - Voltage Measurements by PT's) select **Enable**:

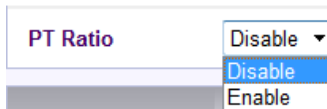

A screenshot of a web interface showing a dropdown menu for 'PT Ratio'. The menu is open, showing three options: 'Disable' (selected), 'Disable', and 'Enable'.

- Set the correct **Primary & Secondary Ratio** (with ▲/▼):

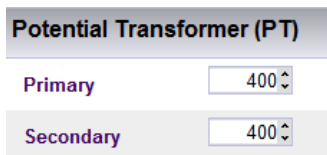

A screenshot of the 'Potential Transformer (PT)' configuration section. It shows two input fields: 'Primary' with a value of 400 and 'Secondary' with a value of 400. Both fields have up and down arrows for adjustment.

If the PT Ratio is inapplicable, then set your values to read:

Primary = Secondary = Nominal

- To apply your changes select **Apply Changes** → **Refresh Data** to review your changes

NOTE NOTE NOTE

- If you are not logged on as the [Administrator](#), you will not be able to change any of these settings & you will receive the following error message in your attempt to do so:

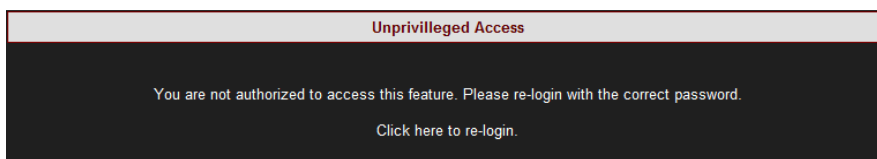

- Once you have signed on as the [Administrator](#), ensure that you select **Apply Changes** to actually affect your changes.

SEE ALSO:

- [About the Voltage & Frequency Window](#)
- [Power Configuration](#)
- [Smooth Filtering](#)
- [Voltage Polarity](#)
- [Nominal](#)

Smooth Filtering

This filter is introduced according to IEC standard 61000-4-7. It allows (enabled) smoothing of the curve when there are fluctuations in a power quality parameter such as in Harmonics / RMS.

- Mark the **Applicable Parameter** for filtering (Harmonics & / RMS):

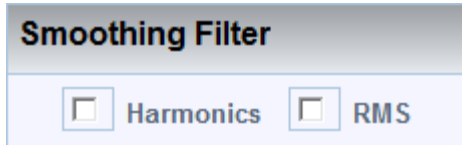

- To apply your changes select **Apply Changes** → **Refresh Data** to review your changes

NOTE NOTE NOTE

- If you are not logged on as the [Administrator](#), you will not be able to change any of these settings & you will receive the following error message in your attempt to do so:

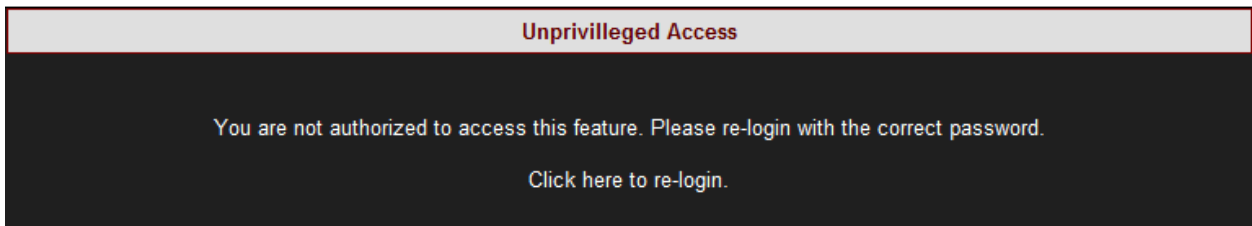

- Once you have signed on as the [Administrator](#), ensure that you select **Apply Changes** to actually affect your changes.

SEE ALSO:

- [About the Voltage & Frequency Window](#)
- [Power Configuration](#)
- [Potential Transformer](#)
- [Voltage Polarity](#)
- [Nominal](#)

Voltage Polarity

Wiring errors usually result into an incorrect polarity. The Voltage Polarity settings allow you to toggle the polarity without the necessity of rewiring.

- Either **Reverse** the polarity / maintain it at **Normal** from the drop-down selection:

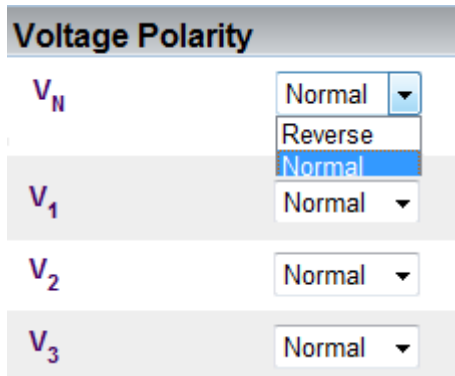

Voltage Polarity	
V _N	Normal ▼
V ₁	Normal ▼
V ₂	Normal ▼
V ₃	Normal ▼

- To apply your changes select **Apply Changes** → **Refresh Data** to review your changes

NOTE NOTE NOTE

- If you are not logged on as the [Administrator](#), you will not be able to change any of these settings & you will receive the following error message in your attempt to do so:

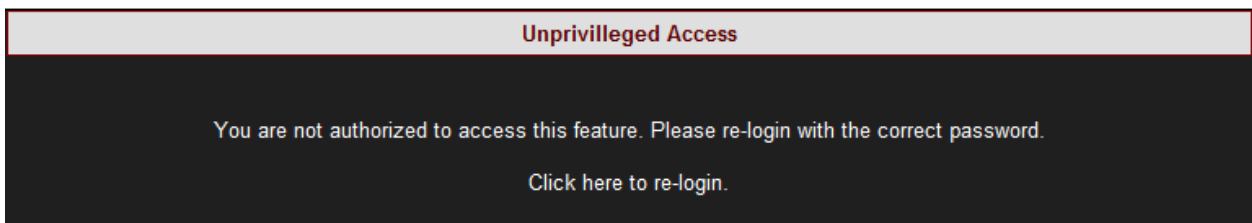

- Once you have signed on as the [Administrator](#), ensure that you select **Apply Changes** to actually affect your changes.

SEE ALSO:

- [About the Voltage & Frequency Window](#)
- [Power Configuration](#)
- [Potential Transformer](#)
- [Smooth Filtering](#)
- [Nominal](#)

Define Nominal Values

The Nominal section defines the nominal values for Frequency (F) and Voltages (V). The Frequency nominal effects compliance. For example, when 50Hz nominal is set, the window is 10 cycles, and for 60Hz the window is 12 cycles.

- For HV & MV Networks, define the **Nominal Values for Frequency (F) and Voltages (V)** (with ▲/▼):

Nominal F	
F (Hz)	50

Nominal V	
V _{LL} (V)	400

- The ratio for LV Networks is based on the same concept & specifications - Define the **Nominal Values for Frequency (F) and Voltages (V)** (with ▲/▼):

Nominal F	
F (Hz)	50

Nominal V	
V _{LL} (V)	230

If the PT Ratio is inapplicable, then set your values to read:

Primary = Secondary = Nominal

- To apply your changes select **Apply Changes** ➔ **Refresh Data** to review your changes

NOTE NOTE NOTE

- Should you enter incorrect nominal values, the device may not record anything.
- For maximum logging resolution and efficiency it is recommended keeping NOMINAL values as close to the expected normal condition values and NOT to maximum values!
- FOR NOMINAL V VALUES:** If you are using a [Potential Transformer \(PT\) Configuration](#) for MV/HV networks, the Nominal V values needs to be set to the [PT values](#).
- If you are not logged on as the [Administrator](#), you will not be able to change any of these settings & you will receive the following error message in your attempt to do so:

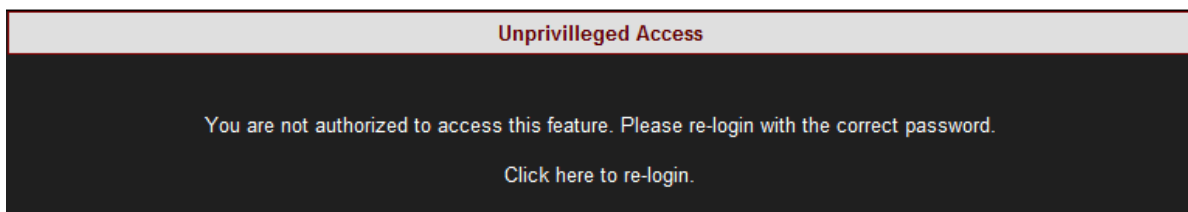

- Once you have signed on as the [Administrator](#), ensure that you select **Apply Changes** to actually affect your changes.

SEE ALSO:

- [About the Voltage & Frequency Window](#)
- [Power Configuration](#)
- [Potential Transformer](#)
- [Smooth Filtering](#)
- [Voltage Polarity](#)

Current

The purpose of this section is view, understand, or change configurations you made in your [Initial Quick Configuration](#) for your Current values. The configurations are made for the Portable BLACKBOX after you have [Connected your Current Probes](#).

ACCESS / CHANGE YOUR VOLTAGE & FREQUENCY CONFIGURATIONS:

- [Access](#) your Portable Device via Elspec's Web Interface ➔ log on as the Administrator ➔ under Configuration ➔ Device Setup select the Currents Tab:



- The Currents window will now open:

RW ■ CONFIGURATION » CURRENTS

Apply Changes
Refresh Data

Current Probes Info

Channel	CT Ratio (A)		Nominal (A)	Polarity	Clamp Info	Behavior simulation
	Primary	Secondary				
I ₁	<input type="text" value="3000"/>	<input type="text" value="3000"/>	<input type="text" value="1"/>	Normal ▾	Custom Clamp I ₁	No Simulation ▾
I ₂	<input type="text" value="300"/>	<input type="text" value="300"/>	<input type="text" value="1"/>	Normal ▾	Custom Clamp I ₂	No Simulation ▾
I ₃	<input type="text" value="30"/>	<input type="text" value="30"/>	<input type="text" value="1"/>	Normal ▾	Custom Clamp I ₃	No Simulation ▾
I _N	<input type="text" value="3000"/>	<input type="text" value="3000"/>	<input type="text" value="1"/>	Normal ▾	Flex clamp-3000A	Flex clamp-300A ▾
I ₅	<input type="text" value="30"/>	<input type="text" value="30"/>	<input type="text" value="1"/>	Normal ▾	Custom clamp I ₅	No Simulation ▾

Custom/DC probes Info

Clamp Info	I/V Ratio		Hardware Range
	Current	Voltage	
Custom Clamp I ₁	<input type="text" value="1"/>	<input type="text" value="0.1"/>	70.710678 A ▾
Custom Clamp I ₂	<input type="text" value="1"/>	<input type="text" value="0.01"/>	707.106787A ▾
Custom Clamp I ₃	<input type="text" value="1"/>	<input type="text" value="0.001"/>	7071.067871 A ▾
Custom Clamp I ₅	<input type="text" value="1"/>	<input type="text" value="0.001"/>	7071.067871 A ▾

Non-measured Currents

Calculated Phase
All Present ▾

- As mentioned previously, once you have [Connected your Current Probes](#) it will be automatically recognized. If you have already [Configured your Current Inputs](#) you may also in this window:
 - View / Change the CT Ratios, Nominal Values, Polarity & Behavior Simulation in the [Current Probes Info Section](#),
 - View / Change the I/V Ratios & Hardware Range in the [Custom/DC Probes Info Section](#), & / or
 - View / Change calculated current channels in the [Non-measured Currents Section](#)

NOTE NOTE NOTE

- If you are not logged on as the [Administrator](#), you will not be able to change any of these settings & you will receive the following error message in your attempt to do so:

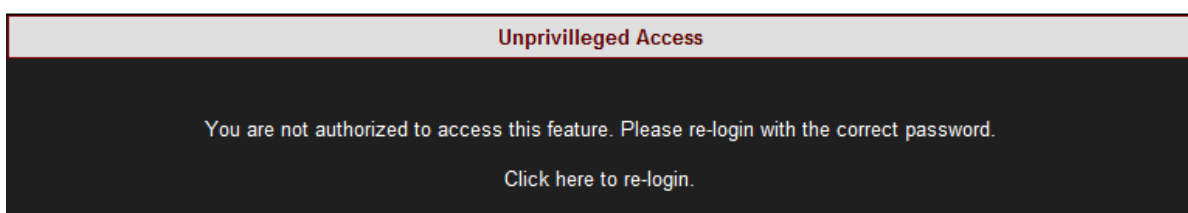

- Once you have signed on as the [Administrator](#), ensure that you select [Apply Changes](#) to actually affect your changes.

SEE ALSO:

- [Device Configuration Overview](#)
- [Device Info - Unit Configuration](#)
- [Time Settings](#)
- [Voltage & Frequency](#)

Current Probes Info

On the successful [Current Probe\(s\) Connection](#) the probes will be automatically recognized & the status for the probes will appear in this section. Apart from Elspec Custom / any other Custom Clamp the **Behavior Simulation** will automatically displayed for the clamp. You may choose to change the simulation for this clamp; however once you have selected "No Simulation" you will need to set the [Hardware Range](#) for each clamp. The purpose of this chapter is to provide additional information further [Previous Current Probe Configurations](#).

RW ■ CONFIGURATION » CURRENTS						
<input type="button" value="Apply Changes"/> <input type="button" value="Refresh Data"/>						
Current Probes Info						
Channel	CT Ratio (A)		Nominal (A)	Polarity	Clamp Info	Behavior simulation
	Primary	Secondary				
I ₁	<input type="text" value="3000"/>	<input type="text" value="3000"/>	<input type="text" value="1"/>	Normal ▾	Custom Clamp I ₁	No Simulation ▾
I ₂	<input type="text" value="300"/>	<input type="text" value="300"/>	<input type="text" value="1"/>	Normal ▾	Custom Clamp I ₂	No Simulation ▾
I ₃	<input type="text" value="30"/>	<input type="text" value="30"/>	<input type="text" value="1"/>	Normal ▾	Custom Clamp I ₃	No Simulation ▾
I _N	<input type="text" value="3000"/>	<input type="text" value="3000"/>	<input type="text" value="1"/>	Normal ▾	Flex clamp-3000A	No Simulation ▾ No Simulation Flex clamp-300A
I ₅	<input type="text" value="30"/>	<input type="text" value="30"/>	<input type="text" value="1"/>	Normal ▾	Custom clamp I ₅	No Simulation ▾

VIEW / CHANGE THE CT RATIOS:

Configuration options are directly dependent on the probe type, for instance the [Mini Clamp 1A/1V](#) is normally used to measure a Secondary current of a current transformer (CT). In that case, the CT should be defined as Primary/Secondary values.

- For each respective clamp simply add the **Primary / Secondary** Ampere values:

CT Ratio (A)	
Primary	Secondary
<input type="text" value="3000"/>	<input type="text" value="3000"/>
<input type="text" value="300"/>	<input type="text" value="300"/>
<input type="text" value="30"/>	<input type="text" value="30"/>
---	---
<input type="text" value="50"/>	<input type="text" value="50"/>

Set the CT Ratio according to the Clamp Manufacturer's Specifications & not just the Ratio.

VIEW / CHANGE THE NOMINAL VALUES:

Nominal (A) value plays an important role for the [PQZIP](#) recording functionality. In the event that the probe is identified, the value is automatically set to probe default.

- For each respective clamp correct the applicable **Nominal Ampere** values if necessary:

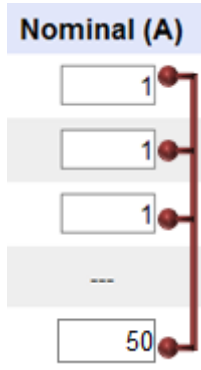

VIEW / CHANGE THE CURRENT POLARITY:

Polarity toggling is used to correct incorrect wiring.

- Either Reverse the polarity / maintain it at Normal from the drop-down selection:

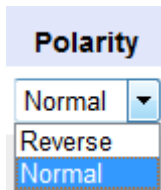

SIMULATE THE FLEX 300A & 3000A CLAMP BEHAVIORS:

Behavior simulations are only applicable to the [300 & 3000 A Flexible Clamps](#). This setting allows you to simulate the behavior of either clamp at either 300 / 3000 A. You may also choose not to simulate any of the behaviors.

- After you have set the CT Ratios, Nominal Values & Current Polarity, simply select the applicable **Simulation** option in the **Behavior Simulation** column:

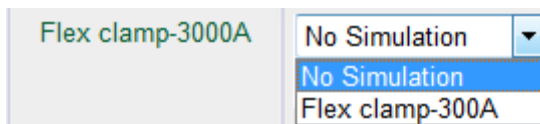

- To apply your changes select **Apply Changes** → **Refresh Data** to review your changes

NOTE NOTE NOTE

- If you are not logged on as the [Administrator](#), you will not be able to change any of these settings & you will receive the following error message in your attempt to do so:

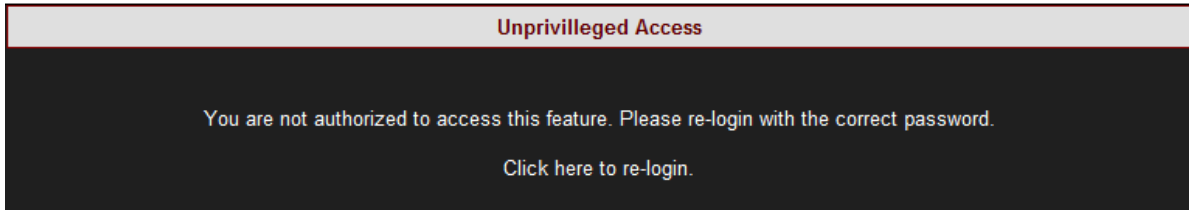

- Once you have signed on as the [Administrator](#), ensure that you select [Apply Changes](#) to actually affect your changes.

SEE ALSO:

- [About the Current Window](#)
- [Current Probes Info](#)
- [Custom DC Probes Info Section](#)
- [Non-Measured Currents](#)

Custom DC Probes Info

With the BLACKBOX Portable you may use any clamp in addition to the [Custom & Other Clamps](#) supplied by Elspec. This section will allow you to set the **Voltage/Current Ratio** & the **Hardware Range** for any custom and or [Elspec Custom Clamp](#). Ensure that you set the ratio & range is set according to the Clamp Manufacturer's Specifications & not just the Ratio & Range.

TABLE - V/I RATIOS PORTABLE BLACKBOX CUSTOM CLAMPS:

The 3-Phase AC flexible current clamps are now obtainable from Elspec as [Optional Accessories](#) with the BLACKBOX Portable. The clamps are capable of measuring currents up to 3000 Amps at very high frequencies of 10 kHz. The clamps are supplied either as 3-flexible current probes / 1-flexible current probe. Controlled by a Rotary-Switch with 1000 hour battery life, the probes provide a linear voltage output replicating input waveforms current ranges (determined by the user) of 30, 300, or 3000 Amperes.

The table below outlines the CT Ratio's for the Portable BLACKBOX Custom Clamps:

Custom Clamps	Rotary-Switch Current Setting	I/V Ratio
Flexible Custom Clamp	30 A	100 m V/A
Flexible Custom Clamp	300 A	10 m V/A
Flexible Custom Clamp	3000 A	1 m V/A

SET THE V/I RATIOS & HARDWARE RANGE FOR THE CUSTOM CLAMPS:

- Once you have completed the [Current Probes Info](#) section, you may proceed into setting V/I Ratios & Hardware Range for any plugged in Clamps. As mentioned previously the clamps are automatically be recognized once plugged in, and as such any Custom clamp will appear in the Custom DC Probes Info section (marked in Blue):

NEW CONFIGURATION » CURRENTS

Apply Changes Refresh Data

Current Probes Info

Channel	CT Ratio (A)		Nominal (A)	Polarity	Clamp Info	Behavior simulation
	Primary	Secondary				
I ₁	3000	3000	1	Normal	Custom Clamp I ₁	Auto simulation
I ₂	3000	3000	1	Normal	Custom Clamp I ₂	Auto simulation
I ₃	3000	3000	1	Normal	Custom Clamp I ₃	Auto simulation
I ₄	3000	3000	1	Normal	Flex clamp-3000A	Flex clamp-300A
I ₅	3000	3000	1	Normal	Custom clamp I ₅	Auto simulation

Custom/DC probes Info

Clamp Info	Current	Voltage	Hardware Range
Custom Clamp I ₁	1	0.001	7071.067871 A
Custom Clamp I ₂	1	0.001	7071.067871 A
Custom Clamp I ₃	1	0.001	7071.067871 A
Custom Clamp I ₅	1	0.001	7071.067871 A

- Simply set the **Ratio & Hardware Range** according to the Clamp Manufacturer's Specifications:

Custom/DC probes Info

Clamp Info	I/V Ratio		Hardware Range
	Current	Voltage	
Custom Clamp I ₁	1	0.001	7071.067871 A
Custom Clamp I ₂	1	0.001	7071.067871 A
Custom Clamp I ₃	1	0.001	7071.067871 A
Custom Clamp I ₅	1	0.001	7071.067871 A

- To apply your changes select **Apply Changes** → **Refresh Data** to review your changes

Note Note Note

- If you are not logged on as the [Administrator](#), you will not be able to change any of these settings & you will receive the following error message in your attempt to do so:

Unprivileged Access

You are not authorized to access this feature. Please re-login with the correct password.

[Click here to re-login.](#)

- Once you have signed on as the [Administrator](#), ensure that you select **Apply Changes** to actually affect your changes.

SEE ALSO:

- [About the Current Window](#)
- [Current Probes Info](#)
- [Non-Measured Currents](#)

Non-Measured Currents

One of the three-phase current channels could optionally be calculated from the $I_1+I_2+I_3=0$. The Non-measured Current section helps to configure calculated current channels. There are two calculation options & they differ for:

- WYE Network - Refer to [Topology Configuration](#)
- DELTA & Single Split Phase Network - Refer to [Topology Configuration](#)

CONFIGURING CALCULATED CURRENT CHANNELS FOR WYE NETWORKS:

- Ensure the Power Configuration coincides with your Network
- In the Non-Measured Currents section, select the applicable phase to be calculated:

Non-measured Currents	
Calculated Phase	All Present ▾
	All Present
	L1 Absent
	L2 Absent
	L3 Absent
	In calculated

Calculation is based on Kirchhoff's laws - everything that comes in must go out, in order for the calculation of one of the current line to be based on the other measured lines instead of measuring it. For example when L_x is Absent it is being calculated using the other lines instead of measuring it. Or the neutral current I_N could be optionally calculated from the sum of three-phase currents, or alternatively, measured by the I_4 current channel.

CONFIGURING CALCULATED CURRENT CHANNELS FOR DELTA AND SINGLE SPLIT PHASE NETWORKS:

- Ensure the Power Configuration coincides with your Network
- In the Non-Measured Current section, select the applicable phase to be missed:

Non-measured Currents	
Missed Phase	All Present ▾
	All Present
	L1 Absent
	L2 Absent
	L3 Absent

One of the three-phase current channels could optionally be calculated from the $I_1+ I_2+ I_3=0$

SEE ALSO:

- [About the Current Window](#)
- [Current Transformer](#)
- [Current Polarity](#)

Communication - Configuration

The Portable BLACKBOX has various communication gateways & ports allowing for quick portable access, over any network from any location. The only difference between the two devices lies in the number of communication ports of the G4500 & G3500 Portable BLACKBOX, and how they are subsequently configured. In addition to the wireless communication, the G4500 has 3 communication ports including two isolated serial communication RS232 & RS485/422 ports. The G4500's USB port is used for connecting a Wireless USB stick for improved network communication. The G3500 hosts 1 LAN communication port including two serial ports RS232 & RS485/422.

ABOUT THE WIRELESS COMMUNICATION & COMMUNICATION PORTS OF THE G4500:



- **Wireless Communication:** Equipped with a built-in IEEE 802.11 g/b router configured as an industry standard access point, the G4500 provides convenient & instant connectivity to your G4150, including to a PC/Laptop that is Wi-Fi enabled.



The G4500 has 3 fast Ethernet link 10/100Mb ports in addition to the wireless access point:

- **Wide Area Network (WAN):** Designed to connect the device's internal LAN with other types of networks. It is commonly used to provide internet accessibility over an external Broadband router (Cellular, ADSL or Cable).
- **LAN1:** The main Ethernet port with DHCP server configured as active. This port is the main choice for either the G4150 Mobile Analysis Lab, or standalone PC, or Laptop connection with the unit.
- **LAN2/LCD:** Direct connection port to the BLACKBOX device, bypassing the internal router. This port is mainly suitable for connecting the unit with a local LAN of computers or G4100 LCD unit. It may also be used for either the G4150 Mobile Analysis Lab, or standalone PC, or Laptop connection with the unit.

ABOUT THE COMMUNICATION PORTS OF THE G3500:



The G3500 is equipped only a **LAN** communication port. This port acts either as the main Ethernet port with the DHCP server activated, or connecting the unit with a local LAN of computers, or the G4150 Mobile Analysis Lab, or standalone PC, or a Laptop.

ABOUT THE SERIAL PORTS OF THE PORTABLE BLACKBOX:



The Portable BLACKBOX is equipped with 2 isolated Serial Communication interfaces, namely:

- **RS232:** A standard DTE (Data Terminal Equipment) interface suitable for direct communication with COM compatible interface, such as a standard PC serial COM port.
- **RS485/422:** A standard RS485 (full duplex) or RS422 (half duplex) interface.

The procedure for establishing Communication with your Portable BLACKBOX includes:

- [Setting Web Entry Passwords & Providing Access to the FTP Server](#)
- [Establish All Network Communication Settings](#)
- [Configure RS485/RS422 interface parameters in Serial Ports](#)

SEE ALSO:

- [About Connecting Communication Ports](#)

Security

In this window you can set either Entry Passwords to the Web Interface and/or Provide Access to the FTP Server for your G4500/G3500 Portable BLACKBOX.

- [Access](#) the Portable BLACKBOX via Elspec's Web Interface ➔ log on as the Administrator ➔ select the **Configuration Tab**
- Under **Communication** select the **Security Tab**:

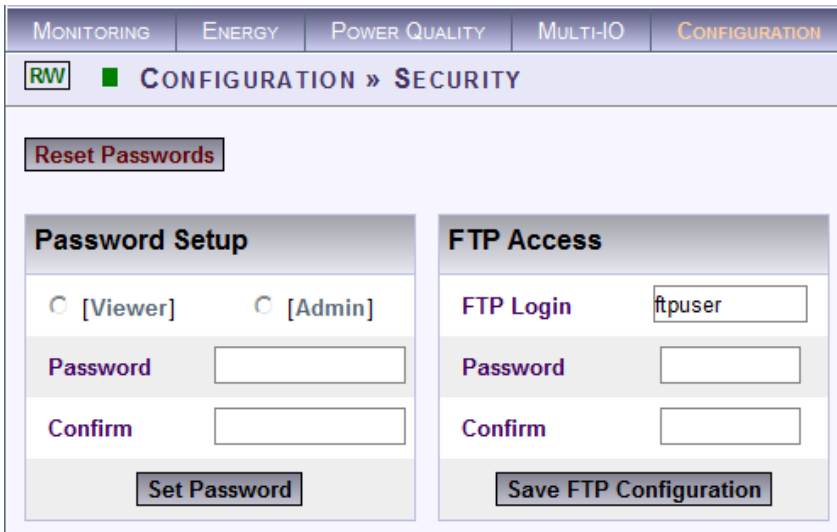

PASSWORD SETUP:

This section enables the Administrator to change or reset the passwords of **Viewer** & **Administrator** levels at one option at a time:

- Select either the **Viewer** or **Admin** option:

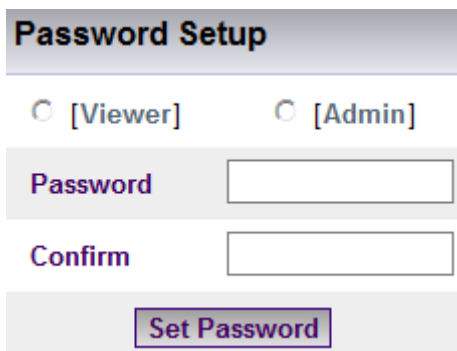

Levels:

- **Viewer:** Users are able to view all the functions within Elspec's Web Interface, but are unable to configure the Portable BLACKBOX (Manufacturer's Default Password is 123)
- **Admin:** Usually the Administrator of the Portable BLACKBOX, is able to view & configure the unit (Manufacturer's Default Password is 12345)
- Enter & Confirm the Password ➔ select **Set Password**
- To Reset the passwords to the Manufacturer's Default passwords select **Reset Passwords**

FTP ACCESS:

The Portable BLACKBOX includes a FTP server which is accessed via the PQSCADA / Elspec's Search Utility in order to retrieve the PQZIP files recorded by the unit. The PQZIP files may be manually retrieved by initiating an FTP session with the BLACKBOX device. The FTP Access section below controls the FTP Login and FTP Password for security measures.

- Enter the **User Login**, **Password** & **Confirm the Password** (Manufacture's Default Login is ftpuser & Password is ftppassword)

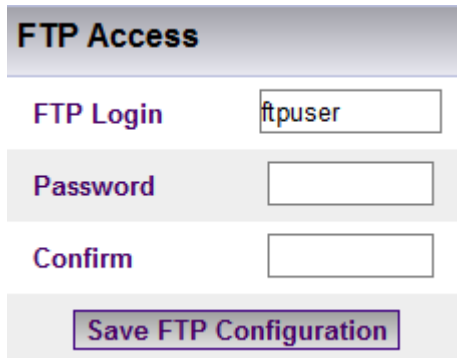

- Enter & Confirm the Password → select **Save FTP Configuration**
- To Reset the passwords to the Manufacture's Default passwords select **Reset Passwords**

NOTE NOTE NOTE

Changes made in the FTP Access section needs to be duplicated in the PQSCADA Configuration. (In the F1 Help Wizard of the PQSCADA, follow the Components → Nodes → Configuration → Device procedure)

SEE ALSO:

- [About BLACKBOX's Communication Configuration](#)
- [Network](#)
- [Serial Ports](#)
- [About Connecting Communication Ports](#)

Network - About Network Setup

The Network setup is a crucial part of your Portable BLACKBOX's unit configuration, as it establishes communication with your Portable BLACKBOX. It also establishes the IP Address of your G4500/G3500 Unit in the network. It includes:

For the G4500 Portable BLACKBOX:

- [Wi-Fi: Wireless Connection](#)
- [WAN: Broadband router \(ADSL/ Cable / Cellular\) for Internet accessibility](#)
- [LAN1: G4150/ DHCP/ PC / Laptop Connection](#)
- [LAN2: Direct connection to LAN Network of Computers / G4100](#)

For the G3500 Portable BLACKBOX:

- [LAN/LCD: Main connection port \(G4150/ DHCP / PC/ Laptop/ LAN Network of Computers/G4100\)](#) (On the devices' Web Interface configuration it is displayed as LAN2/LCD).

In General:

- [Send Data & Notifications from your Portable BLACKBOX by providing Outer Access](#)
- [Make allowances for Remote Access by configuring the Port Setup](#)
- [View the Status Summaries of your G4500/G3500 Device's Network Configurations](#)

OPEN THE NETWORK WINDOW:

- [Access](#) the Portable BLACKBOX's Configuration via [Espec's Web Interface](#) ➡ log on as the **Administrator** ➡ select the **Configuration Tab**
- Under **Communication** select the **Network Tab**:

Device Setup
Device Info
Time
Voltages & Frequency
Currents
Communication
Security
Network
Serial Ports
PQ Compliance
Power Compliance
User Defined Page 1
User Defined page 2
User Defined page 3

- The **Network Window** will now open:

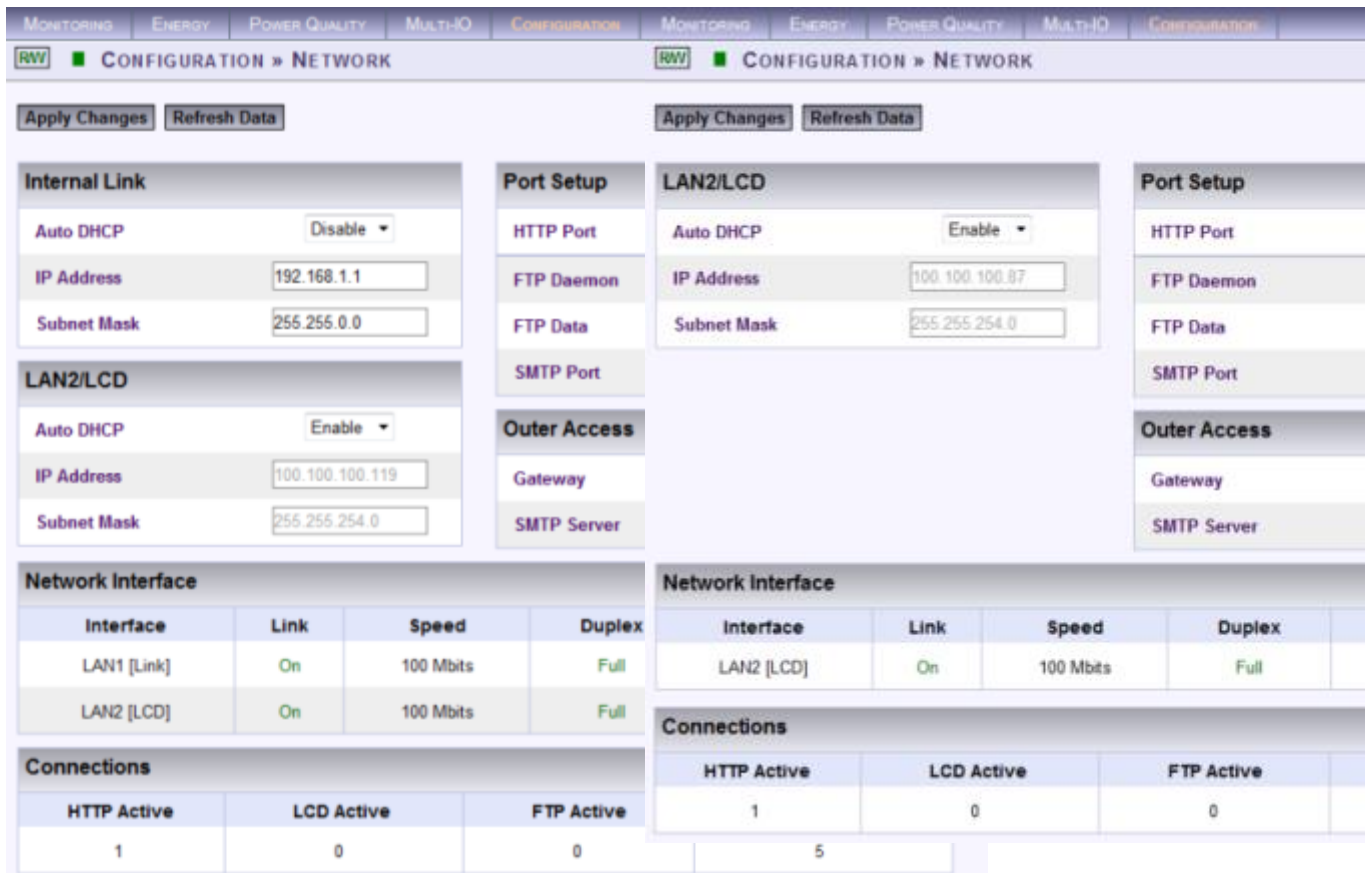

G4500 BLACKBOX Network Configuration

G3500 BLACKBOX Network Configuration

NOTE NOTE NOTE

If you are not logged on as the Administrator, you will not be able to change any of these settings & you will receive the following error message in your attempt to do so:

Unprivileged Access

You are not authorized to access this feature. Please re-login with the correct password.

[Click here to re-login.](#)

SEE ALSO:

- [About BLACKBOX's Communication Configuration](#)
- [Security](#)
- [Serial Ports](#)
- [About Connecting Communication Ports](#)

Wi-Fi Connectivity (G4500 Only)

The G4500 contains an integrated IEEE 802.11g/b router pre-configured as an industry standard access point. This is to provide the most convenient and simplest connectivity with the G4150 Mobile Analysis Lab or any other laptop or desktop Wi-Fi-Enabled PC. The internal Wi-Fi Access Point is configured by the factory default as a non-secure network. The SSID name is configured as the G4500's serial number.

CONNECT TO THE WIFI:

- After you have switched on your G4500 Portable PQ Analyzer, search for the device by its unique S/N on your Control Panel (Network & Sharing Center):

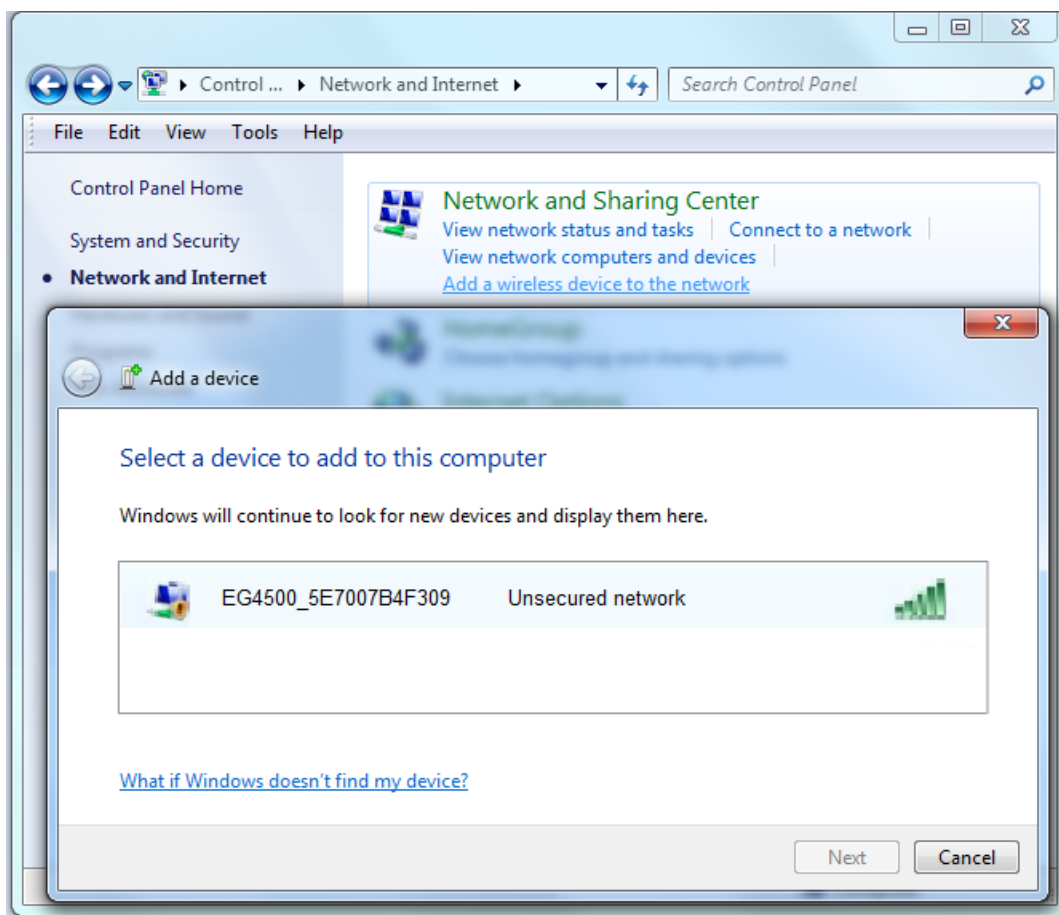

- The S/N is located on the G4500's name plate:



- The Wi-Fi Activity Indicator will confirm connection (Flashing / Solid Blue):



Alternatively, you may choose to simply configure the G4500's internal router & verify settings by using the Internet Explorer's Setup Wizard for WLAN Broadband Router configurations.

ACCESS & CONFIGURE THE WIRELESS ROUTER:

The procedure for configuring the G4500's internal router is fairly easy & the Setup Wizard will guide you through the procedure:

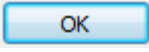
- Open the **Internet Explorer** on either the G4150 or any other Wi-Fi enabled PC/Laptop
- Type in the routers IP Address - **http://192.168.2.1** into in the Internet Explorer's address line & select **Enter**.
- Enter the User name as **admin** → password as **1234** → select  :



- The Router's configuration page will now automatically open. Open the **Interface Tab**:

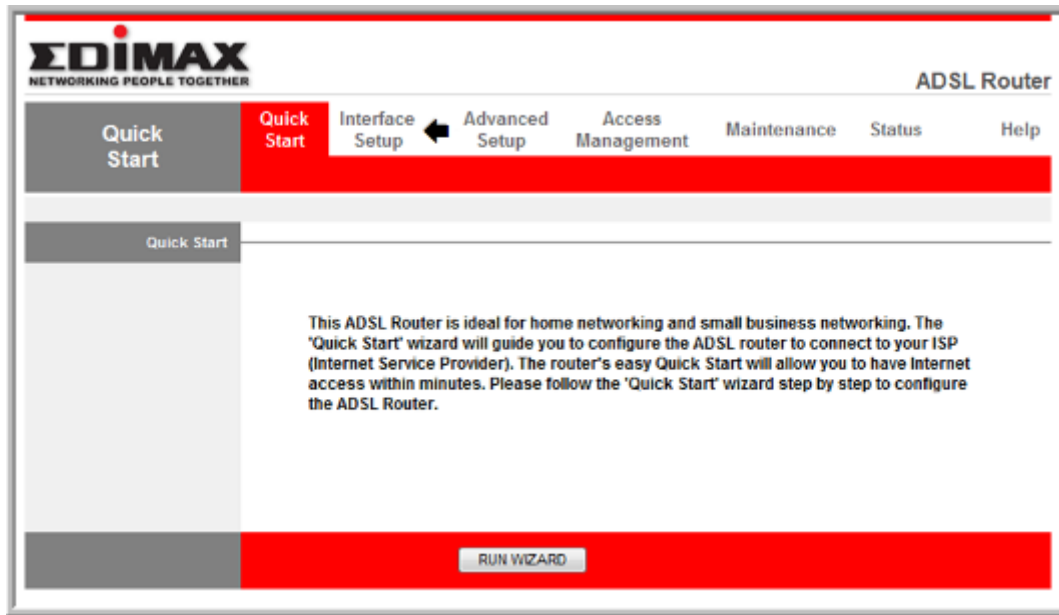

- Open the LAN Tab:

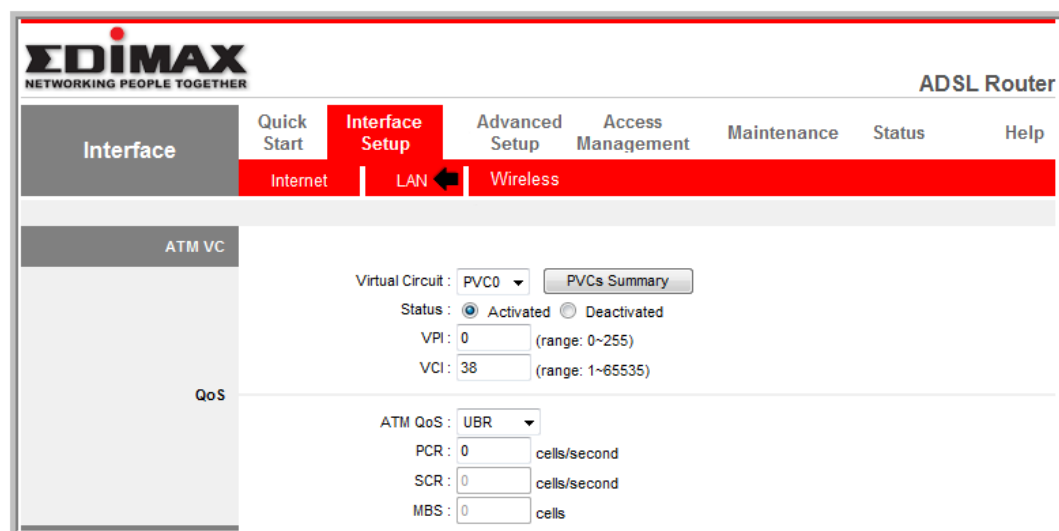

- Select or complete the following in the applicable sections → select **SAVE**:

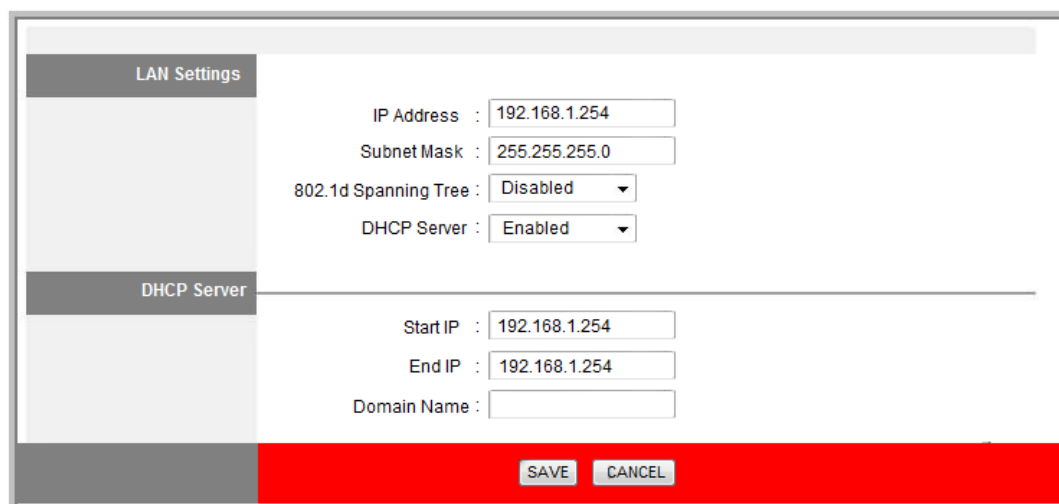

LAN Settings:

- **IP Address:** 192.168.1.254
- **Subnet Mask:** 255.255.255.0
- **802.1d Spanning Tree:** Disabled
- **DHCP Server:** Enabled

DHCP Server Settings:

- **Start IP:** 192.168.1.254
- **End IP:** 192.168.1.254
- **Domain Name:** No need to complete

- Open the **Wireless Tab**:

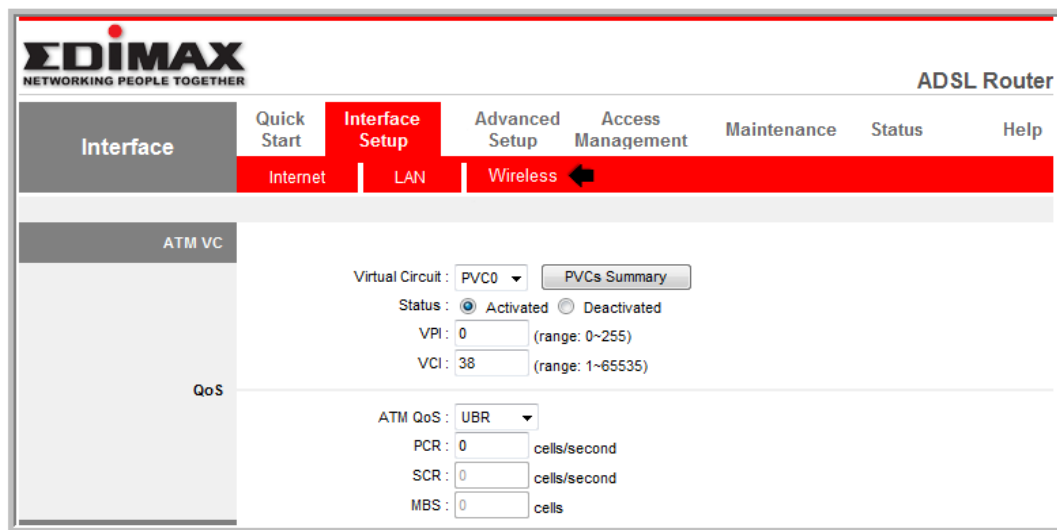

- Select or complete the following in the applicable sections ➔ select **SAVE**:

Access Point Settings:

- **Access Point:** Activated
- **Channel:** Undefined & Number of Channels 11
- **Beacon Interval:** 100
- **RTS/CTS Threshold:** 2347
- **Fragmentation Threshold:** 2346
- **DTM:** 1
- **Band (802.11 b/g):** 802.11b+g [enabling both 802.11b and 802.11g interfaces]

Multiple S SID's Settings:

- **SSID Index:** 1
- **SSID:** This is the G4500's serial number & by which you may identify the device Add: EG4500_[Serial Number]
- **Broadcast SSID:** Yes to Activate the SSID
- **Authentication Type:** WPA-PSK

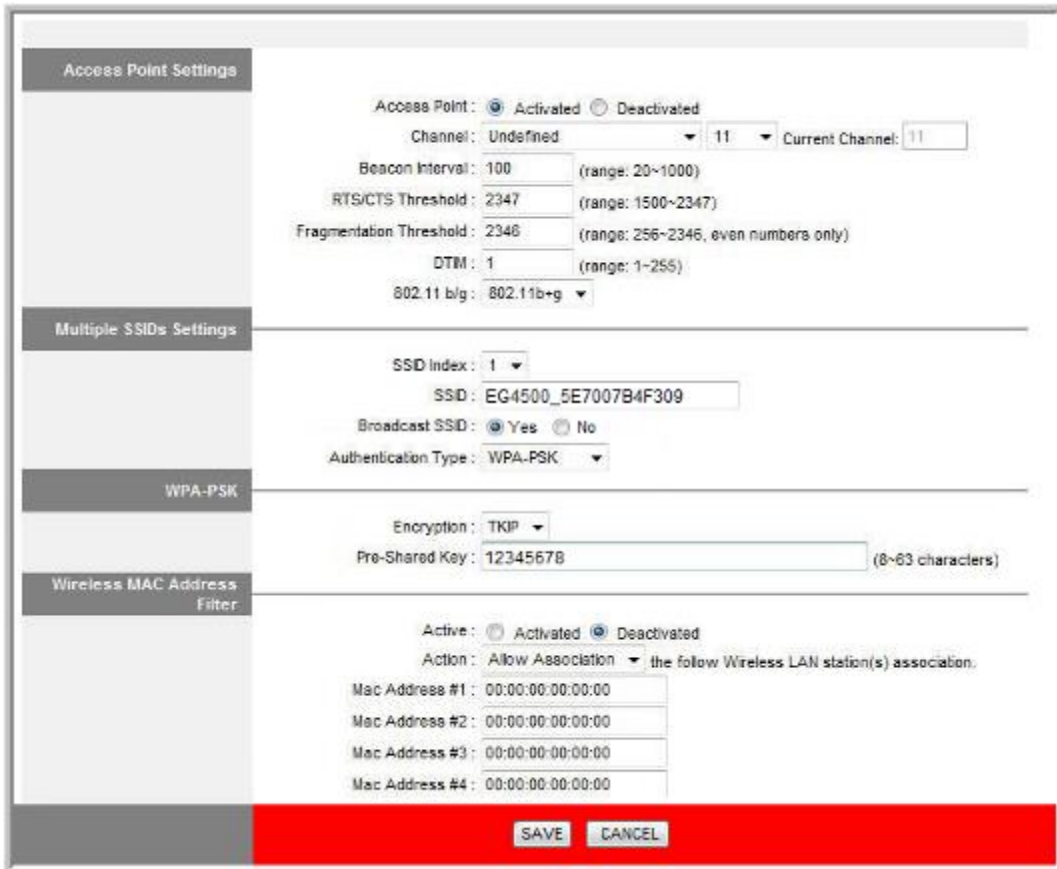

WPA-PSK Settings:

- **Encryption:** TKP
- **Pre-Shared Key:** Enter your password in Pre-Shared Key. This key must be at least 8 characters and no space. This is the key you use to connect to the router wirelessly. eg: 12345678

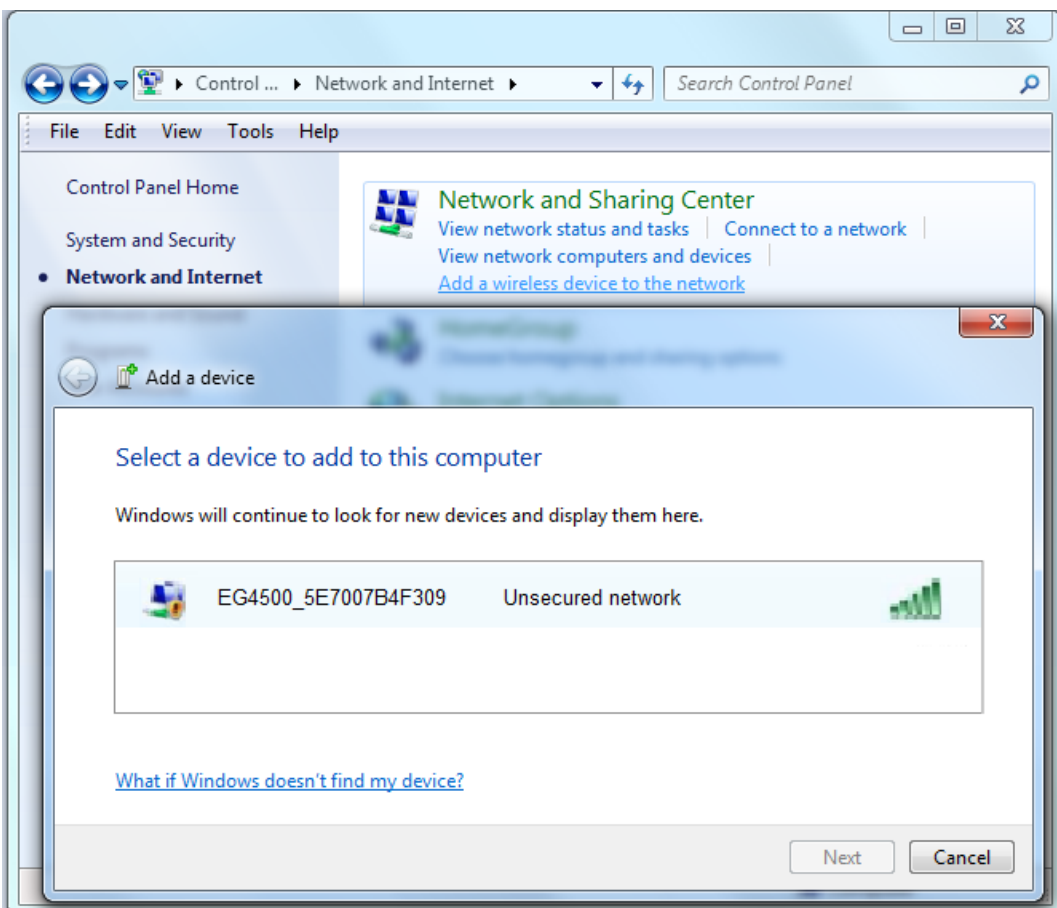

- You should now be able to identify the Router on your computer's Network & Sharing Center:



- If the device remains unconnected you will need to reconnect to the router. Open **Connect to a Network** by clicking the **Network**  or **Wireless** icon in the notification area.
- On the list select the **Router** (identifiable by SSID entered above)  select **Connect**:

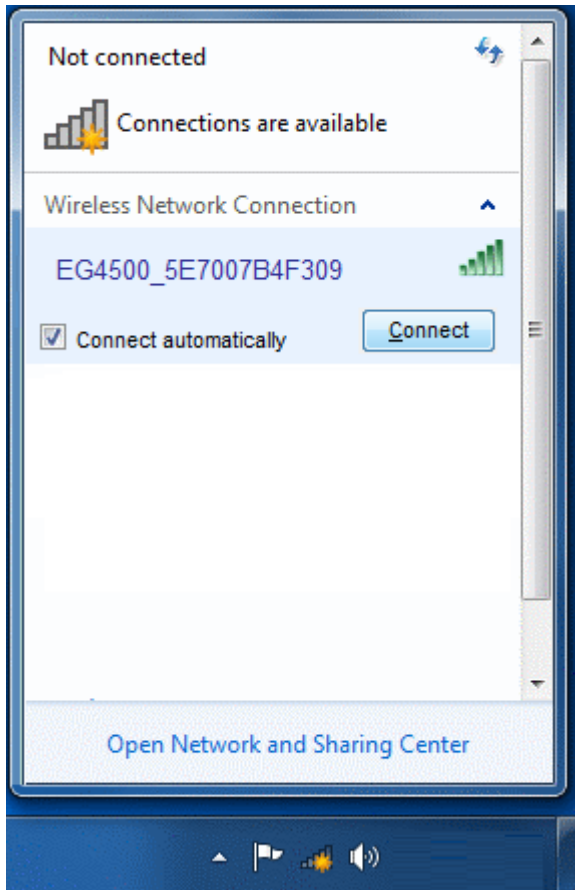

- Enter the **Security Key** (as per the **Pre-Shared Key** entered in the router's **WPA-PSK Settings** above):

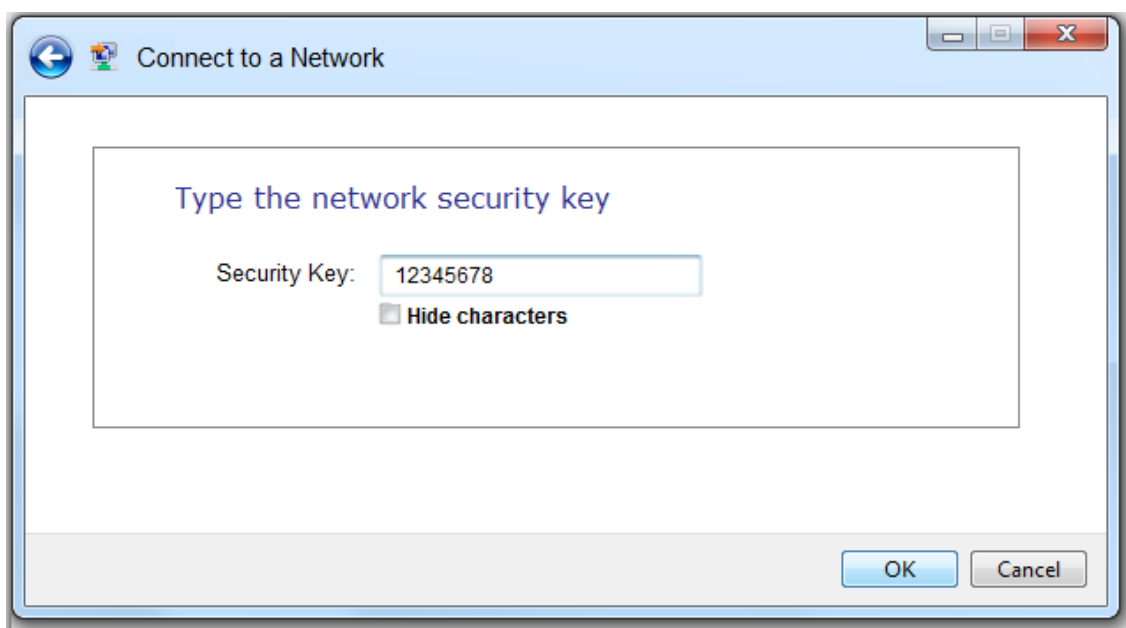

You will now be connected & the [Wi-Fi Activity Indicator](#) will confirm connection (Flashing / Solid Blue): 

SEE ALSO:

- [About Network Setup](#)
- [Wi-Fi Connectivity](#)
- [WAN Internet Accessibility](#)
- [LAN 1](#)
- [LAN 2](#)
- [Outer Access](#)
- [Port Setup](#)
- [Status Summaries](#)
- [About Connecting Communication Ports](#)

WAN Internet Accessibility (G4500 Only)

The WAN port serves to connect the device's internal LAN with other types of networks. It is commonly used to provide internet accessibility over an external Broadband router (Cellular, ADSL or Cable). When connected to an Office network, it most likely already employs a DHCP server. The WAN & LAN 2 Ports are the ideal ports for connecting to the DHCP Server. Do not connect your Portable BLACKBOX to the office network via the LAN 1 port, since an Office DHCP server operation could be interrupted which could lead to severe network malfunctions.

As mentioned previously, each Portable BLACKBOX unit needs to have a fixed IP Address. In each network the available IP numbers differs. The IP Address may be assigned either automatically via the LAN DHCP Server, or manually assigned by the user. Regardless as to what option you choose, prior to assigning the IP address to the unit you will need to consult your IT manager for the network as how to proceed. To connect the device to an additional network, you may do so via the [LAN 2 Port](#).

HOW TO CONFIGURE THE WAN PORT:

- As per the previous step [Access](#) the Network Window & in the **Internal Link Section** you will have two options:

Internal Link	
Auto DHCP	Disable ▾
IP Address	100.100.100.115
Subnet Mask	255.255.254.0

- Auto DHCP Disable** (User Assigned IP Address obtained from the IT Manager) all parameters will be fixed & User-Assigned:
 - Select **Auto DHCP Disable**
 - Enter the **IP Address**
 - An optional **Subnet Mask** (for this port & instrument) is entered as per your IT Manager's instructions
 - Auto DHCP Enabled** allows the LAN DHCP server to assign an IP Address to the unit
 - Select **Auto DHCP Enable**
 - Your G4500 unit's **IP Address** & **Subnet Mask** will now be automatically assigned
- To apply your changes select **Apply Changes** ➔ **Refresh Data** to review your changes
- To enforce your changes to your Portable BLACKBOX select **Restart Unit**

NOTE NOTE NOTE

- WAN & LAN 2 cannot co-exist in the same logical IP subnet, even if only one of them is actively connected to a network. For example: if WAN is configured as 172.17.4.68 with subnet mask of 255.255.0.0, then LAN 2 cannot be configured as 172.17.X.X.
- The PQSCADA will not be able to identify any newly assigned IP Addresses for your Portable BLACKBOX unit. As such, when the PQSCADA will download the PQZIP files from your G4500 unit, it will not automatically associate the new IP with the same database. Therefore, you will need to configure the new IP Address for your Portable BLACKBOX Device in the PQSCADA (In the F1 Help Wizard of the PQSCADA, follow the Components → Nodes → Configuration → Device procedure)

SEE ALSO:

- [About Network Setup](#)
- [Wi-Fi Connectivity](#)
- [LAN 1](#)
- [LAN 2](#)
- [Outer Access](#)
- [Port Setup](#)
- [Status Summaries](#)
- [About Connecting Communication Ports](#)

LAN 1 (G4500 Only)

This port is the main choice for a standalone PC or Laptop connection with the Portable BLACKBOX. Technically, any of the available Ethernet ports can be used for a single PC connection. However, the most recommended is a LAN 1 option due to the integrated DHCP server that is available via the port. Once [Connected](#), a PC will automatically obtain an IP address configuration that will connect it to the G4500's internal WEB/FTP servers as well as to a router management WEB server. Since it is automatic, there is no need to configure the device's IP address. Use this port as an alternative connection if you are unable to make a [Wi-Fi Connection](#).

WARNING

DO NOT CONNECT YOUR PORTABLE BLACKBOX TO THE OFFICE NETWORK VIA THE LAN 1 PORT, SINCE AN OFFICE DHCP SERVER OPERATION COULD BE INTERRUPTED WHICH COULD LEAD TO SEVERE NETWORK MALFUNCTIONS.

SEE ALSO:

- [About Network Setup](#)
- [Wi-Fi Connectivity](#)
- [WAN Internet Accessibility](#)
- [LAN 2](#)
- [Outer Access](#)
- [Port Setup](#)
- [Status Summaries](#)
- [About Connecting Communication Ports](#)

LAN 2

As mentioned previously the communication ports differ between the G4500 & G3500 BLACKBOX. As such, the configuration procedure differs between the two devices:

G4500 LAN 2 CONFIGURATION:

The port is mainly used to connect the device to a LAN network of computers or an additional network other than the [WAN](#) connection. As mentioned previously each Portable BLACKBOX unit needs to have a fixed IP Address & that in each network the available IP numbers differs. The IP Address may be assigned either automatically via the LAN DHCP Server, or manually assigned by the user. As per the [WAN Port](#), regardless as to what option you choose, prior to assigning the IP address to the unit you will need to consult your IT manager for the network as how to proceed. The LAN 2 port is also used for the G4100 LCD Display connection & the configuration procedure is very quick & easy to follow. There is no need to configure the LAN 2 port if you don't want to make another network connection, or if the G4100 LCD Display is absent.

- [Access](#) the Network Window
- If you need to change the default settings, in the **LAN 2 Section** for Auto DHCP select **Disable**:

LAN2/LCD	
Auto DHCP	Enable ▾
IP Address	100.100.100.119
Subnet Mask	255.255.254.0

LAN 2 ADDITIONAL NETWORK CONFIGURATION:

- Enter the **IP Address** of the instrument
- An optional **Subnet Mask** (for this port & instrument) is entered as per your IT Manager's instructions

LAN 2 G4100 LCD DISPLAY CONFIGURATION:

- **IP Address:** Is the IP address for this port on the instrument. It is recommended that you retain the default address of **192.168.168.168** in order to enable the G4100 LCD remote screen viewer's plug-&-play compatibility
- **Sub-Net Mask:** Is the Sub-net mask for this port on the instrument. It is recommended that you retain the default address of **255.255.255.0** in order to enable the G4100 LCD remote screen viewer's plug-&-play compatibility
- The Default settings will automatically appear in this section should no changes be required & the Auto DHCP will remain on **Enable**
- To apply your changes select **Apply Changes** ➔ **Refresh Data** to review your changes

NOTE NOTE NOTE

IMPORTANT: The IP Address & Sub-net for WAN differs from LAN 2's IP Address & Sub-net as they are configured for two different networks. Therefore should you choose to Disable the default settings, ensure the IP Address for the G4100 LCD Display is configured on an additional Network.

- WAN & LAN 2 cannot co-exist in the same logical IP subnet, even if only one of them is actively connected to a network. For example: if LAN 1 is configured as 172.17.4.68 with subnet mask of 255.255.0.0, then LAN 2 cannot be configured as 172.17.X.X.
- The PQSCADA will not be able to identify any newly assigned IP Addresses for your Portable BLACKBOX unit. As such, when the PQSCADA will download the PQZIP files from your G4500 unit, it will not automatically associate the new IP with the same database. Therefore, you will need to configure the new IP Address for your Portable BLACKBOX Device in the PQSCADA (In the F1 Help Wizard of the PQSCADA, follow the Components ➔ Nodes ➔ Configuration ➔ Device procedure)

G3500 LAN 2 CONFIGURATION:

The G3500 Portable BLACKBOX has only one LAN port & this is the main connection port for either the G4150, or DHCP, or PC, or Laptop, or LAN Network of Computers or the G4100 Remote Display Unit. When connected to an Office network, it most likely already employs a DHCP server. As mentioned previously, each Portable BLACKBOX unit needs to have a fixed IP Address. In each network the available IP numbers differs. The IP Address may be assigned either automatically via the LAN DHCP Server, or manually assigned by the user. Regardless as to what option you choose, prior to assigning the IP address to the unit you will need to consult your IT manager for the network as how to proceed. The procedure for connecting the G4100 LCD Display is outlined below.

- [Access](#) the Network Window
- If you need to change the default settings, in the **LAN 2 Section** for Auto DHCP select **Disable**:

LAN2/LCD	
Auto DHCP	Enable ▾
IP Address	100.100.100.119
Subnet Mask	255.255.254.0

LAN 2 General CONFIGURATION:

For DHCP or LAN Network of Computers:

- Enter the **IP Address** of the instrument
- An optional **Subnet Mask** (for this port & instrument) is entered as per your IT Manager's instructions

For the G4150 Mobile Analysis Lab, or PC, or Laptop: Once the device is [Connected](#) to the G3500, the device will automatically obtain an IP address configuration that will connect it to the G3500's internal WEB/FTP servers. Since it is automatic, there is no need to configure the device's IP address.

LAN 2 G4100 LCD DISPLAY CONFIGURATION:

- **IP Address:** Is the IP address for this port on the instrument. It is recommended that you retain the default address of **192.168.168.168** in order to enable the G4100 LCD remote screen viewer's plug-&-play compatibility
- **Sub-Net Mask:** Is the Sub-net mask for this port on the instrument. It is recommended that you retain the default address of **255.255.255.0** in order to enable the G4100 LCD remote screen viewer's plug-&-play compatibility
- The Default settings will automatically appear in this section should no changes be required & the Auto DHCP will remain on **Enable**
- To apply your changes select **Apply Changes** ➔ **Refresh Data** to review your changes

NOTE NOTE NOTE

- The PQSCADA will not be able to identify any newly assigned IP Addresses for your Portable BLACKBOX unit. As such, when the PQSCADA will download the PQZIP files from your G4500 unit, it will not automatically associate the new IP with the same database. Therefore, you will need to configure the new IP Address for your Portable BLACKBOX Device in the PQSCADA (In the F1 Help Wizard of the PQSCADA, follow the Components ➔ Nodes ➔ Configuration ➔ Device procedure)

SEE ALSO:

- [About Network Setup](#)
- [Wi-Fi Connectivity](#)
- [WAN Internet Accessibility](#)
- [LAN 1](#)
- [Outer Access](#)
- [Port Setup](#)
- [Status Summaries](#)
- [About Connecting Communication Ports](#)

Outer Access

In this section you will be able to configure your Portable BLACKBOX for sending data to an IP Address outside its [LAN 1](#) & setting an IP Address for sending Notification E-Mails.

CONFIGURING THE G4K BLACKBOX FOR OUTER ACCESS

- [Access](#) the Network Window
- In the **Outer Access Section** you have the following settings:

Outer Access	
Gateway	<input type="text" value="192.168.1.254"/>
SMTP Server	<input type="text" value="0.0.0.0"/>

- **Gateway:** Is utilized for setting the BLACKBOX'S default Gateway IP addresses in order to send data to an IP addresses outside its [LAN 1](#)
- **SMTP Server:** Is used for setting an IP Address for an E-Mail Server to be used for sending notification E-Mails
- To apply your changes select [Apply Changes](#) ➔ [Refresh Data](#) to review your changes

NOTE NOTE NOTE

Configurations need to be duplicated & configured in Elspec's PQSCADA. (In the F1 Help Wizard of the PQSCADA, follow the **Components** ➔ **Server** ➔ **Configuration** ➔ **E-Mail** procedure).

SEE ALSO:

- [About Network Setup](#)
- [Wi-Fi Connectivity](#)
- [WAN Internet Accessibility](#)
- [LAN 1](#)
- [LAN 2](#)
- [Port Setup](#)
- [Status Summaries](#)
- [About Connecting Communication Ports](#)

Port Setup

Within the Port Setup section, you will be able to configure your Portable BLACKBOX for remote access. In the Port Setup section you can configure the internet port numbers for standard communication protocols (E-Mails, File Transfer & Web Browsing). The primary reasons for utilizing this procedure is for networks where standard port numbers are forbidden or reserved by Firewalls; or it may be used in instances where you would like to reserve the standard port number for a legacy modem/router that does not support port forwarding. Most external modems/routers on the market today do support port forwarding. Elspec recommends retaining the default port addresses setup, in order to simplify & provide straightforward access for web browsers or FTP clients to your G4500/G3500 unit via LAN/Internet.

CONFIGURING PORT NUMBERS FOR STANDARD COMMUNICATION PROTOCOLS

- [Access](#) the Network Window
- In the **Port Setup Section** you have the following settings:

Port Setup	
HTTP Port	<input type="text" value="80"/>
FTP Daemon	<input type="text" value="21"/>
FTP Data	<input type="text" value="20"/>
SMTP Port	<input type="text" value="25"/>

- **HTTP Port:** Utilized for setting the Web Browser's Port Address
- **FTP Daemon:** Utilized for setting the Port Address of File Transfer (Control Channel)
- **FTP Data:** Used for setting the Port Address of File Transfer (Data Channel)
- **SMTP Port:** Used for setting the Port Address of Mail Transfers. The SMTP server should allow anonymous clients. The BLACKBOX doesn't support SMTP authentication.
- To apply your changes select **Apply Changes** ➔ **Refresh Data** to review your changes

NOTE NOTE NOTE

Changes to the FTP Ports also require changes to Elspec's PQSCADA's configuration. (In the **F1 Help Wizard** of the PQSCADA, follow the **Components** ➔ **Nodes** ➔ **Configuration** ➔ **Device** procedure. The FTP Port is added in the PQSCADA as an addition with your Portable BLACKBOX's Device IP in the IP Address field as: 100.100.100.100:20)

SEE ALSO:

- [About Network Setup](#)
- [Wi-Fi Connectivity](#)
- [WAN Internet Accessibility](#)
- [LAN 1](#)
- [LAN 2](#)
- [Outer Access](#)
- [Status Summaries](#)
- [About Connecting Communication Ports](#)

Status Summaries

Within the [Network Window](#) you are able to view two sections that summarize your Portable BLACKBOX's network configurations. The summaries include:

NETWORK INTERFACE:

Network Interface				
Interface	Link	Speed	Duplex	Mode
LAN1 [Link]	On	100 Mbits	Full	100Mbit FD
LAN2 [LCD]	On	100 Mbits	Full	Auto negotiate

- **LAN 1 Status:**
 - **Link:** On (indicates Portable Unit's IP Address is established in your Network) / Off (BLACKBOX Unit's IP Address is not established)
 - **Speed:** Flow control of data transferral speed
 - **Duplex:** Full (using Full Duplex for communication) / Half (using Half Duplex for communication)
 - **Mode:** Auto negotiate means that your Portable BLACKBOX is connected with the Network sever chooses common transmission parameters (Speed, Duplex Mode & Flow Control)
- **LAN 2 G4100 LCD Status:**
 - **Link:** On (indicates your G4100 Unit's IP Address is established in the 2nd Network) / Off (Unit's IP Address is not established / not in use)
 - **Speed:** Flow control of data transferral speed
 - **Duplex:** Full (using Full Duplex for communication) / Half (using Half Duplex for communication)
 - **Mode:** Transmission parameter is set at 10Mbit at Full Duplex (FD) to the 2nd Network's Server

CONNECTIONS:

Connections			
HTTP Active	LCD Active	FTP Active	FTP Max
1	0	0	5

- **HTTP Active:** Connection status of your Portable BLACKBOX Unit & Web Browser as per Port Configuration
- **LCD Active:** Connection status of G4100 as per LAN 2 Configuration to the 2nd Network
- **FTP Active:** Connection status of the File Transfer Control Channel as per Port Configuration
- **FTP Max:** Number of users defined FTP Access
- To apply your changes select [Apply Changes](#) ➔ [Refresh Data](#) to review your changes

SEE ALSO:

- [About Network Setup](#)
- [Wi-Fi Connectivity](#)
- [WAN Internet Accessibility](#)
- [LAN 1](#)
- [LAN 2](#)
- [Outer Access](#)
- [Port Setup](#)
- [About Connecting Communication Ports](#)

Serial Ports

In this section you will be able to configure the serial lines of your Portable BLACKBOX for data link connectivity, including:

- [Setting up the configurations of the RS485/RS422 interface parameters itself](#)
- [Configuring the PPP \(Point-to-Point Protocol\) parameters for serial communication](#)
- [Viewing the status of the PPP](#)
- [Setting up a standard AT commands modem](#)

OPEN THE SERIAL PORTS WINDOW

- [Access](#) the Portable BLACKBOX's Configuration via **Espec's Web Interface** ➔ log on as the **Administrator** ➔ select the **Configuration Tab**
- Under **Communication** select the **Serial Ports Tab**:

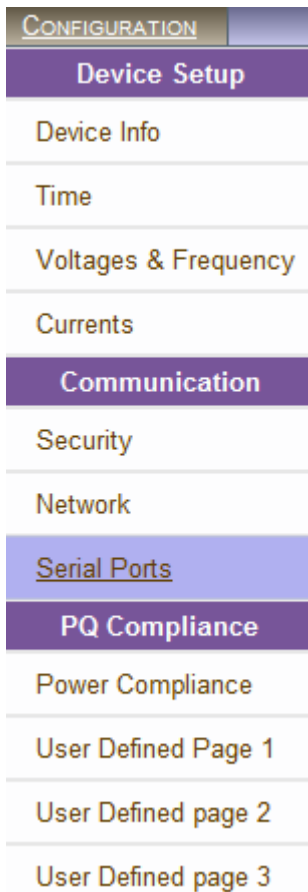

- The Serial Ports Window will now open:

RW ■ CONFIGURATION » SERIAL PORTS

Apply Changes
Refresh Data
Connect
Disconnect
Reset modem

RS-485 / RS-422

Bitrate	Data Bits	Parity	Stop Bits
19200 ▾	8 bit	None	1
Serial Mode		ModBus Slave Address	
TTY ▾		159 ▾	

PPP Status ☑ [Message Log]

PPP IP	PPP Subnet	Signal Quality
N/A	N/A	-----

Message Log

Empty

PPP Configuration

PAP Status	CHAP Status	Username	Password	PoE Auto reset
Enable ▾	Enable ▾	<input type="text"/>	<input type="text"/>	Disable ▾

Modem Configuration

Init String <input type="text"/>	Reset String <input type="text"/>
Default Init <input type="text"/>	Phone Number <input type="text"/>

NOTE NOTE NOTE

If you are not logged on as the Administrator, you will not be able to change any of these settings & you will receive the following error message in your attempt to do so:

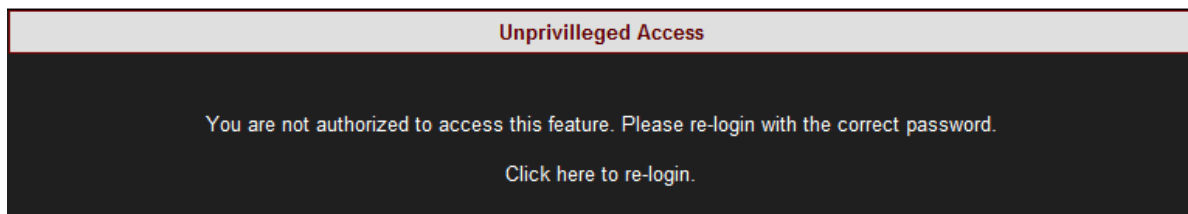

SEE ALSO:

- [About BLACKBOX's Communication Configuration](#)
- [Security](#)
- [Network](#)
- [About Connecting Communication Ports](#)

RS-485 / RS-422

The setup configures the parameters of RS-485/RS-422 serial interface.

HOW TO CONFIGURE RS-485 / RS-422 SERIAL INTERFACE

- As per the previous step [Access](#) the **Serial Ports Window** & in the **RS-485/RS-422 Section** complete the applicable **Parameters**:

RS-485 / RS-422			
Bitrate	Data Bits	Parity	Stop Bits
19200 ▾	8 bit	None	1
Serial Mode		ModBus Slave Address	
TTY ▾		159 ▲▼	

- Bit rate:** With the ▼ adjust the transfer rate for data
- Data Bits:** (For information only) Indicates the number of data bits in a byte
- Parity:** (For information only) Parity code indicating error detection (Movement of digital data from one location to another)
- Stop Bits:** (For information only) Number of stop bits used to mark the end of a byte transmission
- Serial Mode:** With the ▲ select configuration from available **Options**:
 - TTY:** Debug shell mode for PPP stream
 - Elcom :** Elspec communication for connecting to the Equalizer
 - MODBUS RTU:** MODBUS protocol (serving as a slave on a Modbus network)
 - GPS:** For GPS attachment to this serial port
 - PPP:** Connection for PPP communication through this serial port
- MODBUS Slave Address:** Unique ID of the BLACKBOX on a Modbus network
- For your changes to be taken into effect select **Apply Changes** ➡ **Refresh Data** to review your changes
- In order to establish connection as per the setup configurations select **Connect**
- In order to discontinue the connection select **Disconnect**

SEE ALSO:

- [About Serial Ports](#)
- [RS-485/ RS-422](#)
- [PPP Configuration](#)
- [PPP Status](#)
- [Modem Configuration](#)
- [About Connecting Communication Ports](#)

PPP Configuration

In this section you will be able to configure PPP (Point-to-Point Protocol) parameters for serial communication.

HOW TO CONFIGURE PPP PARAMETERS

- [Access](#) the Serial Ports Window & in the PPP Configuration Section complete the applicable Parameters:

PPP Configuration				
PAP Status	CHAP Status	Username	Password	PoE Auto reset
Enable ▾	Enable ▾	<input type="text"/>	<input type="text"/>	Disable ▾

- **PAP Status:** With the ▾ Enable/Disable the PAP (Password Authentication Protocol) feature
- **CHAP Status:** Enable/Disable CHAP (Challenge Handshake Authentication Protocol) feature
- **Username:** This is the Username that you receive from your ISP (Internet Service Provider)
- **Password:** This is the Password that you receive from your ISP
- For your changes to be taken into effect select **Apply Changes** ➔ **Refresh Data** to review your changes
- In order to establish connection as per the setup configurations select **Connect**
- In order to discontinue the connection select **Disconnect**

SEE ALSO:

- [About Serial Ports](#)
- [RS-485/ RS-422](#)
- [PPP Status](#)
- [Modem Configuration](#)
- [About Connecting Communication Ports](#)

PPP Status

This indicates the status of the PPP with a Log.

HOW TO VIEW PPP STATUS

- [Access](#) the **Serial Ports Window** & in the **PPP Status** section **Select/Deselect** the **Message Log** with . This will Enable/Disable the logging of this protocol's activity in the log:

PPP Status <input checked="" type="checkbox"/> [Message Log]		
PPP IP	PPP Subnet	Signal Quality
N/A	N/A	-----
Message Log		
Empty		

- For your changes to be taken into effect select **Apply Changes** ➔ **Refresh Data** to review your changes
- In order to establish connection as per the setup configurations select **Connect**
- In order to discontinue the connection select **Disconnect**

SEE ALSO:

- [About Serial Ports](#)
- [RS-485/ RS-422](#)
- [PPP Configuration](#)
- [Modem Configuration](#)
- [About Connecting Communication Ports](#)

Modem Configuration

The following strings require setup when working with a standard AT commands modem.

HOW TO CONFIGURE THE MODEM SETUP

- [Access](#) the Serial Ports Window & in the **Modem Configuration Section** complete the applicable Parameters:

Modem Configuration			
Init String	<input type="text"/>	Reset String	<input type="text"/>
Default Init	<input type="text"/>	Phone Number	<input type="text"/>

- **Init String:** AT command string to initialize the modem
- **Reset String:** AT command string to reset the modem
- **Default Init:** AT command string to set the modem to default configuration
- **Phone Number:** Dial up number (without any gaps/hyphenation marks)
- To apply your changes select **Apply Changes** ➔ **Refresh Data** to review your changes
- In order to connect the modem as per the setup configurations select **Connect**
- In order to disconnect the modem select **Disconnect**

SEE ALSO:

- [About Serial Ports](#)
- [RS-485/ RS-422](#)
- [PPP Configuration](#)
- [PPP Status](#)
- [About Connecting Communication Ports](#)

About Power Quality Compliance

The BLACKBOX device series provides PQ Parameters according to EN50160 & IEC61000-4-30, including other National Standards. In this window you will be able to:

- [Select the specific compliance standard to be evaluated by the unit's internal compliance engine](#)
- [Customize parameters to comply with any other unique standards or requirements](#)

ACCESS THE PORTABLE BLACKBOX'S POWER QUALITY COMPLIANCE WINDOW

- [Access](#) the Portable BLACKBOX's via Elspec's Web Interface ➡ log on as the Administrator
➡ select the **Configuration Tab**
- All the PQ compliance configurations (including the user-defined pages) are located under the **PQ Compliance Tab**:

CONFIGURATION
Device Setup
Device Info
Time
Voltages & Frequency
Currents
Communication
Security
Network
Serial Ports
PQ Compliance
<u>Power Compliance</u>
User Defined Page 1
User Defined page 2
User Defined page 3

Power Quality Compliance Configuration

The Portable BLACKBOX contains a power quality compliance engine that enables real-time evaluation of power quality according to a number of standards, such as:

- EN50160
- EN50160 Asynchronous Torque
- NVE-PQ (Norway)
- NVE (Islands)
- CREG (Colombia)
- AER (Queensland - Australia)

On this page you will be able to select the specific compliance standard to be evaluated by your Portable unit's internal compliance engine.

- [Access](#) the Portable BLACKBOX unit via Elspec's Web Interface ➔ log on as the Administrator ➔ select Configuration ➔ PQ Compliance ➔ Power Compliance. The Power Compliance window will now open:

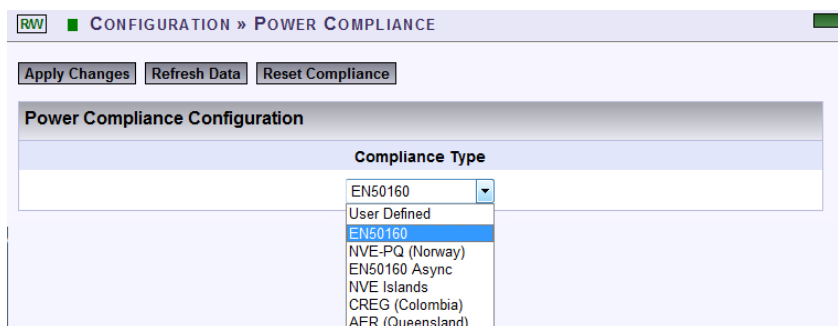

- From the drop down selection ▼ select the Applicable Compliance Standard
- Select **Apply Changes** & the following Message Box will appear in order to Restart the Compliance Evaluations by the BLACKBOX:

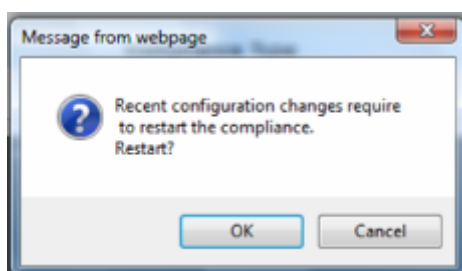

- Select **OK** & you will receive the following Success Message:

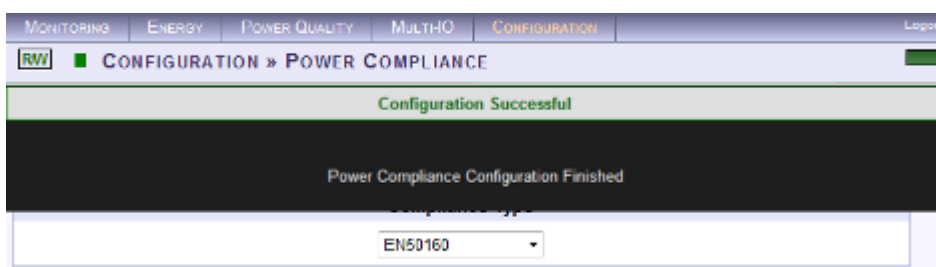

- Select **Refresh Data** to review your changes

NOTE NOTE NOTE

If you are not logged on as the Administrator, you will not be able to change any of these settings & you will receive the following error message in your attempt to do so:

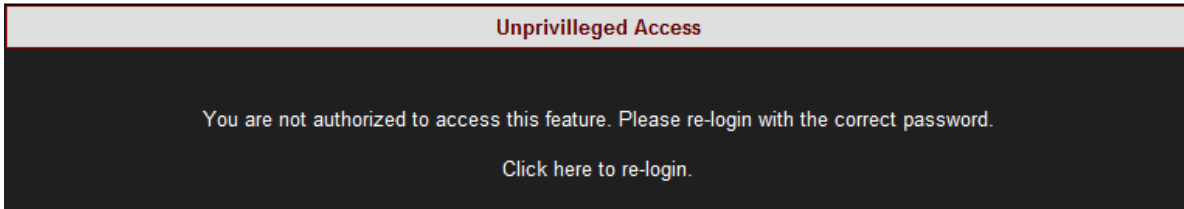

SEE ALSO:

- [About PQ Compliance](#)
- [User Defined Pages](#)
- [About PQ Monitoring](#)

User Custom Compliance - User Defined Pages

In addition to real-time evaluations for a number of [Power Quality Compliance](#) standards, the Portable BLACKBOX's built-in PQ engine supports a user-compliance mode in which all compliance parameters can be self-edited & modified. This self-editing & modification allows the user to set parameters meet unique conditions, rules, measurement intervals at different observation periods. The windows consist of:

- [User Defined Page 1](#) - Which encompasses: Voltage Frequencies, Voltage Dips Supply, Long Interruptions & Temporary Overvoltage (Swells)
- [User Defined Page 2](#) - Which encompasses: Voltage Variations, Rapid Voltage Changes, Unbalanced Voltage & Voltage Flickering
- [User Defined Page 3](#) - Which encompasses: Voltage Harmonics (Including individual Harmonics)

OPEN & ACTIVATE THE USER DEFINED PAGES:

- [Access](#) the Portable BLACKBOX unit via [Elspec's Web Interface](#) → log on as the Administrator → select **Configuration Tab** → **PQ Compliance Tab**
- In the **Power Compliance** window select **User Defined**:

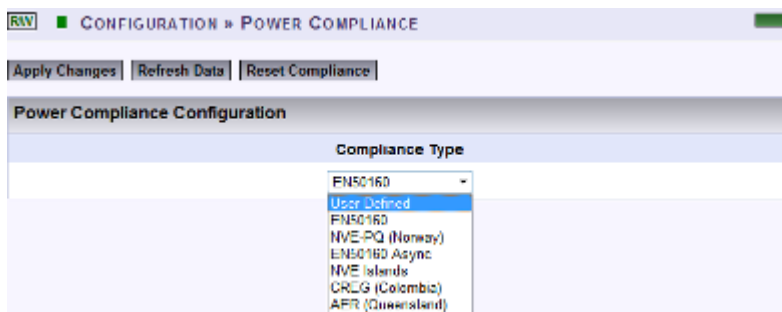

- Select **Apply Changes** & the following Message Box will appear in order to **Restart the Compliance Evaluations by the Portable BLACKBOX**:

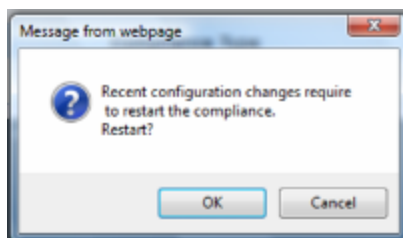

- Select **OK** & you will receive the following Success Message:

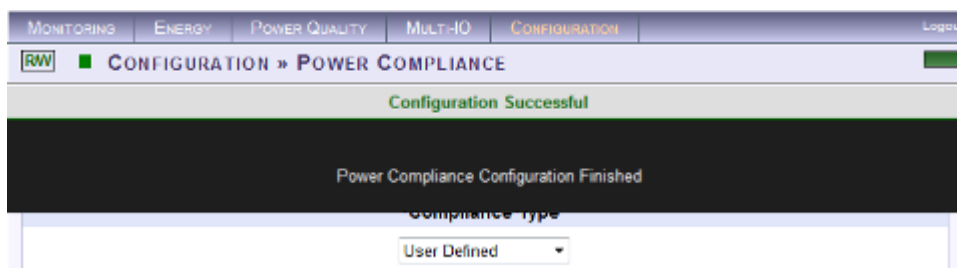

- Select **Refresh Data** to review your changes

NOTE NOTE NOTE

If you are not logged on as the Administrator, you will not be able to change any of these settings & you will receive the following error message in your attempt to do so:

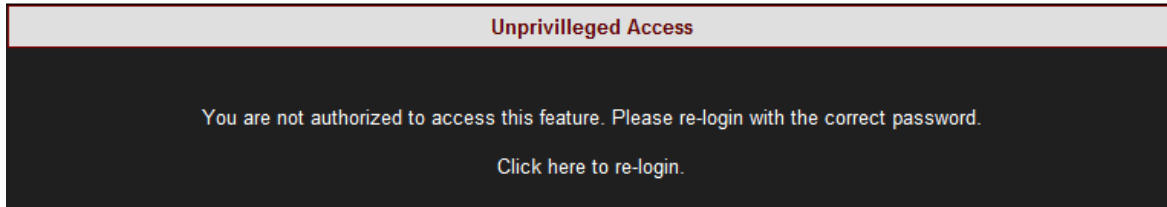

SEE ALSO:

- [About PQ Compliance](#)
- [PQ Compliance Configuration](#)
- [About PQ Monitoring](#)

User Defined Page 1

In this window you will be able to edit & modify a number of compliance parameters thereby enabling your Portable BLACKBOX's built-in engine to perform real-time evaluations that will meet unique [Power Quality Compliance](#) standards.

- After you have set the [PQ Compliance to Evaluate User Defined Parameters](#), open **PQ Compliance** ➔ **User Defined Page 1**:

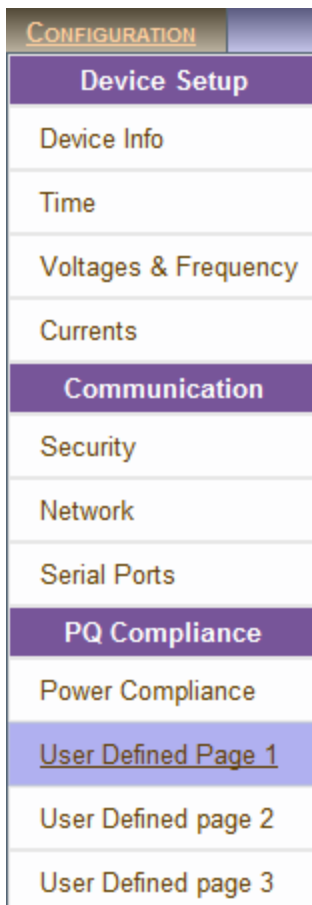

- Collapse / Expand with in order to edit & modify compliance parameters for each of the following sections:

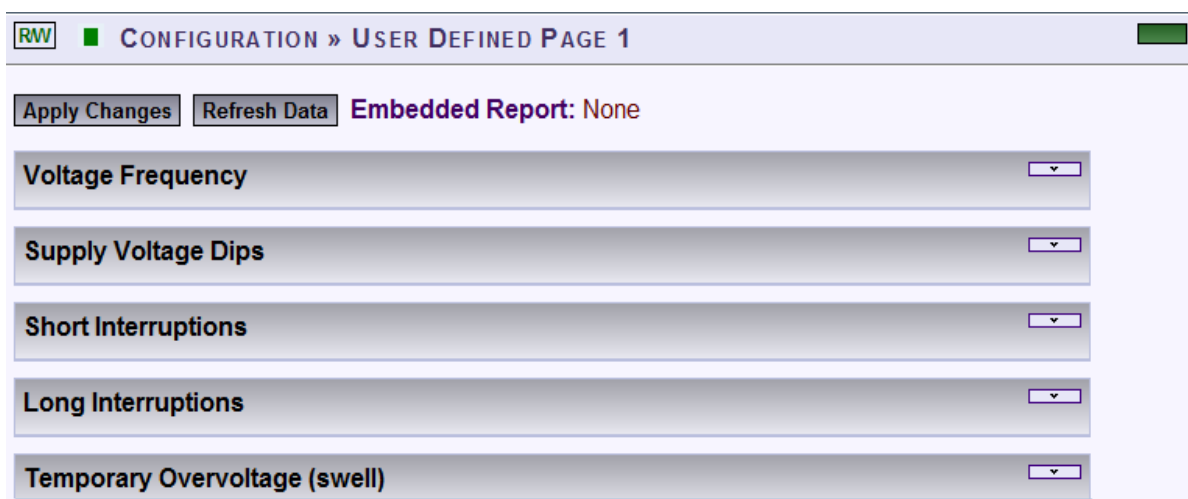

VOLTAGE FREQUENCIES:

Voltage Frequency ▲

Enable check only inside limits of $V_{nom} +$ and $V_{nom} +$ (0 - no limit)

Threshold 1: Detect event if $F > F_{nom} +$ or $F < F_{nom} -$

Compliance Condition 1: Frequency must be valid for at least of time.

Threshold 2: Detect event if $F > F_{nom} +$ or $F < F_{nom} -$
(critical)

Compliance Condition 2: Frequency must be valid for at least of time.

Detection Interval: **Observation Window:**

Ignore Flagged intervals (due to dips/swells) and do not generate events:

Ignore Flagged intervals (due to volt interruption) and do not generate events:

- Frequency compliance is based on statistics: N, N1 & N2. Frequency measurement interval is 10 sec in an entire observation window of 1 week. N - amount of intervals. N1 - intervals frequency exceeded [+1.00%, -1.00%] from nominal freq. N2 - intervals frequency exceeded [+4.00%, -6.00%] from nominal freq. N1 & N2 increment only if valid voltage inside nominal boundary of [+15.0%, -15.0%]. Compliance if both $N1/N < 5.0\%$ of time and $N2 = 0$ of time. Intervals with voltage interruption are discarded. Intervals with DIPS or OVER voltage are discarded.

SUPPLY VOLTAGE DIPS:

Supply Voltage Dips ▲

Dip Depth Threshold: Detect event if $V < V_{nom} -$

Manual deactivation Hysteresis+

Max Depth Threshold: Stop detection if $V < V_{Nom} -$

Max allowed dip duration:

Compliance Condition: Allowed number of dips per observation window:

Record events separately for each of 3 phases:

Voltage events reference type:

Detection Interval: **Observation Window:**

- DIP is a voltage drop of more than 10.0% from Nominal (but no more than 100.0%, and deactivate on 8.0%) DIP min time is 10 ms and max time of 1 min. DIP events are counted per all phases combined within observation window of 1 week. Total events (N) allowed is: 20.

SHORT INTERRUPTIONS:

Short Interruptions

Detection threshold: $V < V_{nom} -$

One phase drop is enough to trigger event (if not checked, all phases must go down to trigger event)

Manual deactivation Hysteresis+

Max allowed short interruption duration: ▾

Compliance Condition: Max allowed number of short interruptions per observation window:

Detection Interval: ▾ Observation Window: ▾

- Short interruption is a voltage drop of less than 97.0% from nominal (event deactivate on 77.6%). Min duration 10 ms, Max duration 3 min. events are counted in the entire observation window of 1 week. Total events (N) allowed is: 2.

LONG INTERRUPTIONS:

Long Interruptions

Detect threshold is same as for short interruptions.

Detect when duration is larger than the maximum allowed for short interruptions

Allowed number of long interruptions per observation window:

Detection Interval: ▾ Observation Window: ▾

- Long interruptions are the same as short ones but with a longer duration (longer than short interruption maximum time). Long interruptions events are counted within observation window of 1 week. Total events (N) allowed is: 1.

TEMPORARY OVER VOLTAGE (SWELLS):

Temporary Overvoltage (swell)

Detection threshold: $V > V_{Nom} +$

Manual deactivation Hysteresis-

Detect up to level of: $V_{Nom} +$

Compliance Condition: Max allowed number of overvoltages per observation window:

Record events separately for each of 3 phases: ▾

Voltage events reference type: ▾

Detection Interval: ▾ Observation Window: ▾

- Over-voltage events are characterized with RMS voltage higher than 10.0% above Nominal (event deactivate on 8.0%). Min over-voltage event duration is 10 ms, events are counted per all phases combined within observation window of 1 week. No specific events count limitation defined.
- After you have made your selection, select **Apply Changes** & the following Message Box will appear in order to **Restart the Compliance Evaluations by the G4K**:

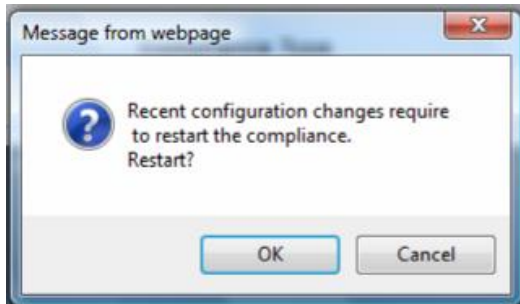

- Select **OK** & you will receive the following Success Message:

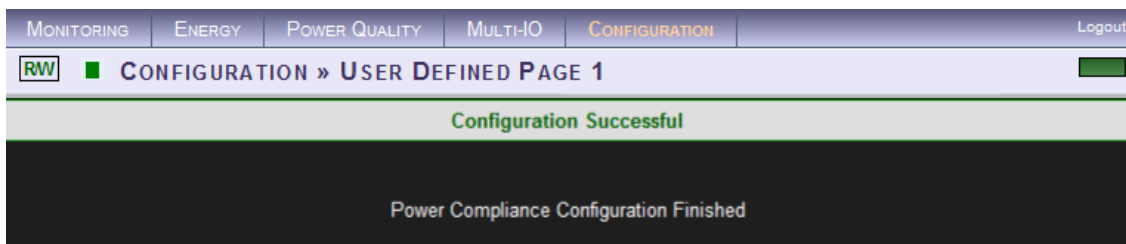

- Select **Refresh Data** to review your changes

NOTE NOTE NOTE

If you are not logged on as the Administrator, you will not be able to change any of these settings & you will receive the following error message in your attempt to do so:

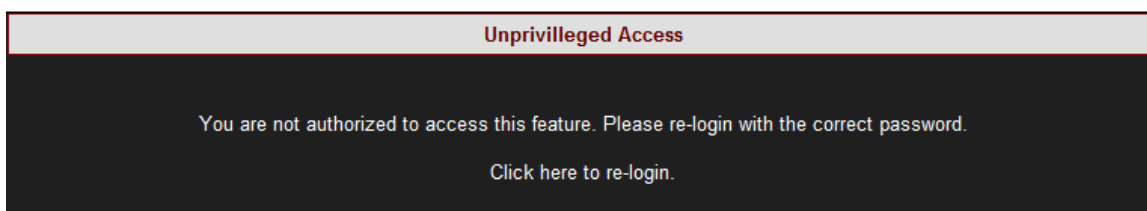

SEE ALSO:

- [About PQ Compliance](#)
- [PQ Compliance Configuration](#)
- [User Defined Pages](#)
- [User Defined Page 2](#)
- [User Defined Page 3](#)
- [About PQ Monitoring](#)

User Defined Page 2

In this window you will be able to edit & modify a number of compliance parameters thereby enabling your Portable BLACKBOX's built-in engine to perform real-time evaluations that will meet unique [Power Quality Compliance](#) standards.

- After you have set the [PQ Compliance to Evaluate User Defined Parameters](#), open **PQ Compliance** ➔ **User Defined Page 2**:

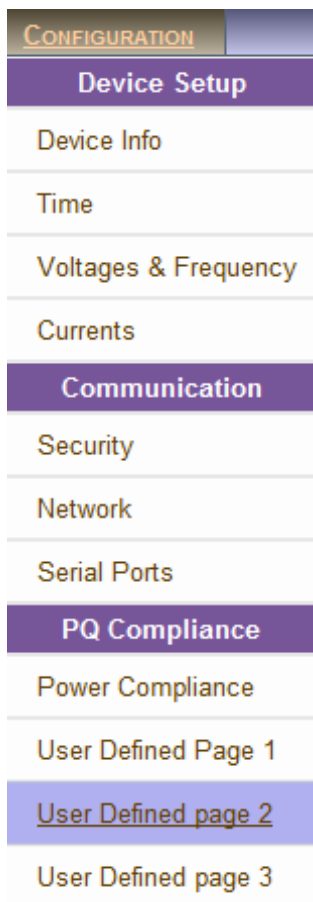

- Collapse / Expand with in order to edit & modify compliance parameters for each of the following sections:

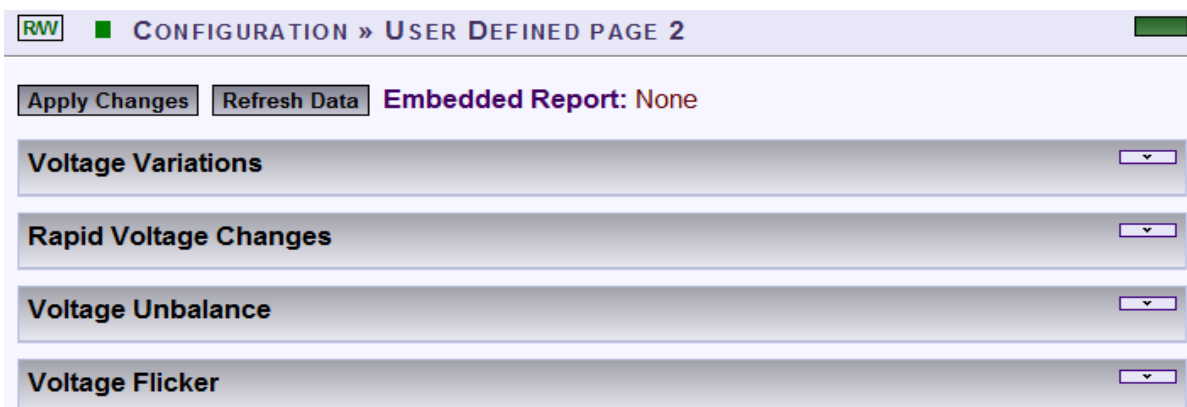

VOLTAGE VARIATIONS:

Voltage Variations	
Threshold 1:	Detect event if $V < V_{nom} + 10\%$ or $V < V_{nom} - 10\%$
Compliance Condition 1:	Voltage must be valid for at least 95% of time.
Threshold 2: (critical)	Detect event if $V < V_{nom} + 15\%$ or $V < V_{nom} - 15\%$
Compliance Condition 2:	Must be valid all time.
Enable entire observation window condition	No
Compliance Condition:	Voltage mean of entire observation window must be within $V_{nom} + 0\%$ and $V_{nom} - 0\%$
Detection Interval:	10 Min.
Observation Window:	1 Week
Ignore Flagged intervals (due to volt interruption) and do not generate events:	Yes
Ignore Flagged intervals (due to dips/swells) and do not generate events:	Yes

- Variations are evaluated by collecting statistics: N, N1 & N2. Statistics are collected as average voltage within intervals of 10 min in observation window of 1 week. N - amount of intervals. N1 - intervals voltage exceeded [+10.0%, -10.0%] boundary of nominal. N2 - intervals voltage exceeded [+15.0%, -15.0%] boundary of nominal. Compliance if $N/N1 \geq 95.0\%$ during the entire observation window. Intervals with voltage interruption are discarded. Intervals with DIPS or OVER Voltage are discarded.

RAPID VOLTAGE CHANGES:

Rapid Voltage Changes	
Enable check only inside limits of $V < V_{nom} \pm 10\%$ (0 - no limit)	
Compliance Condition 1:	Event of $dV > 5\%$ allowed up to 65536 occurrences.
Compliance Condition 2:	Event of $dV > 0\%$ allowed up to 0 occurrences.
Compliance Condition 3:	Event of $dV > 0\%$ allowed up to 0 occurrences.
Compliance Condition 4:	Event of $dV > 0\%$ allowed up to 0 occurrences.
Detection Interval:	3 Sec.
Observation Window:	1 Week

- Rapid voltage change is based on a 3 Sec window in which RMS voltage min and max values are obtained (min,max values should be within +/-10.0% from nominal). The rapid change is the percent of delta between min and max divided by average RMS of 9 Sec. The Rapid percent results are evaluated during observation window of 1 week. Rapid changes are limited to specific count (N): Rapids of more 5.00% allowed: $N \leq 65536$ occurrences.

VOLTAGE UNBALANCE:

Voltage Unbalance

Enable check only inside limits of $V < V_{nom} + 15\%$ and $V_{nom} - 15\%$ (0 - no limit)

Threshold 1: Detect event if $V_{unbal} > 2\%$ (0 - no detection)

Compliance Condition: V_{unbal} must be kept under the detection limit at least 95% of time.

Detection Interval: 10 Min. Observation Window: 1 Week

Additional Interval2: 1 Sec. Threshold 2: $V_{unbal} > 0\%$ (0 - no detection)

Additional Interval3: 1 Sec. Threshold 3: $V_{unbal} > 0\%$ (0 - no detection)

Additional Interval4: 1 Sec. Threshold 4: $V_{unbal} > 0\%$ (0 - no detection)

Ignore Flagged intervals (due to volt interruption) and do not generate events: Yes

Ignore Flagged intervals (due to dips/swells) and do not generate events: Yes

- Voltage unbalance is evaluated at intervals of 10 min within observation window of 1 week. Evaluation is only at intervals in which voltage is inside nominal boundary of [+15.0%,-15.0%]. Unbalance limit N1 is set to 2.00% and must be kept 95.0% of observation time. Intervals with voltage interruption are discarded. Intervals with DIPS or Over voltage are discarded.

VOLTAGE FLICKER:

Voltage Flicker

PST (10 min) Threshold: Detect event if $PST > 0$ (0 - no detection)

PLT (2 hour) Threshold: Detect event if $PLT > 1$ (0 - no detection)

PLT (2 hour) Condition: PLT limits are kept for at least 95% of time.

Detection Interval: 10 Min. Observation Window: 1 Week

Ignore Flagged intervals (due to volt interruption) and do not generate events: Yes

Ignore Flagged intervals (due to dips/swells) and do not generate events: Yes

- Flicker severity is evaluated within observation window of 1 week. During interruption Flicker interval is discarded. During DIPS or Over voltage Flicker Interval is discarded. Plt (2 hours) must be equal or under 1.0 during 95.0% of observation time.
- After you have made your selection, select **Apply Changes** & the following Message Box will appear in order to **Restart the Compliance Evaluations by the G4K**:

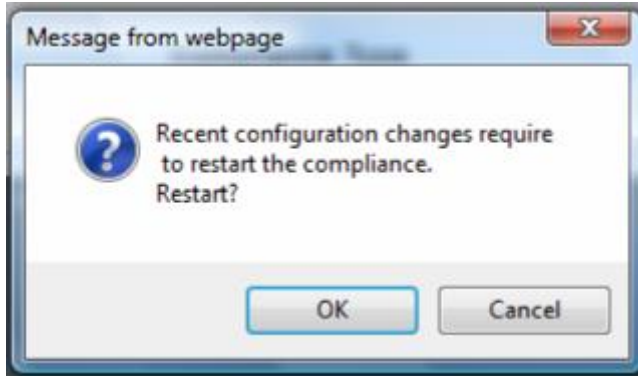

- Select **OK** & you will receive the following Success Message:

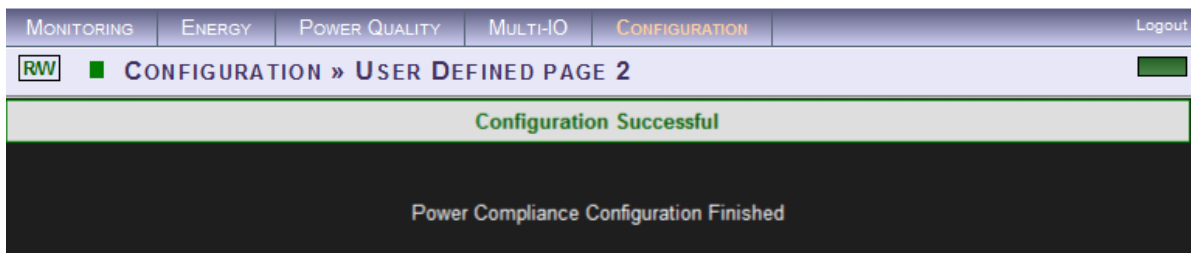

- Select **Refresh Data** to review your changes

NOTE NOTE NOTE

If you are not logged on as the Administrator, you will not be able to change any of these settings & you will receive the following error message in your attempt to do so:

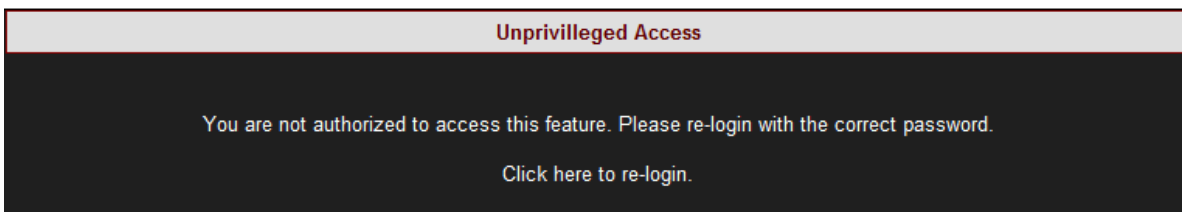

SEE ALSO:

- [About PQ Compliance](#)
- [PQ Compliance Configuration](#)
- [User Defined Pages](#)
- [User Defined Page 1](#)
- [User Defined Page 3](#)
- [About PQ Monitoring](#)

User Defined Page 3

In this window you will be able to edit & modify a number of compliance parameters thereby enabling your Portable BLACKBOX's built-in engine to perform real-time evaluations that will meet unique Power Quality Compliance standards.

- After you have set the PQ Compliance to Evaluate User Defined Parameters, open **PQ Compliance** ➔ **User Defined Page 3**:

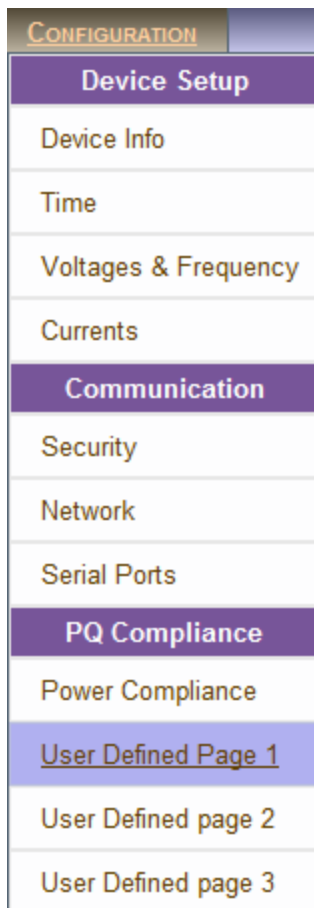

- Collapse / Expand with in order to edit & modify compliance parameters for each of the following sections:

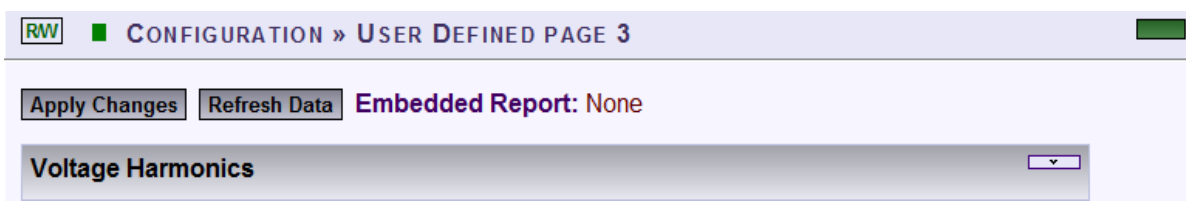

VOLTAGE HARMONICS:

Voltage Harmonics ▲

Enable check only inside limits of $V < V_{nom} + 15\%$ and $V_{nom} - 15\%$ (0 - no limit)

Threshold: THD > % (0 - no detection)
 Individual harmonic limits are specified in the table below

Compliance Condition 1: THD and harmonics are below specified limits
 for at least % of time.

Compliance Condition 2: THD over entire observation
 window must be less than % (0 - no detection)

Detection Interval: Observation Window:

Ignore Flagged intervals (due to volt interruption) and do not generate events:

Ignore Flagged intervals (due to dips/swells) and do not generate events:

- Harmonics evaluated at intervals of 10 min within observation window of 1 week. Evaluation at intervals in which voltage is inside nominal boundary of [+15.0%, -15.0%]. Discarding Intervals with VOLT-INT. Discarding Intervals with DIPS or OVER-VOLT. Individual Harm is limited according to the following table: $H_2 \leq 2.0\%$, $H_3 \leq 5.0\%$, $H_4 \leq 1.0\%$, $H_5 \leq 6.0\%$, $H_6 \leq 0.5\%$, $H_7 \leq 5.0\%$, $H_8 \leq 0.5\%$, $H_9 \leq 1.5\%$, $H_{10} \leq 0.5\%$, $H_{11} \leq 3.5\%$, $H_{12} \leq 0.5\%$, $H_{13} \leq 3.0\%$, ... THD limit is set 8.0% (N2). THD and Harms limits shall be kept at least 95.0% of time.

VOLTAGE HARMONIC LIMITS:

Individual Harmonic Limits:				
	$H_2 < \text{2}\%$	$H_3 < \text{5}\%$	$H_4 < \text{1}\%$	$H_5 < \text{6}\%$
$H_6 < \text{0.5}\%$	$H_7 < \text{5}\%$	$H_8 < \text{0.5}\%$	$H_9 < \text{1.5}\%$	$H_{10} < \text{0.5}\%$
$H_{11} < \text{3.5}\%$	$H_{12} < \text{0.5}\%$	$H_{13} < \text{3}\%$	$H_{14} < \text{0.5}\%$	$H_{15} < \text{0.5}\%$
$H_{16} < \text{0.5}\%$	$H_{17} < \text{2}\%$	$H_{18} < \text{0.5}\%$	$H_{19} < \text{1.5}\%$	$H_{20} < \text{0.5}\%$
$H_{21} < \text{0.5}\%$	$H_{22} < \text{0.5}\%$	$H_{23} < \text{1.5}\%$	$H_{24} < \text{0.5}\%$	$H_{25} < \text{1.5}\%$
$H_{26} < \text{0.5}\%$	$H_{27} < \text{0.5}\%$	$H_{28} < \text{0.5}\%$	$H_{29} < \text{1}\%$	$H_{30} < \text{0.5}\%$
$H_{31} < \text{1}\%$	$H_{32} < \text{0.5}\%$	$H_{33} < \text{0.5}\%$	$H_{34} < \text{0.5}\%$	$H_{35} < \text{1}\%$
$H_{36} < \text{0.5}\%$	$H_{37} < \text{1}\%$	$H_{38} < \text{0.5}\%$	$H_{39} < \text{0.5}\%$	$H_{40} < \text{0.5}\%$

- After you have made your selection, select **Apply Changes** & the following Message Box will appear in order to **Restart the Compliance Evaluations by the G4K**:

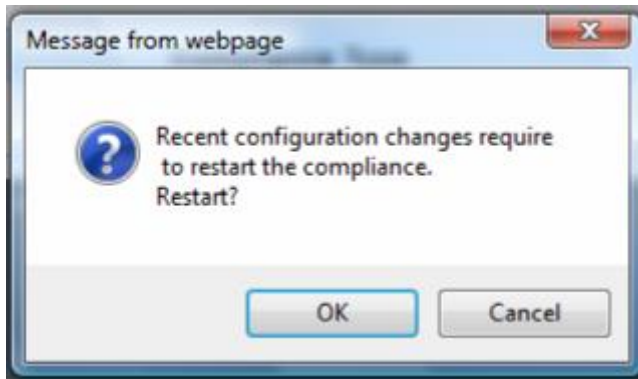

- Select  & you will receive the following Success Message:

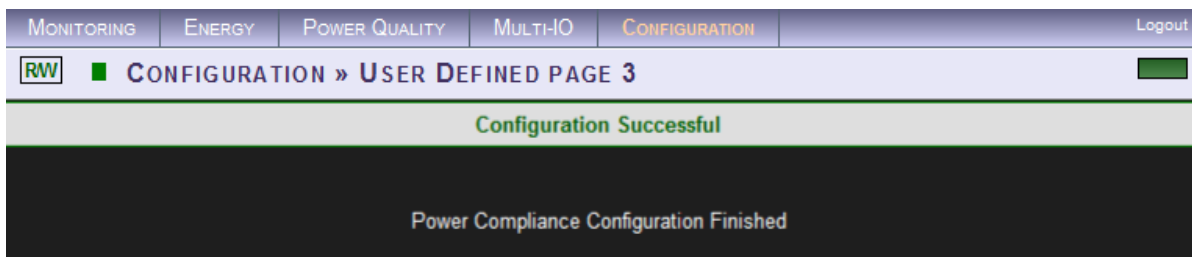

- Select  to review your changes

NOTE NOTE NOTE

If you are not logged on as the Administrator, you will not be able to change any of these settings & you will receive the following error message in your attempt to do so:

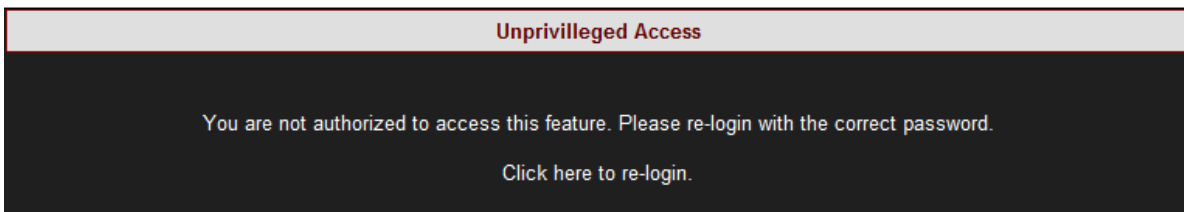

SEE ALSO:

- [About PQ Compliance](#)
- [PQ Compliance Configuration](#)
- [User Defined Pages](#)
- [User Defined Page 1](#)
- [User Defined Page 2](#)
- [About PQ Monitoring](#)

About Advanced Settings

Within the **Advanced Tab** you may configure the Portable BLACKBOX device series' unique capabilities. These capabilities include:

- [View & Copy the System Log](#)
- [Configure your GPS](#)
- [Create Custom Events](#)
- [Configure & Send E-Mail Alerts](#)
- [Produce Energy & Parameter Logs for Reporting](#)
- [Configure the Energy Meter](#)
- [Customize Display in Display Setup](#)
- [Upgrade your G3500/G4500's Software](#)

OPEN THE ADVANCED TAB

- [Access](#) the Portable BLACKBOX unit via **Elspec's Web Interface** → log on as the **Administrator** → select the **Configuration Tab**
- All the advanced settings are located under the **Advanced Tab**:

CONFIGURATION	
Device Setup	Advanced
Device Info	System Log
Time	Custom Events
Voltages & Frequency	PQZIP Recording
Currents	E-mail Alerts
Communication	Reports
Security	Energy Meter
Network	Display Setup
Serial Ports	Firmware Upgrade
PQ Compliance	
Power Compliance	
User Defined Page 1	
User Defined page 2	
User Defined page 3	

NOTE NOTE NOTE

If you are not logged on as the Administrator, you will not be able to change any of these settings & you will receive the following error message in your attempt to do so:

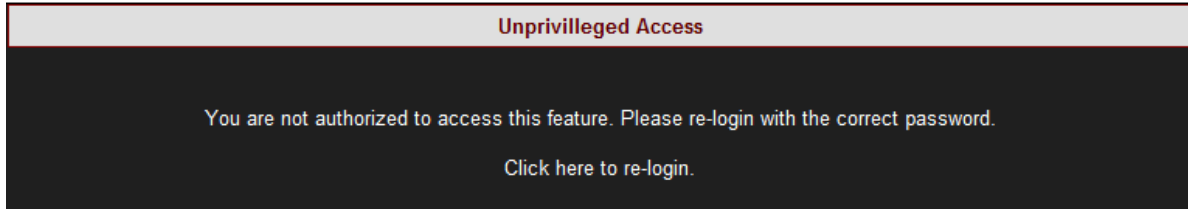

System Log

The **System Log** displays existing user events. All events are created in the [Custom Events](#) & the [Energy](#) & [Parameter](#) Logs are created in [Reports](#). Within in the Log you can decide what data you would like to display & produce a report.

CONFIGURE THE SYSTEM LOG

- [Access](#) the Portable BLACKBOX ➔ log on as the Administrator ➔ under Configuration ➔ [Advanced](#) open the **System Log Tab**:

CONFIGURATION	
Device Setup	Advanced
Device Info	System Log
Time	Custom Events
Voltages & Frequency	PQZIP Recording
Currents	E-mail Alerts
Communication	Reports
Security	Energy Meter
Network	Display Setup
Serial Ports	Firmware Upgrade
PQ Compliance	
Power Compliance	
User Defined Page 1	
User Defined page 2	
User Defined page 3	

- The System Log window will now open:

RWV
■ CONFIGURATION » SYSTEM LOG

Show events of type: [Init] [System] [User] [Measurement]

Start at Page Size Time

Logged Events

#	Event Timestamp	Code	Detailed Event Data
0	21/10/2012 12:54:31	81	FTP Login: IP - 100.100.100.75 user - Arle
1	21/10/2012 09:28:42	80	Telnet Login: user - PQ4xx
2	21/10/2012 09:25:49	81	FTP Login: IP - 100.100.100.78 user - G4kAdmin
3	21/10/2012 09:23:03	81	FTP Login: IP - 100.100.100.78 user - G4kAdmin
4	21/10/2012 09:23:03	81	FTP Login: IP - 100.100.100.78 user - G4kAdmin
5	15/10/2012 18:39:45	80	Telnet Login: user - PQ4xx
6	15/10/2012 18:39:16	102	Network Configuration Changed: LAN2_IP - 100.100.100.87
7	15/10/2012 18:38:30	102	Network Configuration Changed: SNTPS_Alternate - 169.254.249.254
8	15/10/2012 18:38:30	102	Network Configuration Changed: SNTP_Server - 169.254.249.254
9	15/10/2012 18:38:30	102	Network Configuration Changed: LAN2_IP - 169.254.249.247
10	15/10/2012 18:38:30	123	Network Configuration Back to Default (By: 100.100.100.75)
11	15/10/2012 18:31:09	10	PQzip Turned On
12	15/10/2012 18:30:50	145	Line 2 Clamp attached Flex clamp-300A
13	15/10/2012 18:30:40	102	Network Configuration Changed: LAN2_IP - 100.100.100.87
14	15/10/2012 18:30:12	326	Init Process: INIT-DONE

OPTIONS & FUNCTIONS:

- **Show Events of type (Color Coded)** - You may choose the type of events to display in the list:
 - **Init:** Data related to Modem initialization
 - **System:** All Flagged function & configurations related to your Portable BLACKBOX system
 - **User:** All [User-Defined](#) events
 - **Measurement:** All Flagged events related to recording & measurements of your Portable BLACKBOX Device
- **Start at:** Specify the event range for # of entries per page
- **Time:** Log entries will be displayed at specific time zone (UTC or Local time)
- **Logged Events:** Displays the event information (for Code definition see [Creating Custom Events](#) & [Alarms](#))

- **Copy log to clipboard**: Will copy the System Log over to common Windows applications (Notepad, MS Outlook, Excel & Word). Simply select the command & **Paste** it in one of these applications.
- **Erase Log**: Will clear all the log entries & restart the System log from the time you select this option
- **<<**: Go to previous page
- **Refresh Log**: Refresh your view
- **>>**: Go to the next page

SEE ALSO:

- [About Advanced Settings](#)
- [GPS Configuration](#)
- [Create Custom Events](#)
- [Events List](#)
- [E-Mail Alerts](#)
- [About Reports](#)
- [Energy Meter](#)
- [Display Setup](#)
- [Portable BLACKBOX Software \(Firmware\) Upgrade](#)

GPS Configuration

Elspec's Portable BLACKBOX supports a unique time synchronization approach, enabling each individual device to be continuously synchronized to an external to an external time source or to each other. The unique time synchronization algorithm supports two main time-synchronization schemes: SNTP (Network time source) & GPS (GPS time source obtained from satellites). The algorithm presents the highest level availability of time, at an accuracy of 100-200µs for both SNTP & GPS. Once you have Connected the GPS, the device will automatically recognize the connection & you will be able to configure the GPS settings in the Web Interface. The process is two fold & you will need to set the [Time Setup to GPS](#) & configuring the GPS connection itself:

CONFIGURE THE GPS

- Open the [Advanced Settings Tab](#) → select **GPS Module**:

CONFIGURATION	
Device Setup	Advanced
Device Info	System Log
Time	GPS Module
Voltages & Frequency	Custom Events
Currents	PQZIP Recording
Communication	E-mail Alerts
Security	Reports
Network	Energy Meter
Serial Ports	Display Setup
PQ Compliance	Firmware Upgrade
Power Compliance	
User Defined Page 1	
User Defined page 2	
User Defined page 3	

- The **GPS Module Window** will now open:

RW
CONFIGURATION » GPS MODULE

Apply Changes
Refresh Data
Use GPS: Enable

GPS Configuration	
Timestamp	21/12/2012 11:11:00 UTC
Latitude	32 28° 52.32N
Longitude	034 56° 44.55E
Altitude	40.963 m

GPS Configuration	
Signal Quality	GPS fix (SPS)
Status	FIXED
Tracked Satellites	15
Delay (µs)	<input style="width: 50px;" type="text" value="0"/>

Satellite Details			
Sat ID	Elevation	Azimuth	SNR
23	56°	028°	38 dB
16	28°	074°	35 dB
07	52°	224°	37 dB
20	09°	317°	34 dB

- Select **Enable** to enable the GPS's use. The GPS Configuration section will confirm:
- The **Time Stamp**: Date & UTC Time
- **Latitude**: Geographic coordinate that specifies the north-south position of a point on the Earth's surface.
- **Longitude**: Geographic coordinate that specifies the east-west position of the GPS on the Earth's surface.
- **Altitude**: Geographic coordinate that specifies the vertical or "up" direction point of the GPS.
- **Signal Quality**: Displays the manner in which the GPS is synchronized to the signal. In this case SPS - Standard Positioning Service.
- **Status**: **Fixed** means GPS is directed to the satellite. **Not fixed** - means that the GPS is not directed to the satellite. Recheck your GPS connections again, including the Power Source (if in use).
- **Tracked Satellites**: Number of satellites tracked by the GPS.
- **Delay**: If you are using a GPS other than the GPS supplied by Elspec you will need to toggle the phase calculations of the GPS according to the product specifications.
- **Satellite Details**
- To apply your changes select **Apply Changes**  **Refresh Data** to review your changes

SEE ALSO:

- [Connect Serial Ports](#)
- [About Advanced Settings](#)
- [System Log](#)
- [Create Custom Events](#)
- [Events List](#)
- [E-Mail Alerts](#)
- [About Reports](#)
- [Energy Meter](#)
- [Display Setup](#)
- [Portable BLACKBOX Software \(Firmware\) Upgrade](#)

Custom Events - Creating Custom Events

The Custom Events window is used for configuring custom events. Unlike Compliance Configuration, where you are able to only configure power quality events, in this configuration you are free to define any type of event notification. Events can be triggered based on any measured parameters & conditioned by complex logical or mathematical functions.

The Custom Event Section is not related to [Power Quality Event Section](#). The Events setup is based on a custom events engine that works parallel to the power quality events engine allowing the user to define tailored events according to his specific needs. All events triggered in the Portable BLACKBOX device series are stored in the logger (Flash Memory) which is displayed in the [System Log](#). Each event is coded & the following event types with their respective codes can be viewed in the [System Log](#) accordingly:

Event	Event Code Range
System Events	1-200
User Custom Events	201-232
PQ & Compliance Events	233-300

In addition, all events are also stored in the [PQZIP files](#) and can be further analyzed in Elspec's PQSCADA/Investigator Software programs. Furthermore, you may choose to send [E-Mail Alerts](#) on the event and/or receive SMS Text Messages (See PQSCADA's F1 Help Wizard; follow the Components ➔ Server ➔ Configuration ➔ SMS/Text procedure).

In the Custom Events window you will be able to:

- Perform Actions on the Events List
- Create General Event Conditions
- Define Single Type Conditions
- Multiple Type Conditions

CREATING CUSTOM EVENTS

- [Access](#) the Portable BLACKBOX → log on as the Administrator → under **Configuration** → [Advanced](#) open the **Custom Events** Tab:

CONFIGURATION	
Device Setup	Advanced
Device Info	System Log
Time	<u>Custom Events</u>
Voltages & Frequency	PQZIP Recording
Currents	E-mail Alerts
Communication	Reports
Security	Energy Meter
Network	Display Setup
Serial Ports	Firmware Upgrade
PQ Compliance	
Power Compliance	
User Defined Page 1	
User Defined page 2	
User Defined page 3	

- In the **Custom Events** window select **New event** in order to create a **New Event**:

RW ■ CONFIGURATION » CUSTOM EVENTS

Apply Changes
Refresh Data

New event
Clear All
Action on selected events:

Delete ▼
 Delete
 Enable
 Disable
 Reset Counter

Apply Action

Events List

<input type="checkbox"/>	On	Code	Description	Counter
<input type="checkbox"/>	v	201	Event 201	0

Custom Event Configuration
Cancel Save More

Description

Code: 201

Condition
Add New ▼
Edit Condition

Trigger

On Both Begin and End ▼
 At the End Only
 On Begin Only
 On Both Begin and End

 Notify by e-mail

CONFIGURATIONS & DEFINITIONS:

- **Event Preset:** Select User Defined (Preset 1 & 2 used in other applications)
- **Events List:** See [Events List](#) for possible configurations
- **Description:** Used to set a meaningful name for the event
- **Code:** Event code # allocated automatically by the system from the available user events codes & viewed in the [System Log](#)
- **Condition:** An event is based on one or more conditions. There are two types of conditions Single & Multiple. No matter what type of condition is linked to the event, its dependency is dictated by the condition ID string selected in the **Condition** selection box
- **Edit Condition:** Will open the [Edit Condition](#) window
- **Trigger:** An event is basically a logic signal. Anytime a condition is not active, the event remains in a "0" state. When a condition is met, the event becomes "1" state (**On Begin Only**). The event remains on "1" state until the condition is de-activated (**At the End Only**). The trigger configuration field defines what situations will generate an event record. Notification is either on the beginning state, end state, or at both states (**On Both Begin & End**)
- **Notify by E-Mail:** Will send [E-Mail Alerts](#) as soon as the event is triggered
- **Phase Index:** This field should not be changed by user (reserved for future). In general this field defines how phase indication will be recorded with the event.
- **Phase Combination:** Event based on a condition of a 3 phase parameter can be further configured with an additional logic operator in between phases to further mask/enable the event generation. A 3 phase based condition (i.e. 3 phase voltage lines compared to nominal

voltage) will generate 3 parallel activation/deactivation statuses (0->1 changes). In such a 3 phase case the user has the control to determine whether an event is generated only when all 3 phases are activated (AND) or alternatively if at least one of the phases is activated (OR).

- **Minimal Duration:** The duration limit enables the user to limit notification of event based on its duration. In this case you will be able to set a minimum time & events with a lesser duration than the specified time will not be triggered (this is true for the end of the event only; anyhow the beginning of the event will only be reported if it was configured).
- **Maximum Duration:** The duration limit enables the user to limit notification of event based on its duration. The duration limit enables the user to limit notification of an event based on its duration. In this case you will be able to set the maximum time, so that an event that elapses more time than defined won't be triggered.
- **Event Severity Base:** Each recorded event contains a severity factor. This severity factor is a number between 0 and 255, where 0 is no severity at all and 255 is top severity (For instance, PQ compliance events which are part of the Compliance module, uses this severity field to indicate how much voltage/frequency deviates from nominal and how significant the event was based on its duration). The Severity fields define how the events engine will compute a severity factor.
- **Cancel**: Will cancel your configuration
- **Save**: Will save your configuration
- **More** / **Less**: Will open / close the additional configuration settings
- To apply your changes select **Apply Changes** & you will receive the following message:

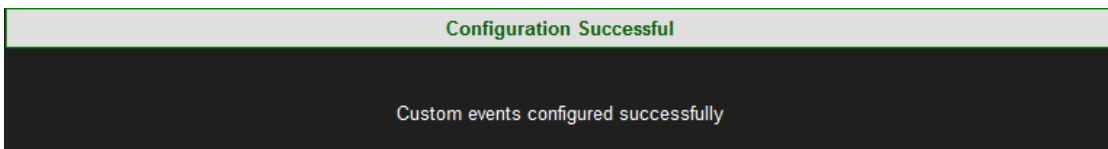

- To refresh your current view select **Refresh Data**

NOTE NOTE NOTE

- If you are not logged on as the Administrator, you will not be able to change any of these settings & you will receive the following error message in your attempt to do so:

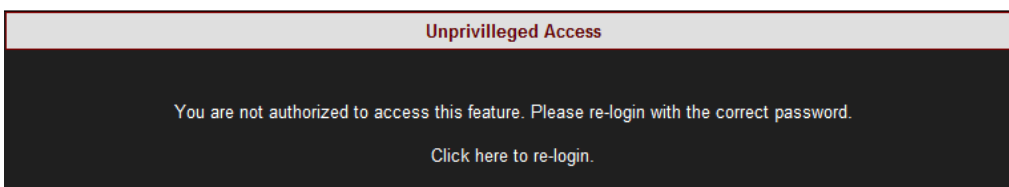

- Every underlined Configuration is accompanied with a Tool Tip (function explanation). In order to activate it, Right-click on the configuration:

Trigger On Both Begin and End ▾

Event is basically a logic signal. Anytime condition is not active the event remain in 0 state. When condition is met, the event become 1 state (beginning of event). The event remains on (1 state) until condition is de-activated (end of event). The trigger configuration field defines on what situations to generate event record. Notification is either on the beginning state, end state or at both cases. Notice that Duration indication of the event will be recorded as zero for beginning state events.

SEE ALSO:

- [About Advanced Settings](#)
- [System Log](#)
- [GPS Configuration](#)
- [Events List](#)
- [E-Mail Alerts](#)
- [About Reports](#)
- [Energy Meter](#)
- [Display Setup](#)
- [Portable BLACKBOX Software \(Firmware\) Upgrade](#)

Events List

After you have [Created a Custom Event](#) the event will appear on the [Events List](#) & [System Log](#). The event will be coded & will appear with their respective codes (as per [Create Custom Events](#)). You may create 31 Custom events.

CONFIGURING EVENTS LIST ACTION

- Each event is preceded with a check-box, select the applicable events that you wish to perform actions for:

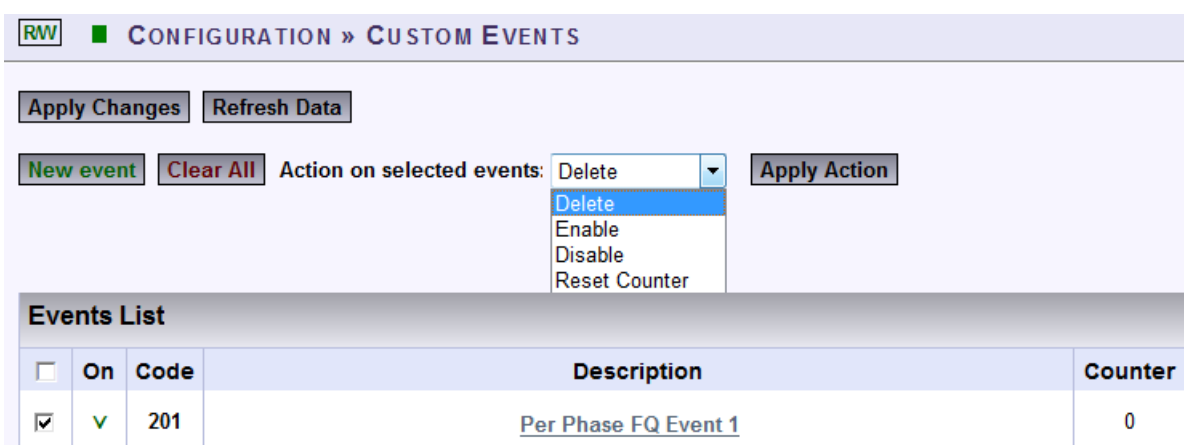

CONFIGURATION » CUSTOM EVENTS

Apply Changes Refresh Data

New event Clear All Action on selected events: Delete ▾ Apply Action

Delete
Enable
Disable
Reset Counter

Events List				
<input type="checkbox"/>	On	Code	Description	Counter
<input checked="" type="checkbox"/>	√	201	Per Phase FQ Event 1	0

- Select **Clear All** to deselect the events that you marked on the **Events List**
- Choose **Action** on selected events:
 - **Delete:** Will enable you to delete the event in case you don't need it anymore
 - **Enable:** Will allow you to enable / activate the event (if disabled previously)

- **Disable:** Will disable / deactivate the event until you wish to enable it at a later stage
- **Reset Counter:** Will enable you to rerun the event at the configured trigger
- Select **Apply Action** to enforce selected actions for the applicable marked event(s) →
select **OK** :

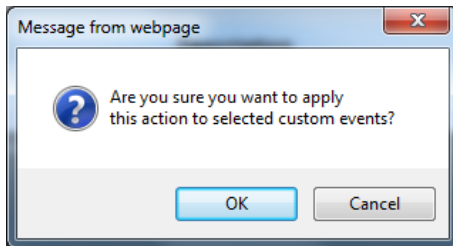

- The following success message will appear:

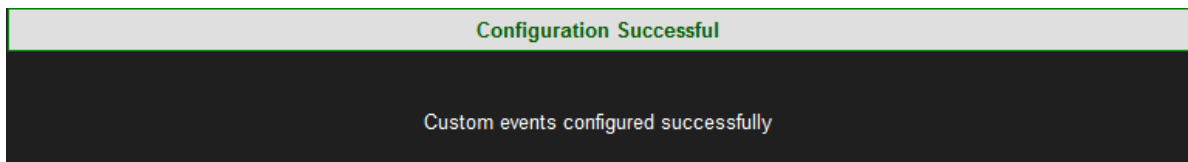

- Clicking on the event will open the event configuration itself & you may edit the configurations as you wish

NOTE NOTE NOTE

If you are not logged on as the Administrator, you will not be able to change any of these settings & you will receive the following error message in your attempt to do so:

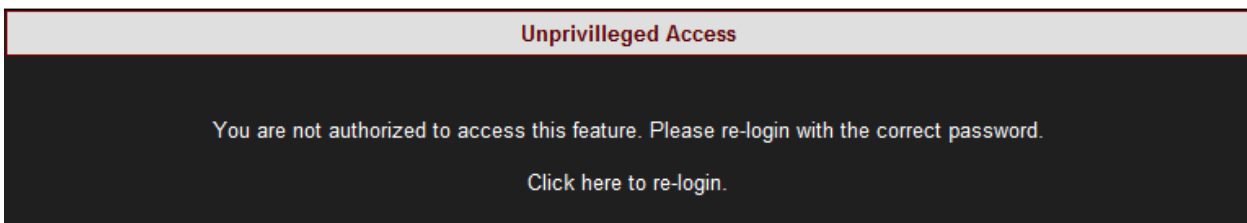

SEE ALSO:

- [About Advanced Settings](#)
- [System Log](#)
- [GPS Configuration](#)
- [Create Custom Events](#)
- [E-Mail Alerts](#)
- [About Reports](#)
- [Energy Meter](#)
- [Display Setup](#)
- [Portable BLACKBOX Software \(Firmware\) Upgrade](#)

Create Event Conditions

Codes 201 - 232 are used for configuring up to 31 different events that are fully customized events. A custom event is typically built from one or more logical/mathematical conditions. When the conditions are met, the event is triggered and the following information is generated and stored:

- Time Stamp of beginning
- Event Code number
- Duration of event
- Magnitude (A parameter value recorded during the event)
- Magnitude deviation (from the normal/configured value/threshold)
- Phases that were influenced
- Severity of the Event (value indicating how severe the event is)

Although the information implies a power related event, you are free to configure other type of events that are not related to specific power network parameters, such as digital input-based events or even temperature-based events and so on. (In such cases the Phases involved information should be left blank/ignored.)

Events can also be based on multiple conditions. For example: an event will be triggered should the voltage exceed threshold (x) and the outside (PT-100) temperature exceeds (x) limit.

This page contains buttons for applying changes/creating/deleting and performing various actions on selected events.

CREATE EVENT CONDITIONS

- [Access](#) the Portable BLACKBOX → log on as the **Administrator** → under **Configuration** → [Advanced](#) open the [Custom Events Tab](#)
- After selecting [Create New Events](#) → naming the event in **Description** → select [Edit Condition](#) to open the **Condition Window**:



- **Name the Condition** & you will need to create a [Single Condition](#) in order to create [Multiple Conditions](#):
 - **ID:** The ID Condition is identified by a text ID. Two conditions cannot be set to the same ID string.
 - **The Single-Type Condition:** Defined as the result of some rule (mathematical operation on some system parameters). For instance, a percentage voltage drops below the threshold or a change of digital input & so on. The condition has 2 logic states, Activated (1) and De-activated (0). Transition to each state is fully configured by the user.
 - **A Multiple-Type Condition:** Is the combination of 2 other sub conditions. A Multiple-type condition must be linked to 2 sub conditions, each of these 2 sub conditions can be either Multiple or Single type. Therefore, the Multiple-type condition can be used to create a complex hierarchy of conditions.
- Go to the next steps creating [Single Conditions](#) and/or [Multiple Conditions](#)

SEE ALSO:

- [About Advanced Settings](#)
- [System Log](#)
- [GPS Configuration](#)
- [Create Custom Events](#)
- [Events List](#)
- [E-Mail Alerts](#)
- [About Reports](#)
- [Energy Meter](#)
- [Display Setup](#)
- [Portable BLACKBOX Software \(Firmware\) Upgrade](#)

Single Type Conditions

As mentioned previously **Single Type Conditions** are used to define the result of an occurrence (example - voltage drops below the threshold) or a change of digital input & so on. You will need to configure the condition, including the transition of the condition from the **Activated** to the **Deactivated** State.

CONFIGURE SINGLE TYPE CONDITIONS

- [Access](#) the Portable BLACKBOX → log on as the **Administrator** → under **Configuration** → [Advanced](#) open the [Custom Events Tab](#)
- After selecting [Create New Events](#) → naming the event in **Description** → select [Edit Condition](#) to open the **Condition Window**
- Select **Single** for the **Type** → open the [More](#) / [Less](#) in order to view the additional configuration options:

Condition Configuration
Cancel Save More

ID: (# 1) Type:

Based on: Parameter (X):

Based on:

- Per phase [V/I], Frequency
- 3 Phase [V/I]
- Digital Inputs [0/1 levels]
- Per Phase [P/Q/S]
- PF, THD, Unbalance
- Harmonics
- Temperature
- [10ms] Fast RMS
- Cycle-By-Cycle [I/V]

Parameter (X):

- I1 RMS
- I2 RMS
- I3 RMS
- V1 RMS
- V2 RMS
- V3 RMS
- V12 RMS
- V23 RMS
- V31 RMS
- Frequency

Activation

Compare to: Parameter: Nominal I1

Deviation (D): %

Operation:

- No op
- X=V
- X>=V
- X<V
- X!=V
- 100*(X/V)>=D
- 100*(X/V)<D
- 100*((X-V)/V)>=D
- 100*((V-X)/V)>=D
- 100*((X-V)/V)>=D
- 100*((X-V)/V)<D
- 100*((V-X)/V)<D
- 100*((X-V)/V)<D

Deactivation

Compare to: Parameter: Nominal I1

Deviation (D): %

Operation:

- No op
- X=V
- X>=V
- X<V
- X!=V
- 100*(X/V)>=D
- 100*(X/V)<D
- 100*((X-V)/V)>=D
- 100*((V-X)/V)>=D
- 100*((X-V)/V)>=D
- 100*((X-V)/V)<D
- 100*((V-X)/V)<D
- 100*((X-V)/V)<D

CONFIGURATIONS:

- **Based on:** For parameter selection to base your condition on
- **Parameter (X):** Used to select the specific parameter from a previously selected group. The selected parameter will be used as the "X" variable in the condition rules (operation)
- **Magnitude Calculation:** Determines the way the condition engine will compute the resulting magnitude of change in accordance to its set of rules. For example if defined a voltage change rule, where now voltage ("X") is 280V while its reference ("V") is 230V, the computed deviation now will be 21% - this is the instant deviation, but what happens if event continues and the next value sampled is 260V? Now the deviation is only 13% so what value should be reported? The "Magnitude calculation" field defines how the value is being computed. It is either by saving the maximum deviation measured or by average in between all values measured during the event

- **Averaging Time:** Setting averaging time enables the user to extend the sampling interval. For instance if user selected "3 phase differential V" parameter, the typical time is 200[ms] (per IEC-61000-4-30). Yet, if the user change it to 3sec, it means the value will be averaged and a sample will be taken only every 3 seconds, meaning that quick rapid change of voltage will be smoothed by the averaging operation and would not be detected
 - **Activation Section:** Used to configure the rules that will be applied to cause real-time activation of the condition (change from 0 -> 1). For example, if you set the following: Voltage RMS 1 (X = V1), compare to is set to the configured Nominal voltage (say, V = 230V), Deviation is set 10 (D = 10%) and Operation is set $100 * (|X - V| / V) \geq D$, the condition will be activated when the RMS voltage of channel 1 goes 10% above or 10% below nominal voltage
 - **Deactivation Section:** Used to configure the rules that will be applied to cause real-time de-activation of the condition (change from 1 -> 0). For example, if you set the following: Voltage RMS 1 (X = V1), Compare to is set to the configured Nominal voltage (say, V = 230V), Deviation is set 10 (D = 10%) and Operation is set $100 * (|X - V| / V) < D$, the condition will be de-activated when the RMS voltage of channel 1 goes below 10% deviation from nominal
- **Compare to:** Used to select the type of reference value ("V") to compare to the X parameter value
- **Parameter:** Reference to system parameter such as nominal voltage value
- **Deviation ("D"):** Defines the value used in the operation formula. Notice that some operations do not contain deviation; in such cases the deviation configuration is not in use
- **Operation:** Defines the rule or mathematical operation to apply for Activation or Deactivation of condition. User Value enables the user to edit his own reference value
- **Operation Logic (And / Or):** This operation logic field defines the logic to be applied between 2 operations for enabling activation or deactivation in accordance. By using two operations & a logical operation in between, the user can define a more complex condition rule
- **Second Deviation:** This field defines the additional Deviation ("D%") value used in the operation formula. Note that some operations does not contains deviation, in this case the deviation configuration is not in use
- **Second Operation:** This operation list defines the additional mathematical operation to apply for Activation/Deactivation of condition
- Select / to Save / Cancel your configuration in **Condition Configuration**
- You will receive the following Success Message:

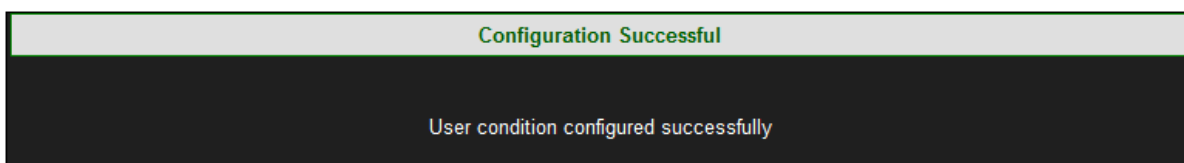

- Proceed either to creating [Multiple Type Conditions](#) or conclude your configuration as per [Create Custom Events](#)

NOTE NOTE NOTE

If you are not logged on as the Administrator, you will not be able to change any of these settings & you will receive the following error message in your attempt to do so:

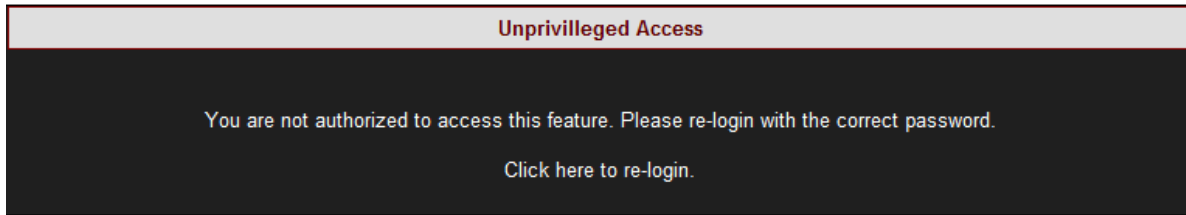

SEE ALSO:

- [Create Custom Events](#)
- [Events List](#)

Multiple Type Conditions

As mentioned previously, **Multiple Type Conditions** is the combination of 2 other sub conditions. It needs to be linked to 2 sub conditions, whereas each 2 sub conditions can be either **Multiple** or **Single type**. Therefore, you need to configure at least two **Single types** of conditions prior to proceeding in creating a hierarchy of **Multiple Conditions**.

CONFIGURE MULTIPLE TYPE CONDITIONS

- [Access](#) the Portable BLACKBOX ➔ log on as the **Administrator** ➔ under **Configuration** ➔ [Advanced](#) open the [Custom Events Tab](#)
- From the listed events in the [Events List](#) select the applicable event with 2 or more [Single Type Conditions](#) ➔ & select [Edit Condition](#) to open the **Condition Window**
- Select **Multiple** for the **Type**:

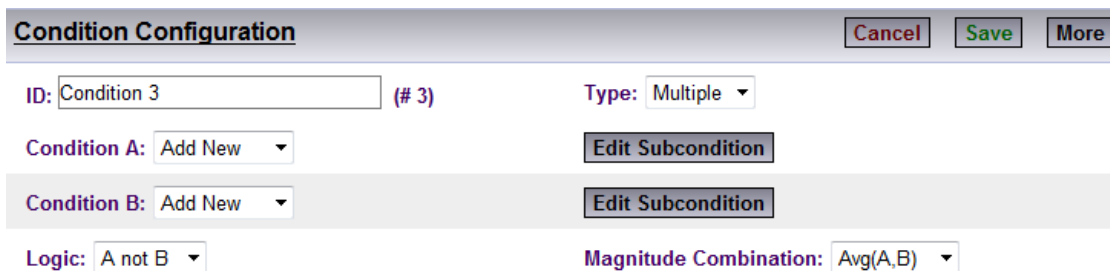

Condition Configuration [Cancel] [Save] [More]

ID: (# 3) Type:

Condition A:

Condition B:

Logic: Magnitude Combination:

Configuration Options:

- **Condition A:** Is used to select ID of first sub-condition
- **Condition B:** Is used to select ID of second sub-condition
- **Logic:** Is used to define the combined logic state between the two sub-conditions A and B
- **Magnitude Combination:** Instructs the events engine how to compute the Magnitude resulting from a combined condition. For instance, say condition A and condition B are both voltage parameters. In this case, selecting Avg. (Average) or Max (Maximum) is practical. However if condition A is voltage and condition B is current, then AVG or MAX is irrelevant, while an A-only option is more practical (meaning only magnitude of voltage from condition A will be taken)
- Select / to Save / Cancel your configuration in **Condition Configuration**
- You will receive the following Success Message:

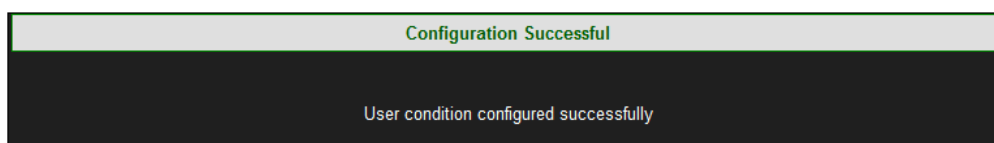

- Conclude your configuration as per [Create Custom Events](#)

NOTE NOTE NOTE

If you are not logged on as the Administrator, you will not be able to change any of these settings & you will receive the following error message in your attempt to do so:

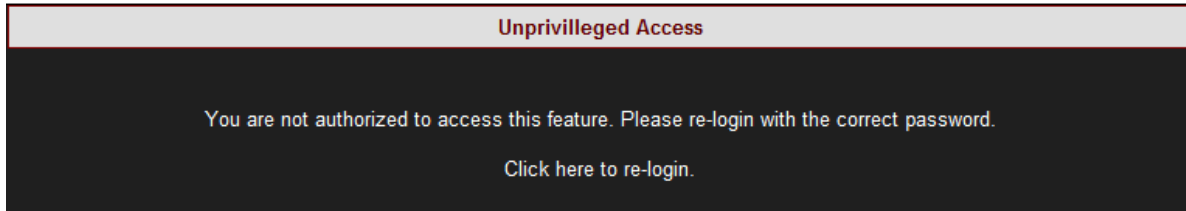

SEE ALSO:

- [Create Custom Events](#)
- [Events List](#)

E-Mail Alerts

Your Portable BLACKBOX can be configured to send E-Mail alerts to any recipient(s) entered in the "To" text box. This configuration also allows you to choose which alert(s) you would like to be notified on from a wide range of configurations, i.e.: [System](#), [Connections](#), [Firmware Updates](#), [PQZIP](#), [Compliance Events](#), [PQ Events](#) & [Custom Events](#).

CONFIGURE THE G4500/G3500 TO SEND E-MAIL ALERTS

- [Access](#) the Portable BLACKBOX unit via Elspec's Web Interface → log on as the **Administrator** → select the **Configuration Tab**
- Under the **Advanced** section select **E-Mail Alerts**:

CONFIGURATION	
Device Setup	Advanced
Device Info	System Log
Time	Custom Events
Voltages & Frequency	PQZIP Recording
Currents	<u>E-mail Alerts</u>
Communication	Reports
Security	Energy Meter
Network	Display Setup
Serial Ports	Firmware Upgrade
PQ Compliance	
Power Compliance	
User Defined Page 1	
User Defined page 2	
User Defined page 3	

- The E-Mail Alerts window will now open & you need to enter the exact **E-Mail Address(s)** (without spaces, for multiple E-Mails enter a ; as a separator between the E-Mails). Make sure that you are connected to the pre-configured [SMTP server](#) that will have the e-mails already setup within the server:

E-mail Configuration

'TO' address:

- Under each section (you may collapse / expand with) select the **Configuration** on which you will need to send/receive E-Mail Alerts:

SYSTEM:

System <input type="button" value="▲"/>	
<input checked="" type="checkbox"/> Power Up	<input checked="" type="checkbox"/> Watchdog Reset
<input checked="" type="checkbox"/> Power Loss	<input checked="" type="checkbox"/> System Startup
<input checked="" type="checkbox"/> Shutdown Started	<input checked="" type="checkbox"/> Shutdown Done
<input checked="" type="checkbox"/> Shutdown on Power Loss	<input checked="" type="checkbox"/> Shutdown on Error
<input checked="" type="checkbox"/> User Shutdown	<input checked="" type="checkbox"/> Event Log Erased
<input checked="" type="checkbox"/> Parameter Block Corrupted	<input checked="" type="checkbox"/> Read Meter Log File End
<input checked="" type="checkbox"/> Voltage Dropdown	<input type="checkbox"/> Reserved

SEE ALSO: [About Instrument Settings](#)

CONNECTIONS:

Connections <input type="button" value="▲"/>	
<input checked="" type="checkbox"/> HTTP Connected	<input checked="" type="checkbox"/> TCPIP Connected
<input checked="" type="checkbox"/> OPC Connected	<input checked="" type="checkbox"/> Serial Connected
<input checked="" type="checkbox"/> FTP Login	<input checked="" type="checkbox"/> Telnet Login
<input checked="" type="checkbox"/> Main SNMP	Reserved
<input checked="" type="checkbox"/> IP Changed	<input checked="" type="checkbox"/> Time Synchronized
<input checked="" type="checkbox"/> Connection Closed	<input checked="" type="checkbox"/> Network Reset

SEE ALSO: [About Network Setup](#)

FW UPGRADE:

FW Update <input type="button" value="▲"/>	
<input checked="" type="checkbox"/> FW Update Started	<input checked="" type="checkbox"/> FW Update OK
<input checked="" type="checkbox"/> New FW Launched	<input checked="" type="checkbox"/> FW Update Failure

SEE ALSO: [Firmware Upgrade](#)

PQZIP:

PQZip	
<input checked="" type="checkbox"/> PQZip Enabled	<input checked="" type="checkbox"/> PQZip Disabled
<input checked="" type="checkbox"/> PQZip Flushed	<input checked="" type="checkbox"/> PQZip Data Clear
<input checked="" type="checkbox"/> PQZip Events Dropped	<input checked="" type="checkbox"/> PQZip Start Failed
<input checked="" type="checkbox"/> Compact Flash Format	<input checked="" type="checkbox"/> CF Format Failed

SEE ALSO: About [PQZIP Recording](#)

COMPLIANCE EVENTS:

Compliance Events	
<input checked="" type="checkbox"/> Evaluation Started	<input checked="" type="checkbox"/> Evaluation Stopped
<input checked="" type="checkbox"/> Evaluation State Changed	<input checked="" type="checkbox"/> Report Generation

SEE ALSO: [PQ Compliance Configuration](#)

PQ EVENTS:

PQ Events	
<input type="checkbox"/> Voltage Frequency	<input checked="" type="checkbox"/> Supply Voltage Variations
<input type="checkbox"/> Supply Voltage Dips	<input checked="" type="checkbox"/> Short Interruptions
<input type="checkbox"/> Temporary Overvoltage	<input type="checkbox"/> Supply Voltage Unbalance
<input type="checkbox"/> Harmonic Voltage	<input type="checkbox"/> Flicker Severity
<input type="checkbox"/> Rapid Voltage Changes	<input checked="" type="checkbox"/> Long Interruptions

SEE ALSO: [About Monitoring Real Time Data](#)

CUSTOM EVENTS:

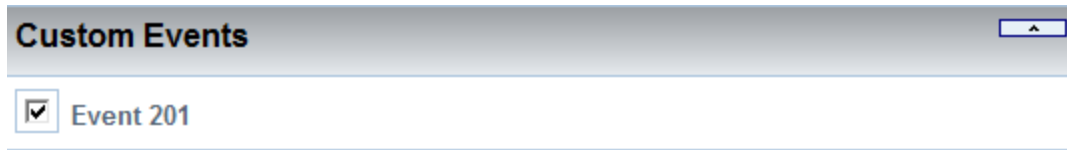

SEE ALSO: [Custom Events](#)

- Select [Send Test Alert](#) to send a Test E-Mail
- To apply your changes select [Apply Changes](#)
- In order to refresh your screen & view the changes select [Refresh Data](#)

NOTE NOTE NOTE

- If you are not logged on as the Administrator, you will not be able to change any of these settings & you will receive the following error message in your attempt to do so:

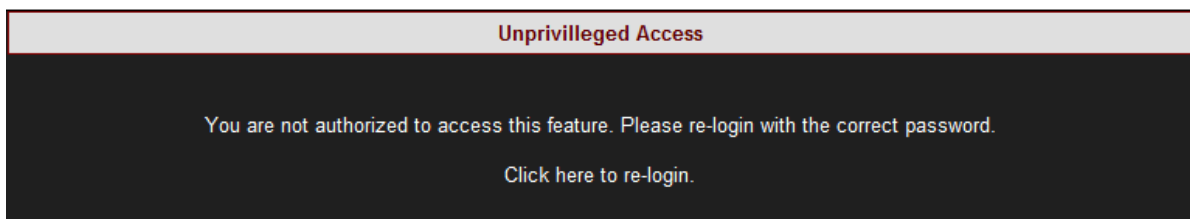

- Once you have signed on at the Administrator ensure that you select [Apply Changes](#) to actually affect your changes.
- Ensure that you are connected to the pre-configured SMTP server that will have the e-mails already setup within the server.

SEE ALSO:

- [About Advanced Settings](#)
- [System Log](#)
- [GPS Configuration](#)
- [Create Custom Events](#)
- [Events List](#)
- [About Reports](#)
- [Energy Meter](#)
- [Display Setup](#)
- [Portable BLACKBOX Software \(Firmware\) Upgrade](#)

Reports - About Reports

The Portable BLACKBOX saves & copies reports over to its internal Compact Flash memory. This report includes 2 log types namely: **Energy & Parameter Logs**. As in many cases this may include a vast amount of information. Therefore it is recommended that you:

1. Configure the unit to send you [E-Mail Alerts](#) (mark Report Generation under Compliance Events) once it has concluded the report.
2. You retrieve the reports from the BLACKBOX's CF Memory via **FTP Server**. Access the FTP server via Elspec's Search Utility & the file is located under **Reports**. (Any user may copy the log over to this location). Retain the reports on the CF memory only when necessary in order to not occupy unnecessary disc space.

USING THE METER READING LOG

In this window you will be able to configure the report to include modes for either [Energy](#) or [Parameter](#) logs

- [Access](#) the Portable BLACKBOX via **Elspec's Web Interface** ➔ log on as the **Administrator**
➔ select the **Configuration Tab**
- Under the **Advanced** section select **Reports**:

CONFIGURATION	
Device Setup	Advanced
Device Info	System Log
Time	Custom Events
Voltages & Frequency	PQZIP Recording
Currents	E-mail Alerts
Communication	Reports
Security	Energy Meter
Network	Display Setup
Serial Ports	Firmware Upgrade
PQ Compliance	
Power Compliance	
User Defined Page 1	
User Defined page 2	
User Defined page 3	

- Select:

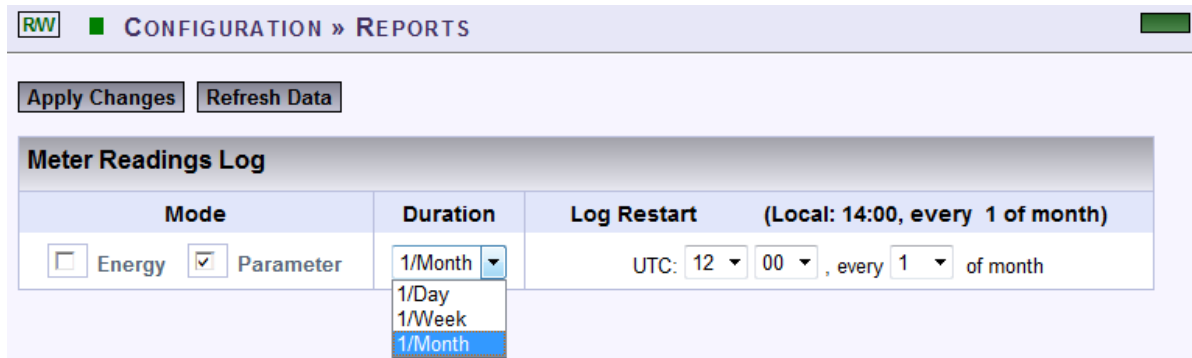

Mode	Duration	Log Restart	(Local: 14:00, every 1 of month)
<input type="checkbox"/> Energy <input checked="" type="checkbox"/> Parameter	1/Month <ul style="list-style-type: none"> 1/Day 1/Week 1/Month 	UTC: 12 00	, every 1 of month

- Mode [Energy](#) or [Parameter](#)
- Duration: 1 Day, 1 Month, 1 Week
- Log Restart: At - Time Local to UTC Time / Every - 1-25th of the Month
- To apply your changes select [Apply Changes](#)
- In order to refresh your screen & view the changes select [Refresh Data](#)

NOTE NOTE NOTE

If you are not logged on as the Administrator, you will not be able to change any of these settings & you will receive the following error message in your attempt to do so:

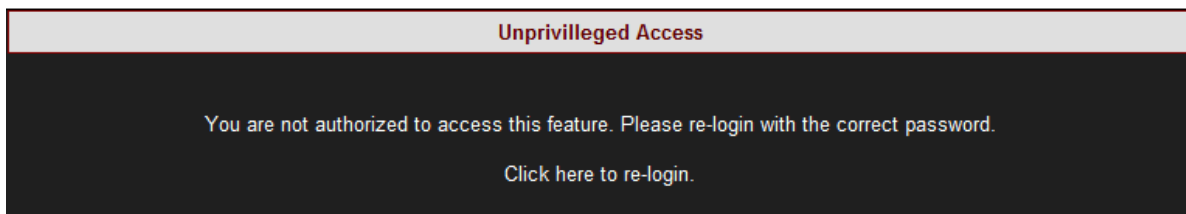

SEE ALSO:

- [About Advanced Settings](#)
- [System Log](#)
- [GPS Configuration](#)
- [Create Custom Events](#)
- [Events List](#)
- [E-Mail Alerts](#)
- [Energy Meter](#)
- [Display Setup](#)
- [Portable BLACKBOX Software \(Firmware\) Upgrade](#)

Energy Mode

The information included in the [Report](#) includes data from the total [Energy Meter](#). The information is saved on the compact flash & retrievable from the FTP under: `/CF_UPMB/Reports` & is saved in a `.csv` file format. As such the report can be viewed in Excel & be sent as an E-Mail attachment. The values that are saved in this report include:

- Kwh In
- Kwh Out
- KVArh In
- KVArh Out
- KVAh

NOTE NOTE NOTE

The values of the total energy meter are saved in the PQZIP files even if the Meter Readings Log is disabled.

SEE ALSO:

- [How to create Reports](#)
- [Parameter Mode](#)

Parameter Mode

The information included in the [Report](#) includes data from [PQ Compliance](#). The information is saved on the compact flash & retrievable from the FTP under: **/CF_UPMB/Reports** & is saved in PDF / Excel (According to the Applicable Standard) file format. As such the report can be viewed in Excel & be sent as an E-Mail attachment. The values that are saved in this report include:

- **Kw (Power):** Average, standard deviation, maximum and minimum values
- **Frequency:** Average, standard deviation, maximum and minimum values
- **KVAr:** Average, standard deviation, maximum and minimum values

NOTE NOTE NOTE

The parameter log can be customized to include any other three parameters. For this configuration please contact your local Elspec representative.

SEE ALSO:

- [How to create Reports](#)
- [Energy Mode](#)

Energy Meter

The Portable BLACKBOX Device Series is equipped with 3 Energy Meters for continuously recording & measuring all the electrical energy. The meters measure:

- Current Period,
- Total Consumption &
- Demand

CONFIGURING THE ENERGY CALCULATIONS FOR THE ENERGY METERS

In this window you will be able to configure the energy calculations of these meters by time & the method of averaging:

- [Access](#) the Portable BLACKBOX via **Elspec's Web Interface** → log on as the **Administrator**
→ select the **Configuration Tab**
- Under the **Advanced** section select the **Energy Meter Tab**:

CONFIGURATION	
Device Setup	Advanced
Device Info	System Log
Time	Custom Events
Voltages & Frequency	PQZIP Recording
Currents	E-mail Alerts
Communication	Reports
Security	<u>Energy Meter</u>
Network	Display Setup
Serial Ports	Firmware Upgrade
PQ Compliance	
Power Compliance	
User Defined Page 1	
User Defined page 2	
User Defined page 3	

- The Energy Intervals window for the Energy Meters will now open:

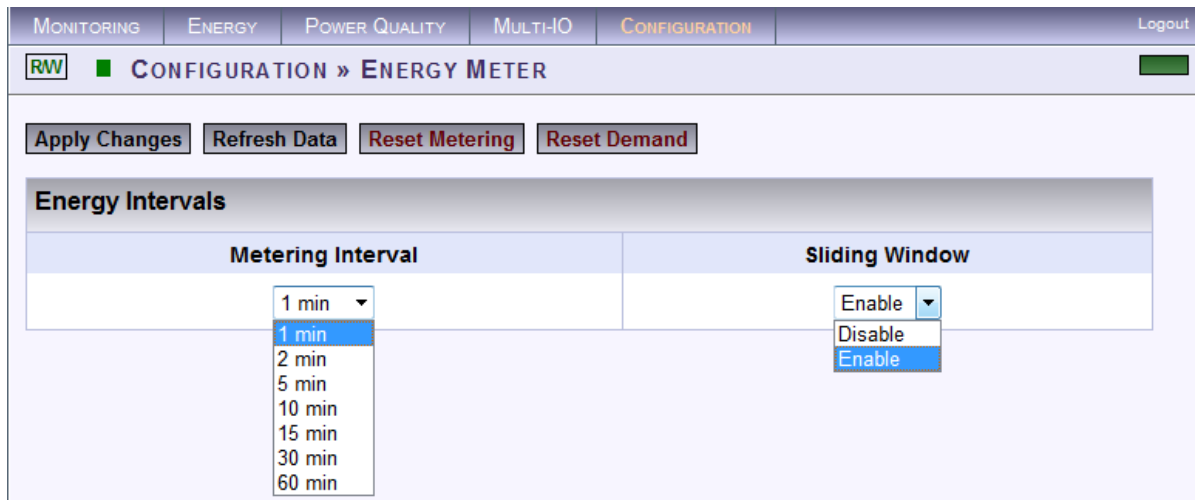

In the 2 Sections Select:

- Metering Interval:** This sets the meters to measure energy according to a preset interval (1, 2, 5, 10, 15, 30 & 60 minutes)
- Sliding Window (Applicable For The Demand Meter):** The energy is calculated using moving average time intervals (1 second). Options:

SLIDING WINDOW ENABLED:

- Enable:** The energy is calculated using a sliding window. The figure below illustrates the time increment as 1 second:

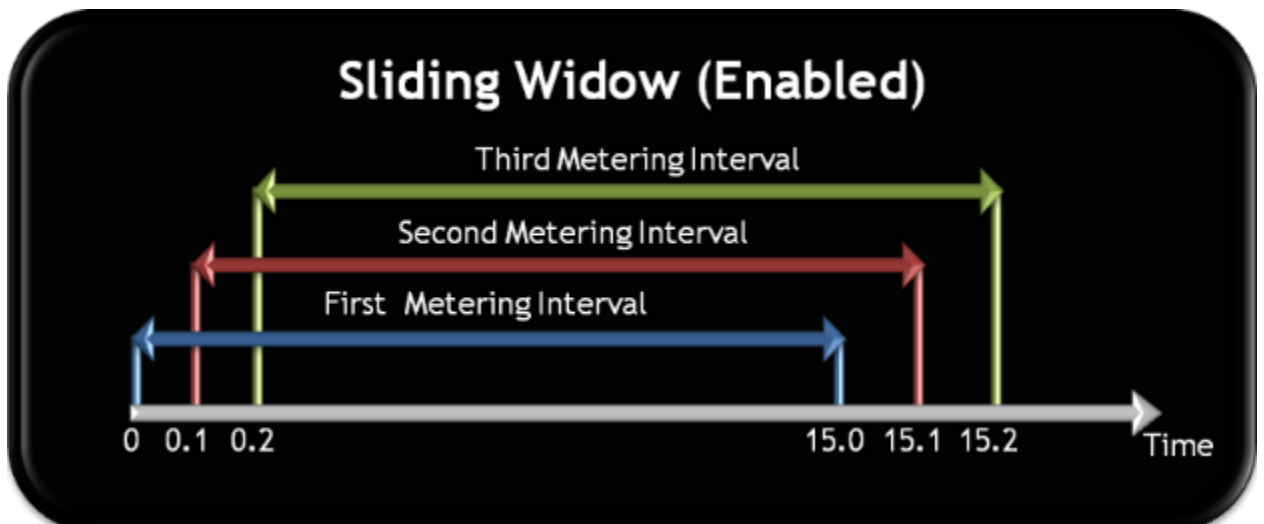

SLIDING WINDOW DISABLED:

- **Disable:** The energy is calculated using fixed interval for each meter illustration:

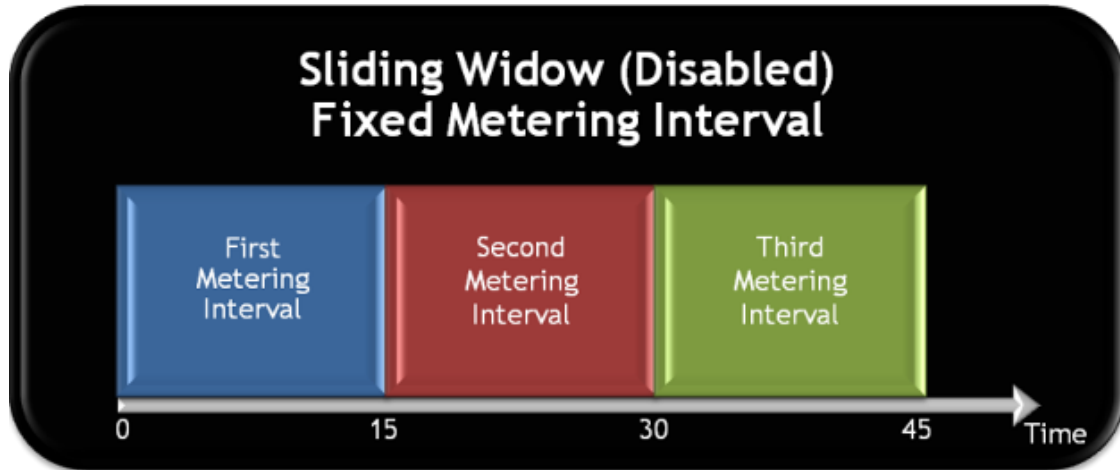

- To ensure that you have reset the **All the Meters** select Reset Metering
- To reset only the **Demand Meter** select Reset Demand
- To apply your changes select Apply Changes
- In order to refresh your screen & view the changes select Refresh Data

NOTE NOTE NOTE

If you are not logged on as the Administrator, you will not be able to change any of these settings & you will receive the following error message in your attempt to do so:

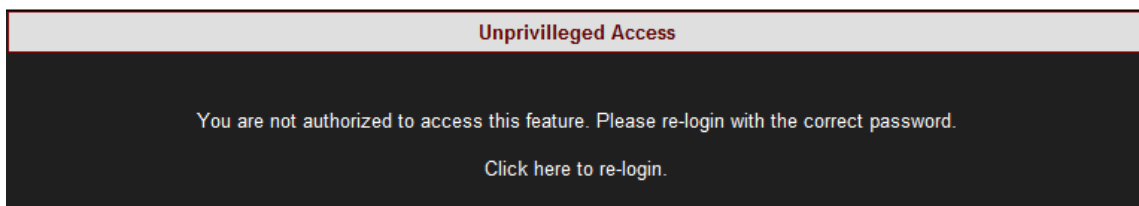

SEE ALSO:

- [About Advanced Settings](#)
- [System Log](#)
- [GPS Configuration](#)
- [Create Custom Events](#)
- [Events List](#)
- [E-Mail Alerts](#)
- [About Reports](#)
- [Display Setup](#)
- [Portable BLACKBOX Software \(Firmware\) Upgrade](#)

Display Setup

The Display Setup page enables you to customize your Portable BLACKBOX to display regional & generic display preferences for both Elspec's Web Interface & for your G4100 RDU.

- [Access](#) the Portable BLACKBOX via Elspec's Web Interface → log on as the Administrator
→ select the **Configuration Tab**
- Under the **Advanced** section select the **Display Setup Tab**:

CONFIGURATION	
Device Setup	Advanced
Device Info	System Log
Time	Custom Events
Voltages & Frequency	PQZIP Recording
Currents	E-mail Alerts
Communication	Reports
Security	Energy Meter
Network	<u>Display Setup</u>
Serial Ports	Firmware Upgrade
PQ Compliance	
Power Compliance	
User Defined Page 1	
User Defined page 2	
User Defined page 3	

- The **Display Setup** window will now open:

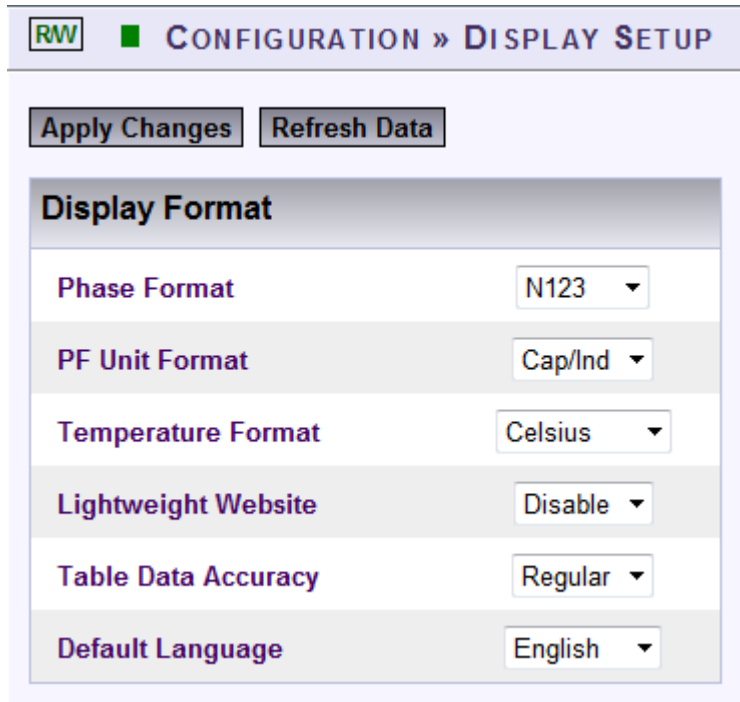

Display Setup Configuration

Buttons: **Apply Changes** | **Refresh Data**

Display Format	
Phase Format	N123
PF Unit Format	Cap/Ind
Temperature Format	Celsius
Lightweight Website	Disable
Table Data Accuracy	Regular
Default Language	English

Configuration Options:

- **Phase Format:** Format that will be used to indicate phases. For example: V1,V2,V3 ; VA,VB,VC; Vx Vy, Vz; etc.
 - **PF Unit Format:** Format that will be used to indicate the PF Unit. For example: For Capacitive/Inductive select **Cap/Ind**
 - **Temperature Format:** Preferred temperature measurements in either **Celsius / Fahrenheit**
 - **Lightweight Website:** When disabled, the web interface doesn't use any images (and also flash on the login page) in order to speed up your connection. It is recommended when the network connection to the unit is weak.
 - **Table Data Accuracy:** **Extra** will extend the display to 7 digits (230.5612) & **Regular** will extend the display to 5 digits (230.56)
 - **Default Language:** Select your default system language
- To apply your changes select **Apply Changes**
 - In order to refresh your screen & view the changes select **Refresh Data**

NOTE NOTE NOTE

If you are not logged on as the Administrator, you will not be able to change any of these settings & you will receive the following error message in your attempt to do so:

Unprivileged Access

You are not authorized to access this feature. Please re-login with the correct password.

[Click here to re-login.](#)

SEE ALSO:

- [About Advanced Settings](#)
- [System Log](#)
- [GPS Configuration](#)
- [Create Custom Events](#)
- [Events List](#)
- [E-Mail Alerts](#)
- [About Reports](#)
- [Energy Meter](#)
- [Portable BLACKBOX Software \(Firmware\) Upgrade](#)

Upgrade BLACKBOX Software - About Firmware Upgrade

The internal software of the Portable BLACKBOX device series is named Firmware (FW). On every upgrade (every couple of months) Elspec will announce the new release accompanied by the features, benefits, access & upgrade instructions. The latest version is located on [Elspec's Website](#). It is recommended that you take advantage of every new upgrade, but it is not compulsory. In the Firmware Upgrade window you will be able to:

- [Upgrade the FW directly using the FTP, or](#)
- [Upgrade the FW locally \(Recommended\)](#)

ACCESS THE FIRMWARE UPGRADE WINDOW

- [Access](#) the Portable BLACKBOX via [Elspec's Web Interface](#) ➡ log on as the **Administrator**
➡ select the **Configuration Tab**
- Under the **Advanced** section select the **Firmware Upgrade Tab**:

CONFIGURATION	
Device Setup	Advanced
Device Info	System Log
Time	Custom Events
Voltages & Frequency	PQZIP Recording
Currents	E-mail Alerts
Communication	Reports
Security	Energy Meter
Network	Display Setup
Serial Ports	Firmware Upgrade
PQ Compliance	
Power Compliance	
User Defined Page 1	
User Defined page 2	
User Defined page 3	

- The Firmware Upgrade window will now open:

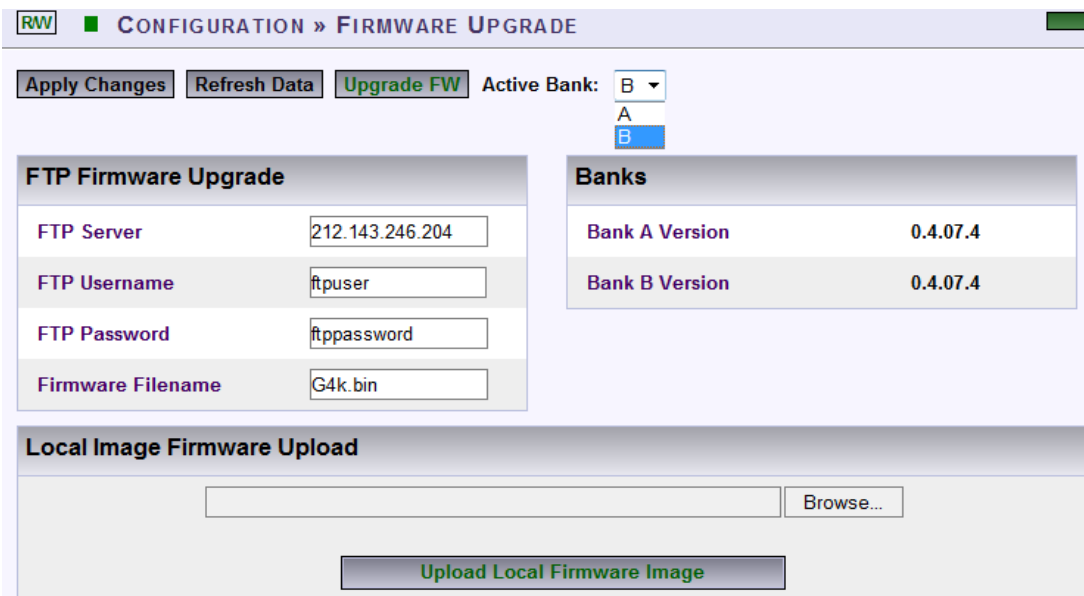

IN THE BANKS SECTION:

The BLACKBOX implements a comprehensive Firmware management mechanism designed to ensure a failure-free field upgrading functionality. The mechanism ensures that at any time there are two Firmware images available, where only one are active (running). The user may select which one of the two banks is the active bank. When the user initiates a Firmware upgrade, the newly added Firmware will load into the inactive bank. Once the process of uploading the new Firmware is completed, the unit will reboot from the inactive bank, turning it into the active bank.

OPTIONS & DISPLAY

- **Active Bank:** Indicates which Firmware Bank is actually in use. Select the applicable version Bank A/B
- **Bank A/B Version:** Displays a Bank's Firmware and condition. A numeric only Firmware name means it's a valid Firmware, which is ready to use. In some situations the Firmware could be further marked with a prefix character to identify a Firmware status. The table below describes status prefixes available:

PREFIX	STATUS
*	The Firmware was upgraded and a reboot is pending to activate the image for the first time. The user is free to initiate reboot manually to complete the upgrading procedure.
F	The Firmware image failed to complete the initialization process successfully. The Firmware was declared as "Faulty", another bank is being used.
W	The Firmware bank is being upgraded at the moment, wait for the completion.

E	The bank is empty.
---	--------------------

Note Note Note

Should Firmware 0.4.03.3 be found faulty/damaged/corrupted it will appear as F0.4.03.3 on the Bank A/B version field. In such a case it is recommended to check if the Firmware file is authentic and attempt to upgrade it again.

SEE ALSO:

- [About Advanced Settings](#)
- [System Log](#)
- [GPS Configuration](#)
- [Create Custom Events](#)
- [Events List](#)
- [E-Mail Alerts](#)
- [About Reports](#)
- [Energy Meter](#)
- [Display Setup](#)

Upgrade the FW Using FTP

An alternative option of upgrading your instrument is by using an FTP (File Transfer Protocol) interface. The BLACKBOX employs an FTP client module which is capable of downloading a Firmware image file from an external FTP server automatically. Prior to using this option, ensure that you have [Established Communication](#) & that your Portable BLACKBOX Unit has been configured for FTP access.

FTP UPGRADE

The FTP firmware upgrade functionality is configured in the FTP Firmware Upgrade section. The factory default configuration settings define an ELSPEC Corporate FTP server which is loaded with the latest released firmware. Alternatively, any other FTP server could be used. We recommend Filezilla, a free FTP server (<http://filezilla-project.org/>) or similar.

- [Access](#) the Portable BLACKBOX via [Elspec's Web Interface](#) → log on as the **Administrator** → select the **Configuration Tab** → **Advanced** → **Firmware Upgrade Tab**
- In the **FTP Firmware Upgrade Section** insert:

FTP Firmware Upgrade	
FTP Server	<input type="text" value="212.143.246.204"/>
FTP Username	<input type="text" value="ftpuser"/>
FTP Password	<input type="text" value="ftppassword"/>
Firmware Filename	<input type="text" value="G4k.bin"/>

- **FTP Server:** The IP address of the external FTP server where the firmware file is located. The default setting is: 212.143.246.204 which is the ELSPEC's FTP server which is loaded with a latest released Firmware
 - **Firmware User-Name:** The [User-Name to login](#) to the FTP server
 - **Firmware Password:** The [Password to login](#) to the FTP server
 - **Firmware Filename:** As default, the latest Firmware located under Elspec's FTP server is G4k.bin
- For your changes to be taken into effect select **Upgrade FW** after which you'll receive a success message & the unit will automatically restart on completion of the upgrade:

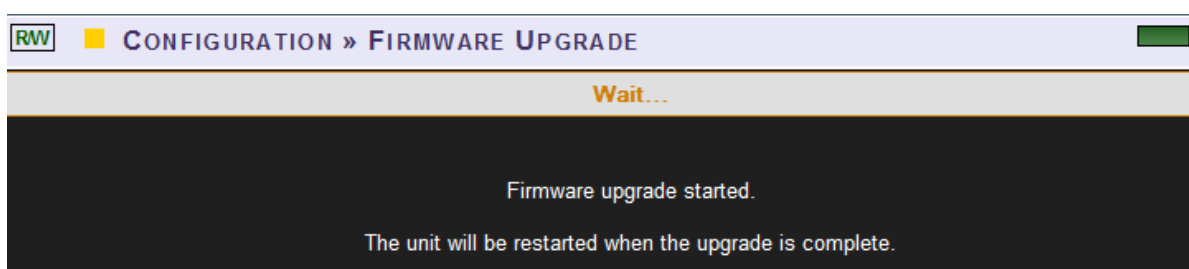

- After the restart & in order to ensure that your changes are applied select [Apply Changes](#)
- In order to refresh your screen & view the changes select [Refresh Data](#)

NOTE NOTE NOTE

If you are not logged on as the Administrator, you will not be able to change any of these settings & you will receive the following error message in your attempt to do so:

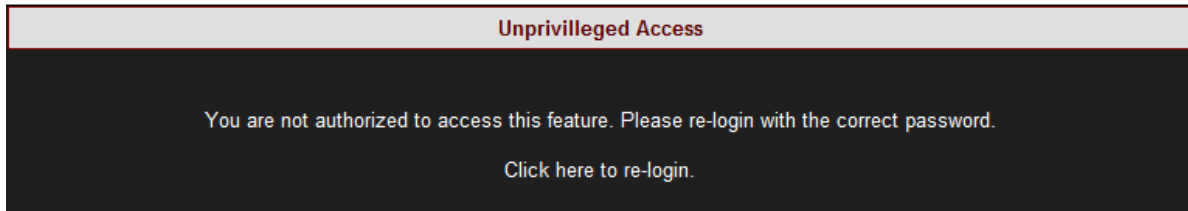

SEE ALSO:

- [About Firmware Upgrade](#)
- [Upgrade - HTTP](#)

Local FW Upgrade

Probably, the simplest way of upgrading your instrument is by using the Local Upgrade functionality.

OPEN THE LOCAL UPGRADE FUNCTIONALITY

- [Access](#) the Portable BLACKBOX via Elspec's Web Interface → log on as the Administrator → select the Configuration Tab → Advanced → Firmware Upgrade Tab
- Go to the Local Image Firmware Upload Section:

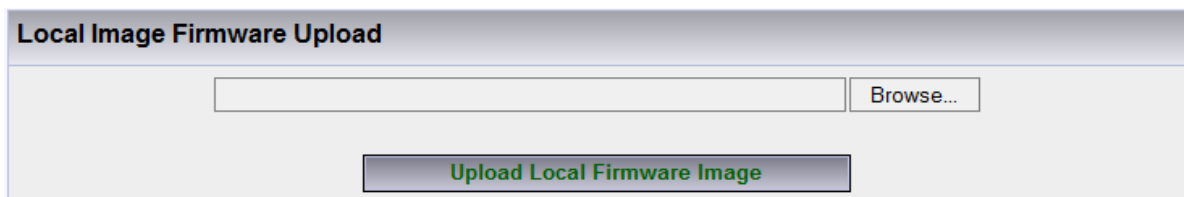

- Select the search for the file on your local computer & select :

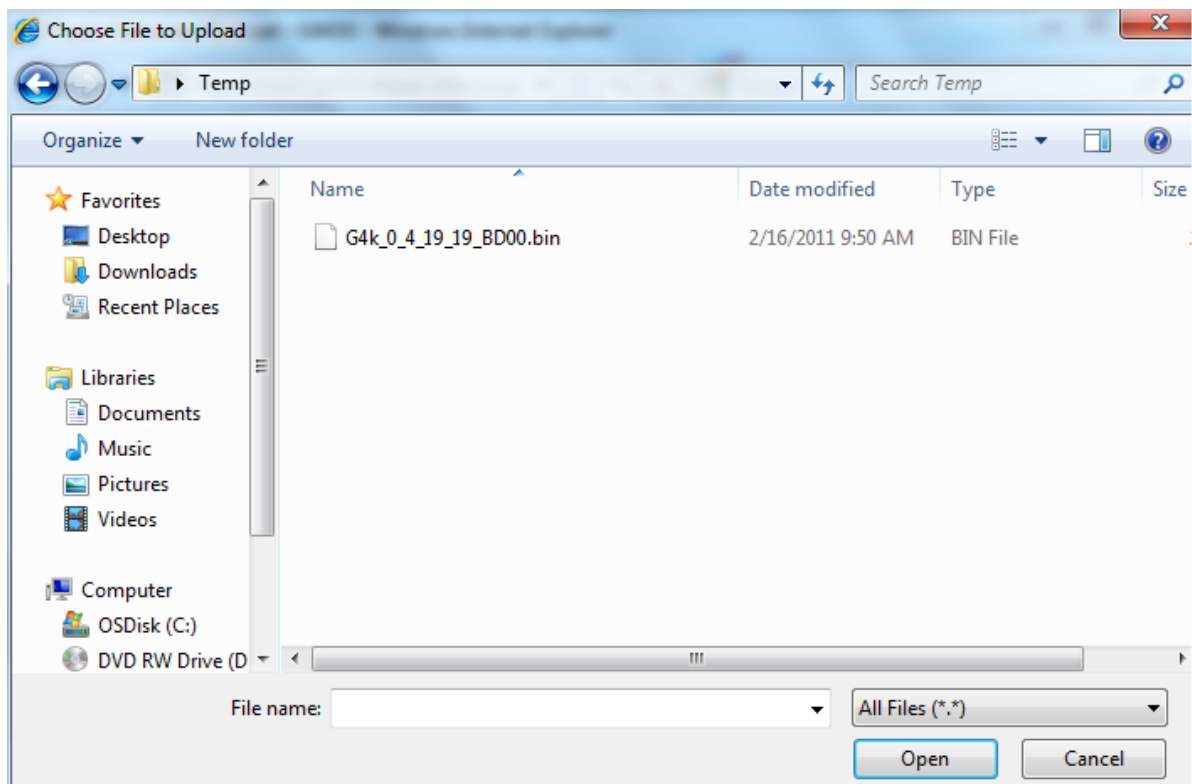

- Select the button to initiate the upgrade process:

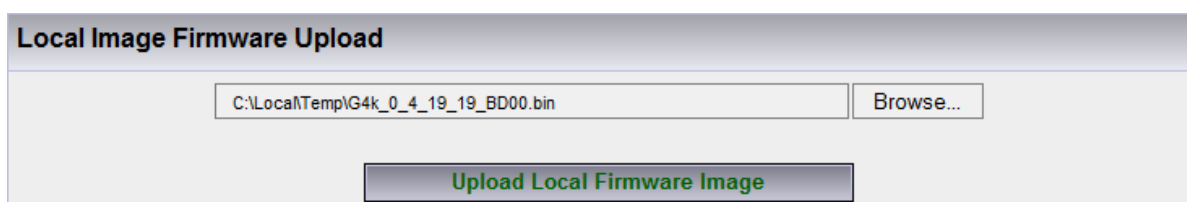

- For your changes to be taken into effect select **Upgrade FW** after which you'll receive a success message & the unit will automatically restart on completion of the upgrade:

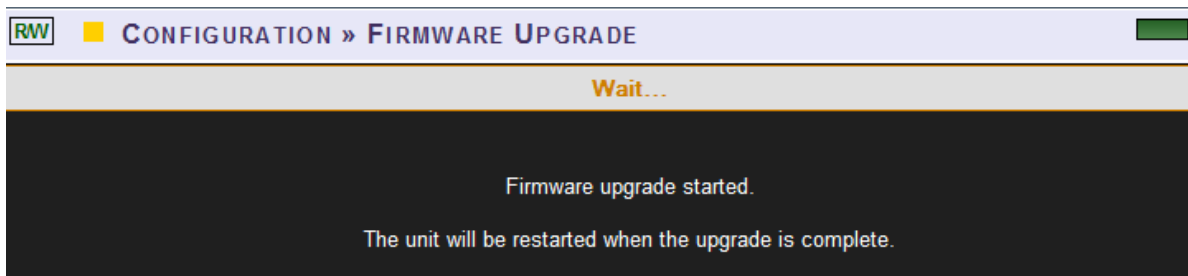

- After the restart & in order to ensure that you are applied select **Apply Changes**
- In order to refresh your screen & view the changes select **Refresh Data**

NOTE NOTE NOTE

If you are not logged on as the Administrator, you will not be able to change any of these settings & you will receive the following error message in your attempt to do so:

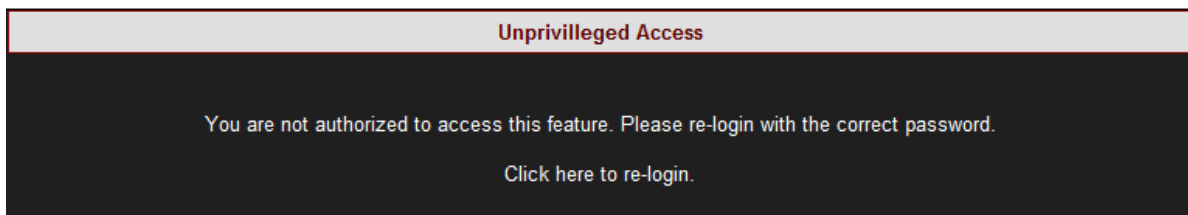

SEE ALSO:

- [About Firmware Upgrade](#)
- [Upgrade - FTP](#)

Other Connections & Settings - About

The Portable BLACKBOX has multiple connections that further extend the monitoring capabilities & portability of the device. In this section you will be able to:

- [Connect & Setup your IO Ports](#)
- [Connect your Communication Ports](#)
- [Replace your Battery](#)
- [Attach the PT100 Temperature Connection](#)
- [Reset Your Portable BLACKBOX](#)

The I/O Ports of the Portable BLACKBOX - Overview

The I/O Ports of the Portable BLACKBOX extends the monitoring capabilities of the device by using additional digital & relay ports. The number of ports is the same for both the G4500 & G3500

There are several types of signals for the Portable BLACKBOX:

- Discrete Digital Input
- Relay
- [Serial Ports - RS232 \(GPS\) & RS485/422](#)

In this Section you will be able to:

- Make the IO Port Connections
- Monitor & Setup the IO Modules

IO Port Connections - About Connecting the IO Ports

As mentioned previously, the number of IO Ports is the same for both the G4500 & G3500 Portable BLACKBOX & they are located on the front of the device.



WARNING

Before you start ensure that the panel is de-energized & that you take the necessary Safety Precautions!

In this section you will be able to:

- [Connect the Digital Input](#)
- [Connect the Relay](#)

Connect the Digital Input

The type of digital input of the G4500/G3500 BLACKBOX is dry contact & the input is capable of several different functions. The digital input can be used to either detect remote signals, or as a pulse counter.

In remote detection the Portable's digital interface is used to sense a "high" or "low" or "false (off)" or "true (on)" state, such as a switch closure. The terms "high" & "low" may refer to the logic level state that a circuit is in when a signal is "true", or "on". For more common purposes the BLACKBOX's digital input signal can be configured when "on" (DI = on/off) it will function (change to 1). For example in a range of motor startups, should the motor fail to start (off) the input signal will change to another state & the G4500/G3500 will perform an action (such as an [E-Mail Notification](#)). Alternatively should the motor start (on) & then fail (off) the input signal will change to another state & the G4500/G3500 will perform any [Pre-Configured Action](#). This can be used in other applications such as in intensity levels temperature, distance, & more. In addition under remote signal detection, the Portable BLACKBOX records input signals & stores it in [PQZIP Files](#). The G4500/G3500 can also be configured to activate many tasks for the [PQZIP Files](#).

In the second application, the digital input of the Portable BLACKBOX is used to count Energy Pulses by means of its internal [Energy meters](#). The sampling rate over the 4 Digital Input Channels is 16 Samples per Cycle at 800Hz @ 50Hz & 960 Hz @ 60Hz.

TYPICAL DIAGRAM OF A DIGITAL INPUT CIRCUIT WITH THE PORTABLE BLACKBOX:

The diagram below outlines a typical Digital Input Circuit with Portable BLACKBOX:

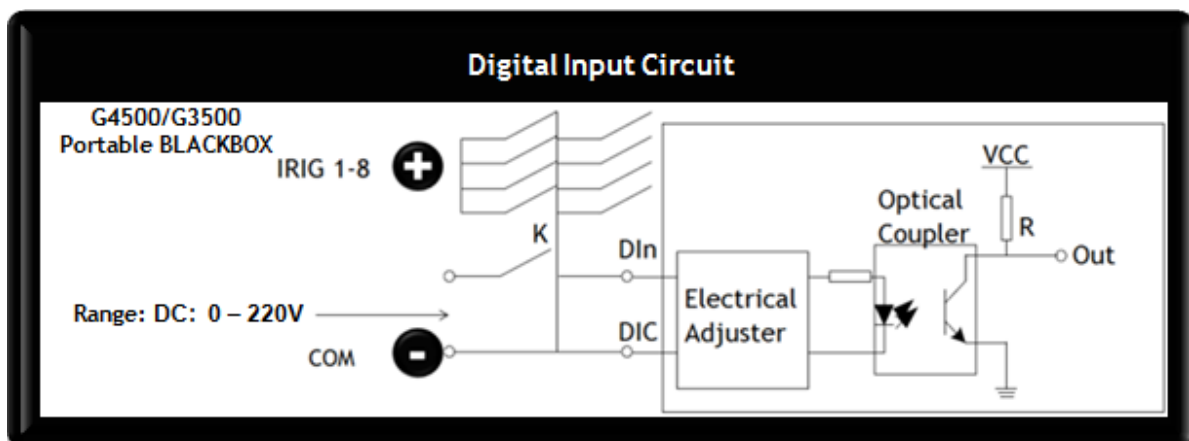

- In the instance when K is Switched OFF, OUT is in High State.
- Should K be Switched ON, OUT is in Low State.
- Select the applicable Auxiliary Power Supply as per outlined Options above.

About the Digital Input Terminal of the Portable BLACKBOX:



Description	Pin Number
Digital Input IRIG B+	1
Digital Input IRIG B-	2
Digital Input 1	3
Digital Input 2	4
Digital Input 3	5
Digital Input 4	6
+5V	V
Common	0
Specifications	
Channels	4
Sampling	800 Hz @ 50Hz (16 Samples per Cycle) 960 Hz @ 60Hz (16 Samples per Cycle)
Range DC:	0 - 220V
Pulse Type	0->1->0, 1->0->1, KYZ
Isolation Connector	125V

SEE ALSO:

- [About Connecting the IO Ports](#)
- [Connect the Relays](#)

Connect the Relay

The relay type (electronic switch) used in the Portable BLACKBOX is C Form. The relay breaks the connection with one throw before making contact with the other (break-before-make). Meaning that the change-over or double-throw contact control two circuits namely: one normally-open contact & one normally-closed contact with a common terminal. In addition it is important to note that the Relay needs to be used with an isolated transformer. There are 3 types of Change Over (C-Form) relays:

- The disable state is the default & disables the relay.
- With the Manual state you can set the "Normally Open Output" as either open / close. This state enables the relay of the device to act as a switch - for example switching a fan on/off should the temperature rise above/below a pre-configured condition.
- In the Automatic state, this will set the relay's output as a function of [Energy](#) / [Events](#) / [Alarms](#).

TYPICAL DIAGRAM OF A RELAY CIRCUIT WITH THE PORTABLE BLACKBOX:

The diagram below outlines a typical Relay Output Circuit with the Portable BLACKBOX:

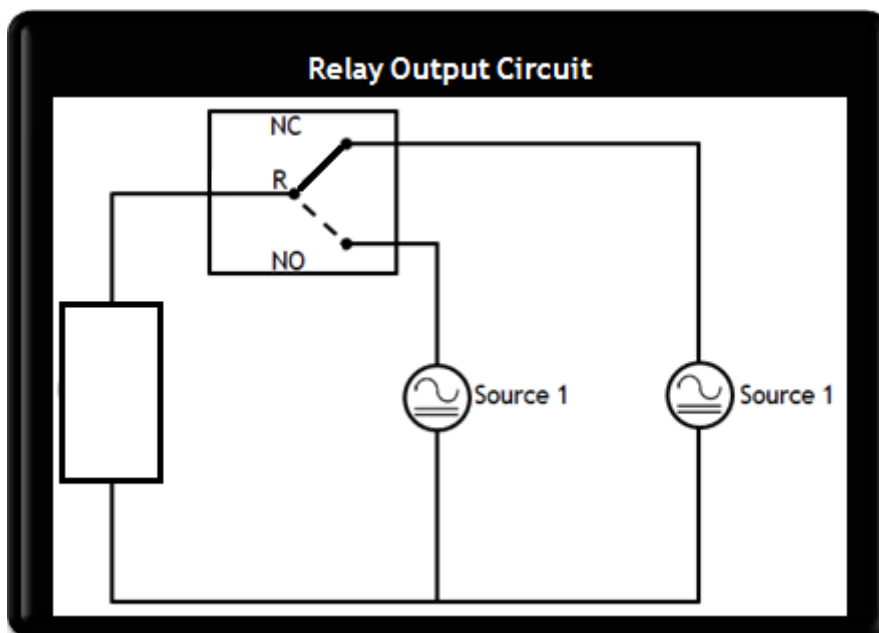

In this example the Relay will control the temperature of the motor:

- Manual State - In the instance "Normally Open" (NO) it will either **Switch On / Off a Fan** (internal / external) on a [pre-configured condition](#).
- Automatic State - In the instance when the Motor over-heats as per a [pre-configured condition](#) "Normally Closed" (NC) will **Signal**, for example, an **Alarm**.
- Disable State - In the instance when Power Supply drops as per a [pre-configured condition](#) the "Relay" (R) will **Disable the Motor**.

- About the Relay Terminal of the Portable BLACKBOX:

	
DESCRIPTION & SYMBOL	PIN NUMBER
Normally Open - NO	1
Relay - R	2
Normally Closed - NC	3
SPECIFICATIONS	
Channels	1 x Change Over
Contact Configuration	1 CO (SPDT - Single Pole Double Throw)
Maximum Switching Voltage	AC: 277V
Maximum Current	AC: 5A/250V; 10A/110V DC: 5A/30V
Maximum Peak Current	15A
Rated Current	6A
Operating Time	4ms
Release Time	6ms
Maximum Reaction Time	10ms
Maximum Drop-Out Time	4ms
Output Resistance	50MΩ

SEE ALSO:

- [About Connecting the IO Ports](#)
- [Connect the Digital Inputs](#)

IO Port Setup - About Monitoring & Setting Up Your IO Ports

The setup configurations & monitoring of all your Portable BLACKBOX'S IO ports are done via the Web Interface. These settings will only appear when you will connect the [Digital Input](#) & [Relay](#). In this section you will be able to:

- [Setup & Monitor the Digital Input Signals](#)
- [Setup & Monitor the Change Over Relay Types](#)

ACCESS THE I/O port MONITORING & CONFIGURATION WINDOWS:

- Access your G4500/G3500 Device via Elspec's Web Interface → log on as the **Administrator** (Manufacturer's Default Password is: 12345) → select the **Multi-IO Tab** (As mentioned above, the Multi-IO tab will only open once the IO Ports are connected):

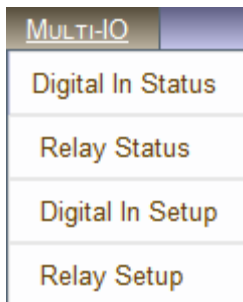

NOTE NOTE NOTE

- If you are not logged on as the **Administrator**, you will not be able to change any of these settings & you will receive the following error message in your attempt to do so:

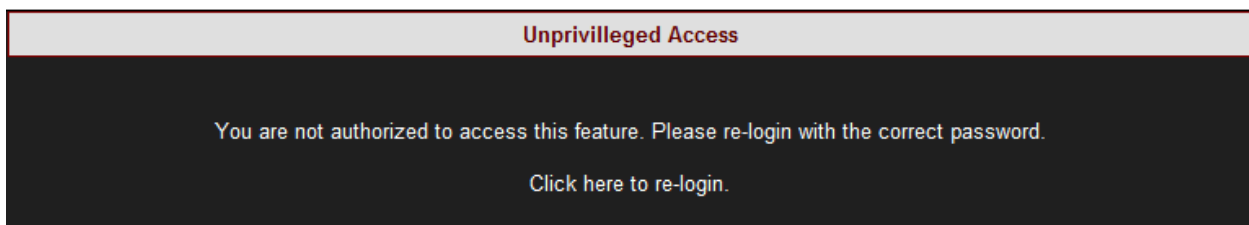

SEE ALSO:

- [Multi IO Overview](#)
- [About Connecting the IO Ports](#)

Digital Input - Setup

The type of digital input of the G4500/G3500 BLACKBOX is dry contact & the input is capable of several different functions. The digital input can be used to either detect remote signals, or as a pulse counter.

In remote detection the Portable's digital interface is used to sense a "high" or "low" or "false (off)" or "true (on)" state, such as a switch closure. The terms "high" & "low" may refer to the logic level state that a circuit is in when a signal is "true", or "on". For more common purposes the BLACKBOX's digital input signal can be configured when "on" (DI = on/off) it will function (change to 1). For example in a range of motor startups, should the motor fail to start (off) the input signal will change to another state & the G4500/G3500 will perform an action (such as an [E-Mail Notification](#)). Alternatively should the motor start (on) & then fail (off) the input signal will change to another state & the G4500/G3500 will perform any [Pre-Configured Action](#). This can be used in other applications such as in intensity levels temperature, distance, & more. In addition under remote signal detection, the Portable BLACKBOX records input signals & stores it in [PQZIP Files](#). The G4500/G3500 can also be configured to activate many tasks for the [PQZIP Files](#).

In the second application, the digital input of the Portable BLACKBOX is used to count Energy Pulses by means of its internal [Energy meters](#). The sampling rate over the 4 Digital Input Channels is 16 Samples per Cycle at 800Hz @ 50Hz & 960 Hz @ 60Hz.

CONFIGURING DIGITAL INPUTS:

- Open the **Multi-IO Tab** & select **Digital In Setup Tab**:

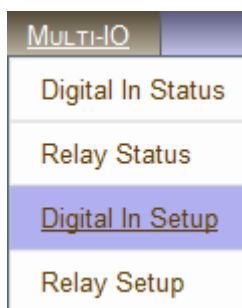

- From the four available digital inputs, choose the one you want to configure. The mode may be configured either as:
 - Disabled Mode:** The Digital Input will be disabled & therefore be inactive
 - Normal Mode:** Input data is sampled & stored in the PQZIP files
 - Di Pulse Mode:** Input data is sampled & stored in PQZIP as in **Normal Mode**. In addition, the number of input pulses are counted inside the unit for the Energy Meter
- When selecting the **Di Pulse Mode**, you need to configure:
 - The Aggregation Factor,
 - The Measuring Unit,
 - The Signal Type, &
 - The minimum time period for the input to remain constant post-changes (Debounce):

RW ■ MULTI-IO » DIGITAL IN SETUP

Digital Inputs Configuration

IO Module: 1 of 1

IRIG-B/PPS Signal status: No Signal

Digital Input 1

Mode: DI Pulse

Counter: 0 Reset

Aggregation Factor: 1

Unit: ▼

kWatth
 KVarh
 KVah
 Km.
 Miles

Signal Type: KYZ

KYZ
 0⇒1⇒0
 1⇒0⇒1

Debounce: 1000 ms

Digital Input 2

Mode: Normal

Logic: 0

Digital Input 3

Mode: Normal

Logic: 0

Digital Input 4

Mode: Normal

Logic: 0

DI Default State

Digital Input	1	2	3	4
Default State	0	0	0	0

TABLE OF DI PULSE MODE CONFIGURATION DESCRIPTIONS:

The table below describes each configuration for the DI Pulse Mode:

DI PULSE MODE CONFIGURATION	DESCRIPTION
Aggregation Factor	The number of pulses = singular (one) unit
Unit	The measuring unit (active energy, reactive energy, apparent energy & distance): <ul style="list-style-type: none"> ▪ kWh: Active Energy ▪ kVarh: Reactive Energy ▪ kVAh: Apparent Energy ▪ Km / Miles: Distance

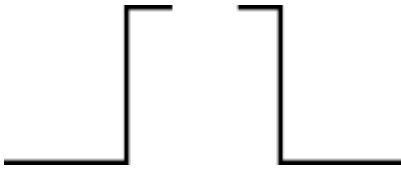
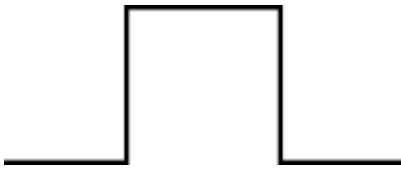
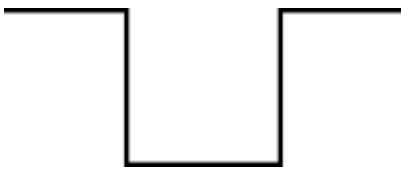
SIGNAL TYPE	
<p>KYZ</p> 	<p>The signal is intermittent, it changes from 0 to 1, or from 1 to 0.</p>
<p>010</p> 	<p>The signal is repetitive & changes from one status to another</p>
<p>101</p> 	<p>A signal is detected when the input Changes from one Status to Another, it Returns to the Original Status (Input starts at 1 changes to 0 & returns to 1)</p>
DEBOUNCE	
<p>Per ms</p>	<p>Configuration to hold the Relay's State for X period for Signal Types outlined above. It is used when lowering time frame between any two samples - i.e.: <1.25msec for a 50Hz Network.</p> <p>The duration is however irrelevant for KYZ Signals since every time the relay state is toggled it remains in that position's state until it is required to toggle again.</p>

CONFIGURING THE DI DEFAULT STATE:

The Discrete Digital Inputs counts the energy pulses that are measured by the Energy Meter. A valid signal will only be detected when the signal will change from the **Default State**, according to the **Defined Pulse Mode** selected (0->1->0; 1->0->1 or KYZ).

- Following the configuration of your Digital Inputs, define the **Default State** for every **Discrete Digital Input line (0 or 1)**:

DI Default State				
Digital Input	1	2	3	4
Default State	0 ▾	0 ▾	0 ▾	0 ▾

0
1

After you have selected & entered the appropriate configurations, select **Reset** for each Digital Input, followed by **Apply Changes** to apply your changes. Click **Refresh Data** to review your changes.

NOTE NOTE NOTE

- You will need to [Enable PQZIP](#) recording in order to set the Digital Inputs. Otherwise you will receive the following message if the PQZIP is Disabled:

Digital In pulsing counter is inactive while PQzip is OFF

- The Portable BLACKBOX will record digital signals according to the system's configurations as per the procedure outlined above. Data monitoring will be in turn based on recorded data.
- If you are not logged on as the **Administrator**, you will not be able to change any of these settings & you will receive the following error message in your attempt to do so:

Unprivileged Access

You are not authorized to access this feature. Please re-login with the correct password.

[Click here to re-login.](#)

SEE ALSO:

- [About Monitoring And Setting Up your IO Ports](#)
- [Digital In Status](#)
- [Relay Setup](#)
- [Relay Status](#)

Digital In Status

The Digital In Status screen will provide you with a summary of all your Portable BLACKBOX's Digital Input settings. In order to access the page:-

- Open the Digital In Status screen by selecting **Multi-IO** ➔ **Digital In Status**:

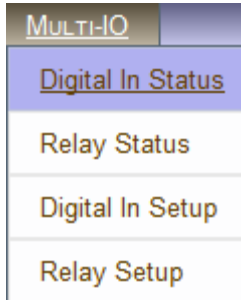

- The **Digital In Status** screen displays the setup status of the **Digital Inputs**:

 A screenshot of the 'MULTI-IO » DIGITAL IN STATUS' screen. At the top, there is a 'RW' icon and a 'MULTI-IO » DIGITAL IN STATUS' breadcrumb. Below this is a 'Digital input Summary' section with 'IO Module: 1 of 1'. A status bar indicates 'IRIG-B/PPS Signal status: No Signal'. The main content is a table with four rows, each representing a digital input with its configuration details.

Digital input Summary		IO Module: 1 of 1
IRIG-B/PPS Signal status: No Signal		
Digital Input 1	Mode: Normal; Logic: 0;	
Digital Input 2	Mode: DI Pulse; Logic: 0; Aggregation Factor: 1; Signal Type: 0⇒1⇒0; Debounce: 1000ms; Aggregated Counter: 0.0000 [kWath] (0 Pulse(s))	
Digital Input 3	Mode: DI Pulse; Logic: 0; Aggregation Factor: 1; Signal Type: KYZ; Debounce: 1000ms; Aggregated Counter: 0.0000 [] (0 Pulse(s))	
Digital Input 4	Mode: Normal; Logic: 0;	

DESCRIPTIONS OF THE DIGITAL INPUT SUMMARY WINDOW:

STATUS	DESCRIPTION
IRIG-B/PPS	Input is currently inactive
Digital Input 1	Disabled
Digital Input 2	Configured to Normal Mode & the State is Open
Digital Input 3	Configured to DI Pulse Mode, whereas Each Pulse = 1 Unit, using KYZ as a Pulse Type, & Debounce = 1000 ms
Digital Input 4	Disabled

SEE ALSO:

- [About Monitoring And Setting Up your IO Ports](#)
- [Digital In Setup](#)
- [Digital In Status](#)
- [Relay Setup](#)
- [Relay Status](#)

Relay - Setup

The type of relay (electronic switch) used in the Portable BLACKBOX are **C Form**. The relay break the connection with one throw before making contact with the other (break-before-make). Meaning that the change-over or double-throw contacts control two circuits namely: one normally-open contact & one normally-closed contact with a common terminal. There are 3 types of change over relays:

- The disable state is the default & disables the relay.
- With the Manual state you can set the "Normally Open Output" as either open / close. This state enables the relay of the device to act as a switch - for example switching a fan on/off should the temperature rise above/below a pre-configured condition.
- In the Automatic state, this will set the relay's output as a function of [Energy](#) / [Events](#) / [Alarms](#).

SETTING UP THE RELAY:

- [Open](#) the **Multi-IO Tab** & select **Relay Setup Tab**:



- Select the applicable **Mode** for each Relay:

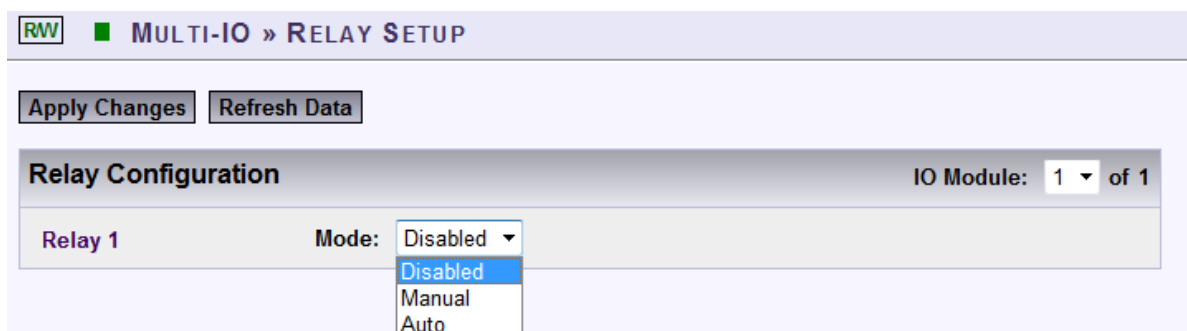

Modes:

- **Disabled:** Default state - **disables** this specific relay
- **Manual:** Sets the static output for this relay either '0' or '1'
- **Auto:** To build a conditional output for the relay

MANUAL MODE:

- By selecting the **Manual Mode**, the relay's **Normally Open Output** can be set either as **Open (0)** or **Closed (1)**:

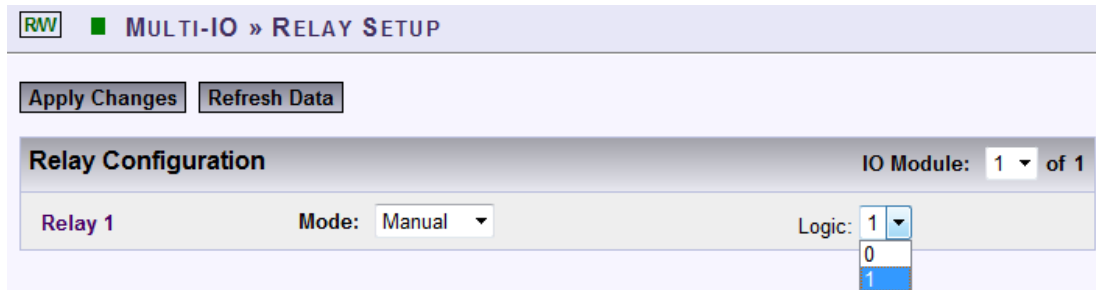

The screenshot shows the 'MULTI-IO » RELAY SETUP' page. At the top, there are 'Apply Changes' and 'Refresh Data' buttons. Below is the 'Relay Configuration' section for 'IO Module: 1 of 1'. For 'Relay 1', the 'Mode' is set to 'Manual'. A 'Logic' dropdown menu is open, showing options '1', '0', and '1', with '1' selected.

AUTO MODE:

- By selecting the **Auto Mode**, the relay's **Output** will trigger on the following **Functions**:
 - [Energy Signal](#)
 - [Events Signal](#)
 - [Alarm Signal](#)

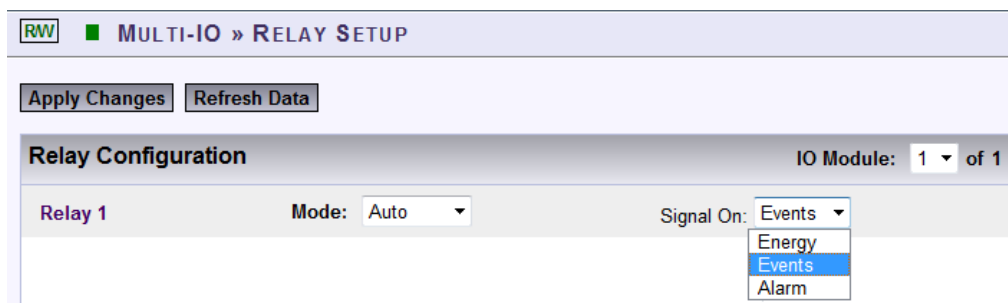

The screenshot shows the 'MULTI-IO » RELAY SETUP' page. At the top, there are 'Apply Changes' and 'Refresh Data' buttons. Below is the 'Relay Configuration' section for 'IO Module: 1 of 1'. For 'Relay 1', the 'Mode' is set to 'Auto'. A 'Signal On' dropdown menu is open, showing options 'Events', 'Energy', 'Events', and 'Alarm', with 'Events' selected.

NOTE NOTE NOTE

If you are not logged on as the Administrator, you will not be able to change any of these settings & you will receive the following error message in your attempt to do so:

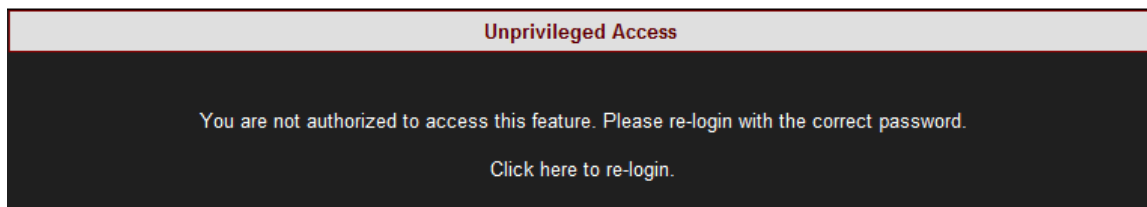

SEE ALSO:

- [About Monitoring And Setting Up your IO Ports](#)
- [Digital In Setup](#)
- [Digital In Status](#)
- [Relay Status](#)

Event Signal

In this section you will configure the type of **Event Signal** that is going to trigger the relay's output.

CONFIGURE THE TYPE OF EVENT SIGNAL:

- [Open](#) the **Multi-IO Tab** & select **Relay Setup Tab**
- The Event Signal's configuration needs to be based on (See the table of definitions for your settings):
 - Event Class (PQ Events & Custom Events),
 - Signal Type,
 - Trigger Type,
 - Custom Event / PQ Event (When applicable Event Class has been selected) &
 - Duration of the signal:

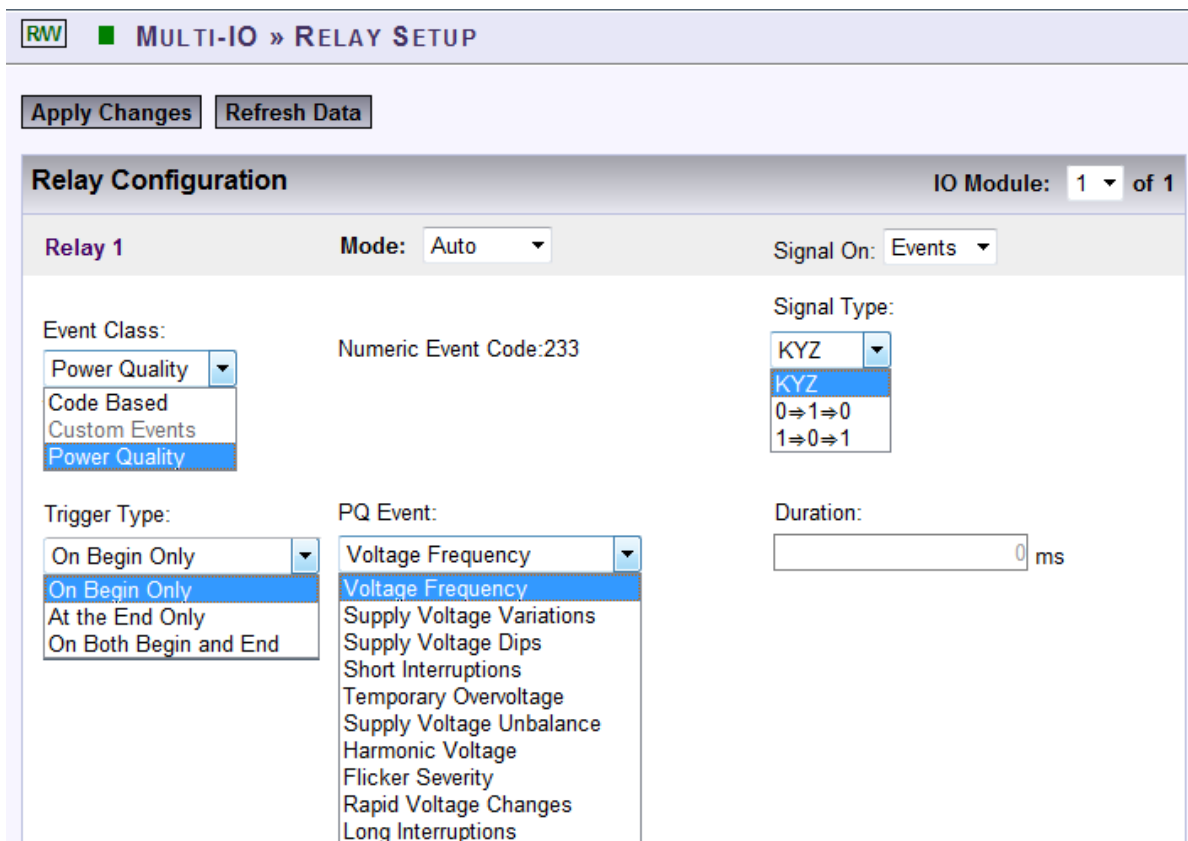

RW ■ MULTI-IO » RELAY SETUP

Apply Changes **Refresh Data**

Relay Configuration IO Module: 1 of 1

Relay 1 Mode: Auto Signal On: Events

Event Class: Power Quality Numeric Event Code: 233 Signal Type: KYZ

Code Based
Custom Events
Power Quality

Trigger Type: On Begin Only PQ Event: Voltage Frequency Duration: 0 ms

At the End Only
On Both Begin and End

Supply Voltage Variations
Supply Voltage Dips
Short Interruptions
Temporary Overvoltage
Supply Voltage Unbalance
Harmonic Voltage
Flicker Severity
Rapid Voltage Changes
Long Interruptions

TABLE OF EVENT SIGNAL TYPES:

The table below describes each configuration:

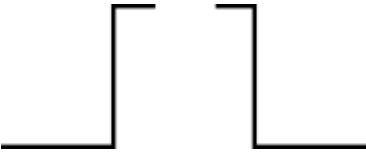
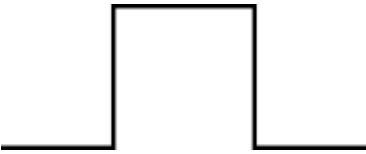
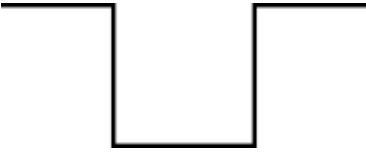
EVENT SIGNAL	DESCRIPTION
PULSE WEIGHT	
Code Based	The Relay signal can be set to perform based on the Event Codes of the Portable unit. This option is for internal use only at this time.
Custom Events	Custom events are uniquely defined by the user. Ensure that you Configure your Custom Event , prior to selecting this option for the relays to trigger on the occurrence of the event. In total you may uniquely configure up to 32 Customized Events.
Power Quality	The Relay is triggered in accordance to the Compliance Configuration of your device.
SIGNAL TYPE	
KYZ 	Changes the state of the relay (Toggle) - If the Normally Open contact is Closed it will switch to Open and if it is Open it will switch to Closed .
0⇒1⇒0 	The steady state of the Relay is “ Not Energized ”, meaning that the Normally Open terminal is Open . Once this output signal commences, the relay will close its Normally Open terminal for a predefined period and then return to the initial state (where the “ Normally Open ” terminal returns to “ Open ”). The period of time the Relay will stay Energized is set by the “ Duration ” parameter under the Relay Setting field of that particular relay.
1⇒0⇒1 	In this case, the Steady State of the Relay is “ Energized ”. The “ Normally Open ” terminal of the relay is Constantly Closed . Once the output signal commences, the Relay will Open its “ Normally Open ” terminal for a predefined period and then return to the initial state (where “ Normally Open ” terminal is closed). The period of time the Relay will stay energized is set by the “ Duration ” parameter under the Relay Setting field of that particular relay.

TRIGGER TYPE	
On the Begin Only	The Relay signal is synchronized to begin at the time the Event Condition Begins .
At the End Only	The Relay signal is synchronized to begin at the time the Event Condition Ends .
On Both Begin and End	The Relay signal is synchronized to begin at the time the Event Condition Begins & begin again at the time the Event Condition Ends .
DURATION	
per ms	Configuration to hold the Relay's State for X period for Signal Types outlined above. The duration is irrelevant for KYZ Output Signals since every time the relay state is toggled it remains in that position's state until it is required to toggle again.

- After you have selected & entered the appropriate configurations, select [Apply Changes](#) to apply your changes → [Refresh Data](#) to review your changes

NOTE NOTE NOTE

If you are not logged on as the Administrator, you will not be able to change any of these settings & you will receive the following error message in your attempt to do so:

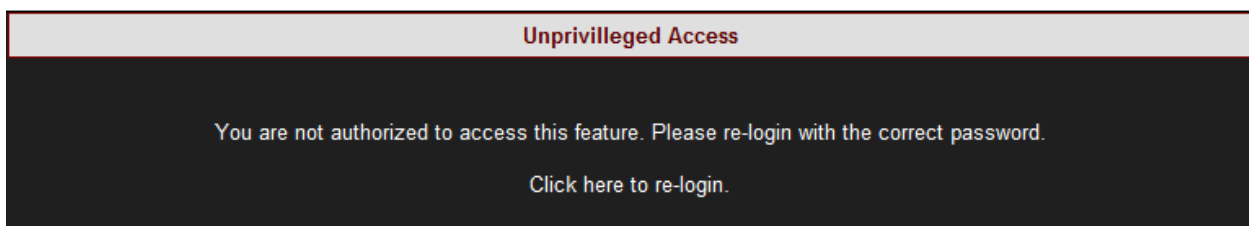

SEE ALSO:

- [About Monitoring And Setting Up your IO Ports](#)
- [Digital In Setup](#)
- [Digital In Status](#)
- [Relay Setup](#)
- [Energy Signal](#)
- [Alarm Signal](#)
- [Relay Status](#)

Energy Signal

In this section you will configure the type of **Energy Signal** that is going to trigger the relay's output.

CONFIGURE THE TYPE OF ENERGY SIGNAL:

- [Open](#) the **Multi-IO Tab** & select **Relay Setup Tab**
- Select **Auto Mode** for the **Applicable Relay** that you want to configure ➔ select **Signal On Energy**:
- The Energy Signal's configuration needs to be based on:
 - Pulse Weight (by quantity & parameter),
 - Signal Type, &
 - Duration of the signal:

RW ■ MULTI-IO » RELAY SETUP

Apply Changes Refresh Data

Relay Configuration

IO Module: 1 of 1

Relay 1

Mode: Auto

Signal On: Energy

Pulse Weight:

0.01

- 0.01
- 0.025
- 0.05
- 0.1
- 1
- 10
- 100
- 1000
- 10000
- 100000
- 1000000

Wh In

- Wh In
- Wh Out
- VAh
- VArh In
- VArh Out

Signal Type:

KYZ

- KYZ
- 0⇒1⇒0
- 1⇒0⇒1

Duration:

ms

TABLE OF ENERGY SIGNAL TYPES:

The table below describes each configuration:

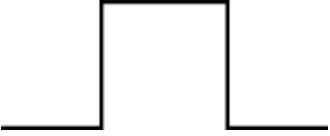
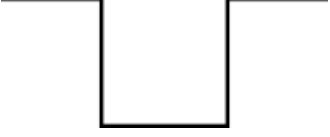
ENERGY SIGNAL	DESCRIPTION
PULSE WEIGHT	
Quantity	The amount of energy (quotient) for which a pulse is generated (Every time another energy quotient is measured - a preset number of pulses is generated). Select the appropriate value - from 0.01 to 100000
Parameter	<ul style="list-style-type: none"> ▪ Wh In: Active Energy flowing from Utility to Customer ▪ Wh Out: Active Energy flowing from Customer to Utility ▪ VAh: Total Energy measured by the Meter ▪ VARh In: Reactive Energy flowing from Utility to Customer ▪ VARh Out: Reactive Energy flowing from Customer to Utility
SIGNAL TYPE	
KYZ 	Output toggles its current state
0⇒1⇒0 	The Relay changes its output status from the Steady Position (Open) to Closed , holds this state for a predefined period of time (as per Duration parameter set below) & then reverts to its Original State (Open)
1⇒0⇒1 	The Relay's Steady Position is Closed . For this signal type the Relay changes it's state to Open , holds this state for a predefined period of time (as per Duration parameter set below) & then reverts to its original status back to Closed
DURATION	
per ms	Configuration to hold the Relay's State for X period for Signal Types outlined above. The duration is irrelevant for KYZ Output Signals since every time the relay state is toggled it remains in that position's state until it is required to toggle again

- After you have selected & entered the appropriate configurations, select [Apply Changes](#) to apply your changes → [Refresh Data](#) to review your changes

NOTE NOTE NOTE

If you are not logged on as the Administrator, you will not be able to change any of these settings & you will receive the following error message in your attempt to do so:

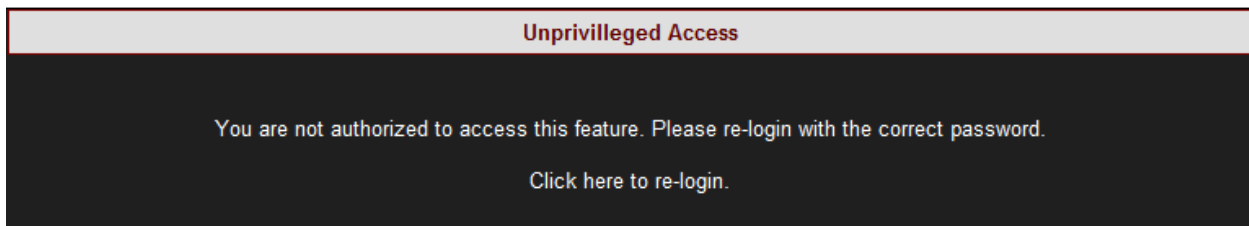

SEE ALSO:

- [About Monitoring And Setting Up your IO Ports](#)
- [Digital In Setup](#)
- [Digital In Status](#)
- [Relay Setup](#)
- [Event Signal](#)
- [Alarm Signal](#)
- [Relay Status](#)

Alarm Signal

The **Alarm Signal** function allows the conditioning of the **Relay Output Signal** on the internal alarm of the Portable BLACKBOX unit. There is only one Alarm code available at this time; the one that lights the **RED** light on the Panel:



CONFIGURE THE RELAY BASED ON AN ALARM SIGNAL:

- [Open](#) the **Multi-IO Tab** & select the **Relay Setup Tab**
- Select **Auto Mode** for the **Applicable Relay** that you want to configure ➔ select **Signal On Alarm**:
- The Alarm Signal's configuration needs to be based on:
 - Alarm Type, &
 - Parameter Code:

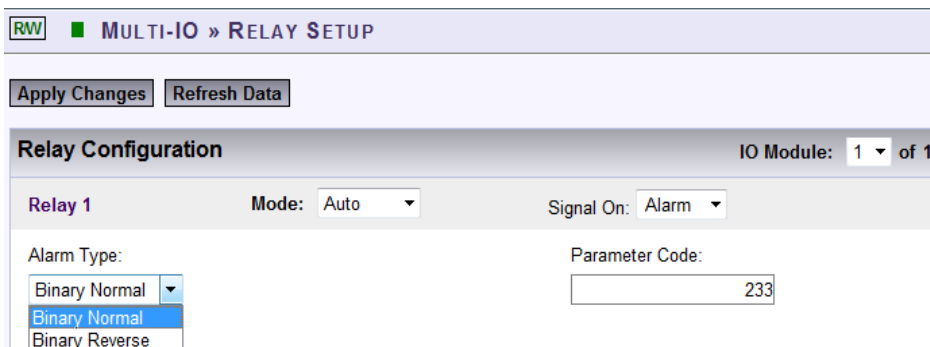

The screenshot shows the 'MULTI-IO » RELAY SETUP' configuration page. It includes buttons for 'Apply Changes' and 'Refresh Data'. Under 'Relay Configuration', 'IO Module' is set to '1 of 1'. For 'Relay 1', the 'Mode' is 'Auto' and 'Signal On' is 'Alarm'. The 'Alarm Type' dropdown is open, showing 'Binary Normal' (selected), 'Binary Normal', and 'Binary Reverse'. The 'Parameter Code' field contains the value '233'.

TABLE OF ALARMS:

ALARM SIGNAL	DESCRIPTION
ALARM TYPE	
Binary Normal	This means that should the value (Alarm Flag) of the alarm be 0 then the output is 0 (Relay is Not Energized) & should the value (Alarm Flag) of the alarm be 1, then the output is 1 (Relay is Energized) .
Binary Reverse	This means that should the value (Alarm Flag) of the alarm be 0 , the output is 1 (Relay Channel is Energized) and should the value (Alarm Flag) be 1 , the output is 0 (Relay is Not Energized) .
PARAMETER CODE	
233	Currently there is only one alarm parameter called "General Status" which is also represented by illuminating a red Indication Light on the front of the

Portable BLACKBOX (as per figure above). Its Parameter Code is **233**.

- After you have selected & entered the appropriate configurations, select **Apply Changes** to apply your changes → **Refresh Data** to review your changes

NOTE NOTE NOTE

If you are not logged on as the Administrator, you will not be able to change any of these settings & you will receive the following error message in your attempt to do so:

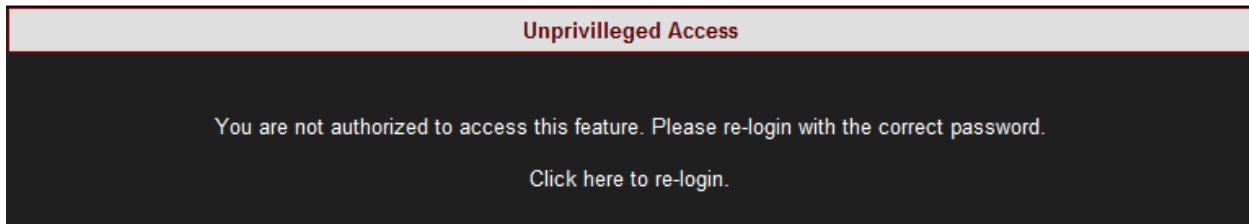

SEE ALSO:

- [About Monitoring And Setting Up your IO Ports](#)
- [Digital In Setup](#)
- [Digital In Status](#)
- [Relay Setup](#)
- [Event Signal](#)
- [Energy Signal](#)
- [Relay Status](#)

Relay Status

The Relay Status screen displays the setup status of the Relays. In order to access the page:-

- [Open](#) the screen by selecting **Multi-IO** ➔ **Relay Status**:

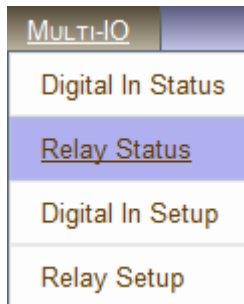

- The **Relay Status Screen** displays the setup status of the relays:

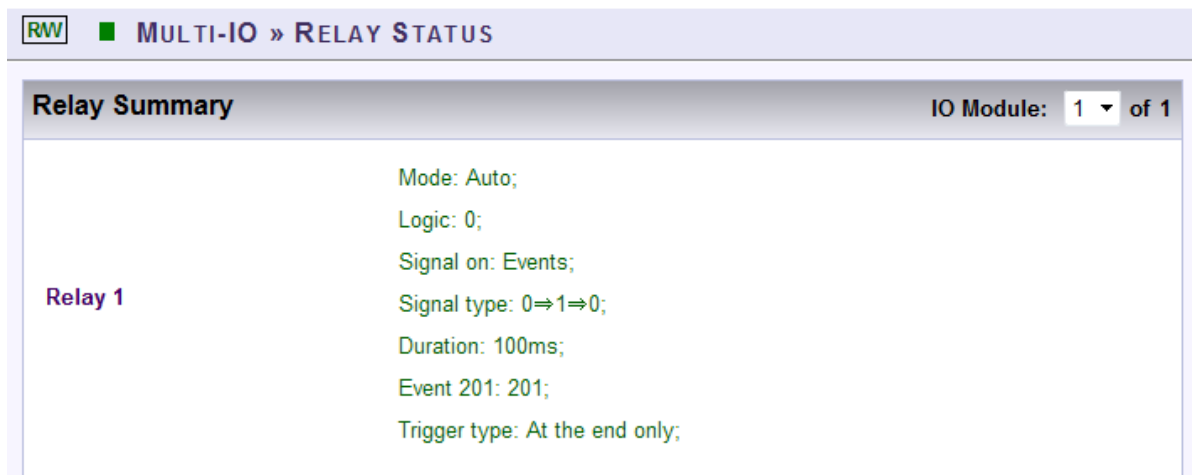

Definition of the Relay configuration:

Relay 1	Configured to Auto Mode , signaled on Events , using 0->1->0 as the Signal Type for a Duration of 100ms . Relay signal is synchronized to Begin at the time the Condition Ends .
----------------	--

SEE ALSO:

- [About Monitoring And Setting Up your IO Ports](#)
- [Digital In Setup](#)
- [Digital In Status](#)
- [Relay Setup](#)
- [Event Signal](#)
- [Energy Signal](#)
- [Alarm Signal](#)

Communication Ports - About Connecting The Ports

The Portable BLACKBOX has various communication gateways & ports allowing for quick portable access, over any network from any location. As mentioned previously, the only difference between the two devices lies in the number of communication ports of the G4500 & G3500 Portable BLACKBOX, and how they are subsequently [configured](#). In addition to the [Wi-Fi Communication](#), the G4500 has 3 communication ports including two isolated serial communication RS232 & RS485/422 ports. The G3500 hosts 1 LAN communication port including two serial ports RS232 & RS485/422.

In this section you will be able to:

- [Connect the LAN Ports](#)
- [Connect the Serial Ports](#)
- For Wireless Communication See: [Wi-Fi Connectivity](#)

SEE ALSO:

- [About BLACKBOX's Communication Configuration](#)
- [Security](#)
- [Network](#)
- [Serial Ports](#)

Connect The LAN Ports

The illustrations below will provide a graphic presentation of all the possible LAN connections for the Portable BLACKBOX:

G4500 LAN CONNECTIONS:

The Ethernet ports of the G4500 have been designed to serve an intended purpose. For instance, do not connect the G4500 to the office network via the LAN 1 port, since an Office DHCP server operation could be interrupted which could lead to severe network malfunctions. Refer to [Network Setup](#) for your network configurations.

- Before you start ensure that you take the necessary [Safety Precautions](#) & that you have all the [Accessories](#) & [Tools](#) you'll need
- As per the illustrations simply connect the LAN cable to the applicable intended port:

WIFI OR LAN 1 CONNECTIONS:

The Illustration below illustrates either a Wi-Fi connection or a LAN 1 connection. LAN 1 is an alternative means of establishing communication with G4500 if you are unable to make a Wi-Fi connection. Use the Wi-Fi & LAN 1 port for connecting the G4500 Portable BLACKBOX with Elspec's G4150 Mobile Analysis, or a PC, or a Laptop.

You can read all about wireless connection in [Wi-Fi Connectivity](#).



WAN CONNECTION:

The WAN port serves to connect the device's internal LAN with other types of networks. It is commonly used to provide internet accessibility over an external Broadband router (Cellular, ADSL or Cable). When connected to an Office network, it most likely already employs a DHCP server. The WAN & LAN 2 Ports are the ideal ports for connecting to the DHCP Server. Do not connect your Portable BLACKBOX to the office network via the LAN 1 port, since an Office DHCP server operation could be interrupted which could lead to severe network malfunctions.

See [WAN Internet Accessibility](#) for network configurations. Illustration:

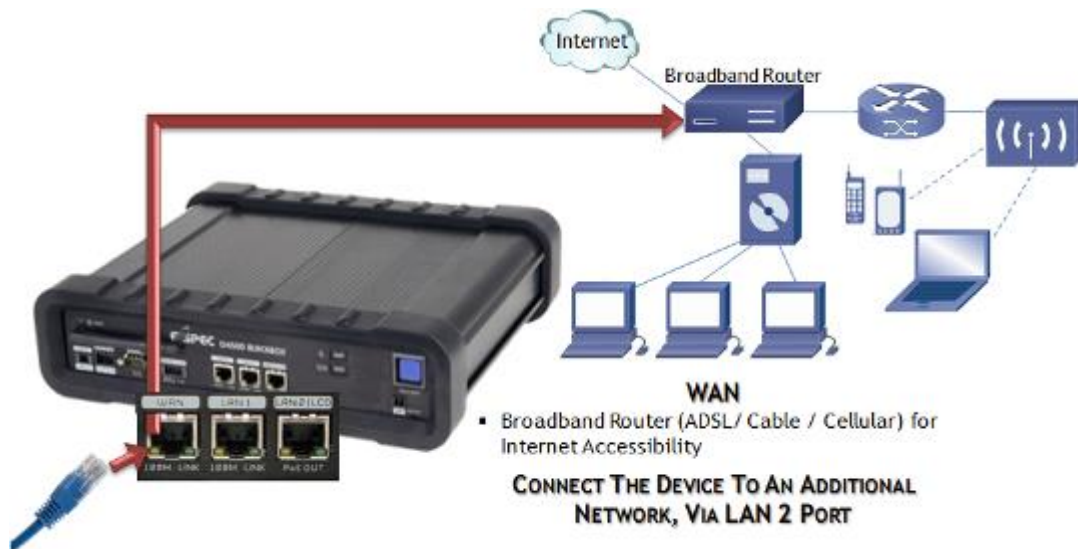

LAN 2 CONNECTION:

The port is mainly used to connect the device to a LAN network of computers or an additional network other than the WAN connection.

See [LAN 2](#) for network configurations. Illustration:



G3500 LAN CONNECTION:

The G3500 Portable BLACKBOX has only one LAN port & this is the main connection port for either the G4150, or DHCP, or PC, or Laptop, or LAN Network of Computers or the G4100 Remote Display Unit.

- Before you start, ensure that you take the necessary [Safety Precautions](#) & that you have all the [Accessories](#) & [Tools](#) you'll need
- As per the illustration simply connect the LAN cable to the applicable intended port:

LAN / LCD (Main Port)

- G4150 / PC / Laptop
- OR
- DHCP
- OR
- LAN Network of Computers
- OR
- G4100



SEE ALSO:

- [About BLACKBOX's Communication Configuration](#)
- [Security](#)
- [Network](#)
- [Serial Ports](#)

Serial Port Connections

The Portable BLACKBOX is equipped with 2 isolated Serial Communication interfaces, namely the RS232 & RS485/422. The RS232 is used for interfacing with a GPS & the RS485/422 for PPP & TTY communication protocols. Both ports are located on the front of the G4500/G3500 Portable BLACKBOX. See [Serial Ports](#) for configuring the serial communication of your BLACKBOX.

CONNECTING THE RS232 WITH THE GPS:

The RS232 is a standard DTE (Data Terminal Equipment) interface suitable for direct communication with a GPS. The unique time synchronization algorithm of the BLACKBOX device series presents the highest level availability of time, with an accuracy of 100-200 μ s for both SNTP & GPS. To configure the GPS see [GPS Configuration](#) & for SNTP Network see [Network Time](#). As with the other connections with the Portable BLACKBOX, the GPS is no exception & as per the illustration the procedure is quick & easy to follow for both the G4500 & G3500:

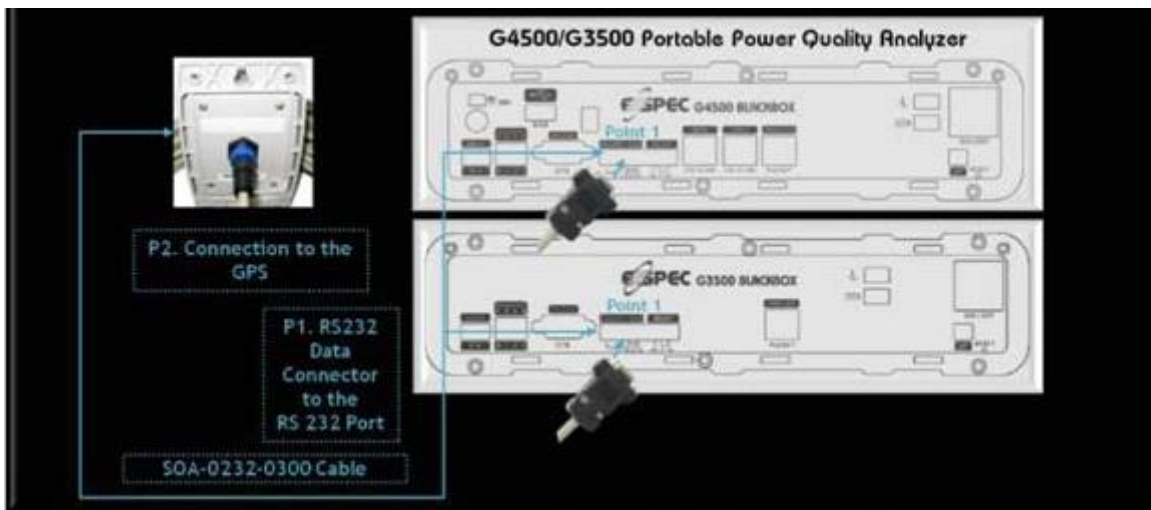

- Ensure that you take the necessary [Safety Precautions](#) & that you have all the [Accessories](#) & [Tools](#) you'll need
- Simply connect & secure the RS232 Data Connector the RS232 Port on the Portable BLACKBOX (Point 1)
- Secure the GPS connection end to the GPS (Point 2)

About the R232 connection:

DTE - Data Terminal Equipment	
SYMBOL & DESCRIPTION	
SYMBOL & DESCRIPTION	PIN NUMBER
DCD - Data Carrier Detect	1
RDx - Receive Data (Input)	2
TDx - Transmit Data	3
DTR - Data Terminal Ready	4
SG - Signal Ground	5
DRS - Data Ready State	6
RTS - Request To Send	7
CTS - Clear To Send	8
RI - Ring Indicator	9
SPECIFICATIONS	
Default Configuration Baud Rate	19200, Data Bits: 8 , Parity: None, Stop Bits: 1
Communication Protocols	GPS
Duplex	Full
Maximum Cable Length	15.2m (50')

CONNECTING THE RS485/422:

A standard RS485 (full duplex) or RS422 (half duplex) interface, it mainly supports PPP & TTY communication protocols. In order to configure the RS485/422 communication see [SNTP Network](#) see [RS-485/ RS-422](#) & [PPP Configurations](#). Once again as illustrated the connection procedure is quick & easy to follow for both the G4500 & G3500:

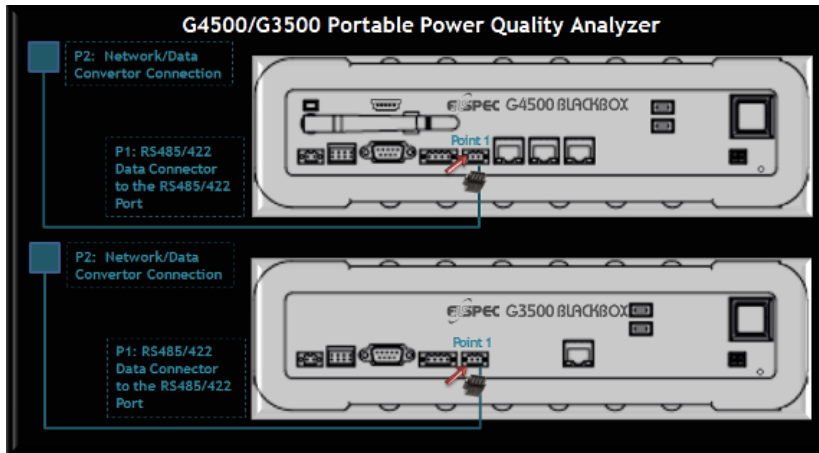

- Ensure that you take the necessary [Safety Precautions](#) & that you have all the [Accessories](#) & [Tools](#) you'll need
- Simply connect & secure the RS485/422 Data Connector the RS485/422 Port on the Portable BLACKBOX (Point 1)
- Secure the opposite end to the appropriate Network / Data Converter (Point 2)

About the RS482/422 connection:



SPECIFICATIONS

Baud Rate	Configurable: 1200 / 2400 / 4800 / 9600 / 14400 / 19200 / 38400 57600 / 115200
Communication Protocols	PPP & TTY
Duplex	Full
Maximum Cable Length	15.2m (50')

SEE ALSO:

- [About BLACKBOX's Communication Configuration](#)
- [Security](#)
- [Network](#)
- [Serial Ports](#)

Battery Replacement

The BLACKBOX Portable is equipped with an internal lithium battery that will allow you to operate the BLACKBOX for up to 2 hours without having to connect to either an AC/DC external power source. The battery requires no maintenance whatsoever & is designed for a long-life service.

However, should the battery's performance decrease significantly, it will need to be replaced with an original component that can be either ordered directly from Elspec or, from your local Elspec Agent. Before you start, ensure that you [Take the Necessary Safety Precautions](#) & [Ensure Your Have All the Tools You Will Need for Changing the Battery](#).

VERIFY THE BATTERY'S OPERATION VIA POWER SUPPLY INDICATORS:





Flashing Blue	Main Auxiliary Power Applied, Battery Charging	
Solid Blue	Main Auxiliary Power Applied, Battery Fully Charged	

In this section you will be able to:

- [Remove the Malfunctioned Battery](#)
- [Install the New Battery & Verify Operation](#)

Remove The Malfunctioned Battery

Ensure you Have all You Need & have taken the necessary Safety Precautions.

<ul style="list-style-type: none"> Remove the Rubber Cover from the Front Panel: 	
<ul style="list-style-type: none"> Remove all screws from the Front Panel (6 x Flat & 2 x Phillips Screws): 	
<ul style="list-style-type: none"> Remove the Front Panel with the Bracket at a straight angle (as not to damage the antenna): 	
<ul style="list-style-type: none"> Remove the Battery Connector from the device terminal located on the front: 	
<ul style="list-style-type: none"> Remove the Battery from the Battery Housing: 	





Proceed to the [Next Step - Battery Replacement](#)

SEE ALSO:



- [About Battery Replacement](#)
- [G3500 BLACKBOX Unit](#)
- [G4500 BLACKBOX Unit](#)

Replace The New Battery

After you have [Removed the Malfunctioned Battery](#), you can now proceed to replace it:

<ul style="list-style-type: none"> Place the New Battery in the Battery Housing: 	
<ul style="list-style-type: none"> Reconnect the Plug Connector from the battery to the Terminal Inside the Device. Ensure that the wires are properly tucked into the housing: 	
<ul style="list-style-type: none"> Replace the Front Panel & re-secure the screws. Replace the Rubber Cover. Re-connect all the Power & Communication Cables. 	
<ul style="list-style-type: none"> On the Front Panel turn on the Main Power Supply Switch to the ON position: 	

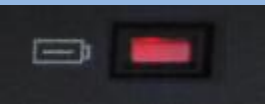
VERIFY OPERATION VIA INDICATORS

Flashing Blue	Main Auxiliary Power Applied, Battery Charging	
Solid Blue	Main Auxiliary Power Applied, Battery Fully Charged	
Red	No main or auxiliary power available/Powered by internal battery	

SEE ALSO:

- [About Battery Replacement](#)
- [Safety Precautions](#)
- [What You'll Need](#)
- [G3500 BLACKBOX Unit](#)
- [G4500 BLACKBOX Unit](#)

Attach The PT100 Temperature Connection (Optional)

The Portable BLACKBOX is equipped with an optional external connection terminal for a PT100 Temperature Sensor. There are two additional internal temperature sensors namely PSU & DSP, which will record temperature readings during the entire measurement session - See [Monitoring Real Time Temperature Data](#). Attachment procedure for the external PT100 Temperature Sensor:

- Remove the [PT100 Temperature Sensor](#) provided with the Portable BLACKBOX unit:



- Connect the sensor to the front of the device:



SEE ALSO:

- [Reset Your Portable BLACKBOX](#)

Reset Your Portable BLACKBOX

The Reset Button serves mainly two purposes:

- To Restore all the Default Factory Settings: Meaning that all the configurations that have been set for the device will be deleted & returned to the factory defaults. This includes Disabling the PQZIP Recording.
- Verify that LED Signals are operating & functioning properly

RESET THE PORTABLE BLACKBOX

- Ensure that the Portable BLACKBOX is switched ON and that Operational Status Indicator should be either solid blue or red
- Access the reset button with either a sharp instrument or a small screwdriver:



- Press and hold the reset button
- After 5 seconds all the LEDs will turn ON. At that stage you may inspect the LED Signals & check that they are working
- After another additional 8 seconds the Portable BLACKBOX will reboot & restore all factory default settings.

SEE ALSO:

- [Attach Temperature Connection](#)

Elspec Search Utility - About

Elspec's Search Utility is a small, yet powerful tool that allows searching for multiple G4K BLACKBOX device IP addresses sharing the same local LAN. The Elspec Search makes use of UDP broadcasting, sending a “please respond” broadcast request to all devices on the LAN and displaying the resultant list of all devices responding to it.

When a [1st Time Connection has been Established](#) between a unit and the host computer, the internal Web Interface can be accessed most commonly using the **Search Utility**, or by typing the IP address (if known) directly into the address field of the **Internet Web Browser**. This Web interface is designed to serve as the main user interface with the instrument, providing enhancement, configuration, & real-time monitoring functionality.

NOTE NOTE NOTE

- The Website is optimized to work with Internet Explorer 7, 8 or 9 in “Compatibility View”. Ensure that the Internet Explorer is running in **Compatibility View**:



- For local networking the browser should be configured as working without a proxy server. Refer to Disable Proxy Server in Internet Explorer.

In order connect to your BLACKBOX Portable & FTP Server you will need to:

- [Obtain Elspec's Search Utility](#)
- [Use the Utility](#)
- [Access either the Unit or FTP Server with the Utility](#)
- [How to look for a New Device](#)
- [Know its Limitations](#)

Obtain Elspec's Search Utility

Elspec Search is a small program which does not require installation and is available free on the Elspec WEB site: www.elspec-ltd.com. You may also copy it by using the [BLACKBOX Installation CD](#) delivered with the G3500/G4500 unit. Since the program is small and does not require installation, it is recommended copying it and operating it directly from the computer Desktop.

SEE ALSO:

- [About Elspec's Search Utility](#)
- [Obtain the Utility](#)
- [Use the Utility](#)
- [BLACKBOX Unit & FTP Access](#)
- [New Device Indication](#)
- [Limitations](#)

Use the Elspec's Search Utility

- After you have [Copied the Utility](#) on your Desktop, access it by clicking on the Elspec's Search Icon:

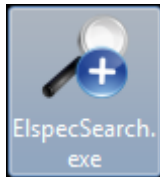

- Initially, the program may trigger a verification warning similar to the one below. You may proceed by clicking **Run**:

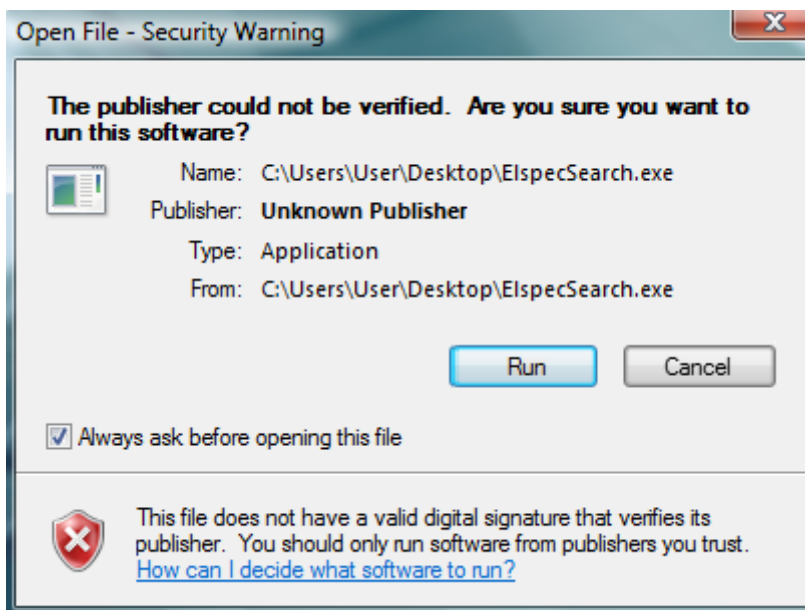

- A scan procedure is initiated; the Elspec Search utility appears as a grid displaying all BLACKBOX devices found on the intranet network:

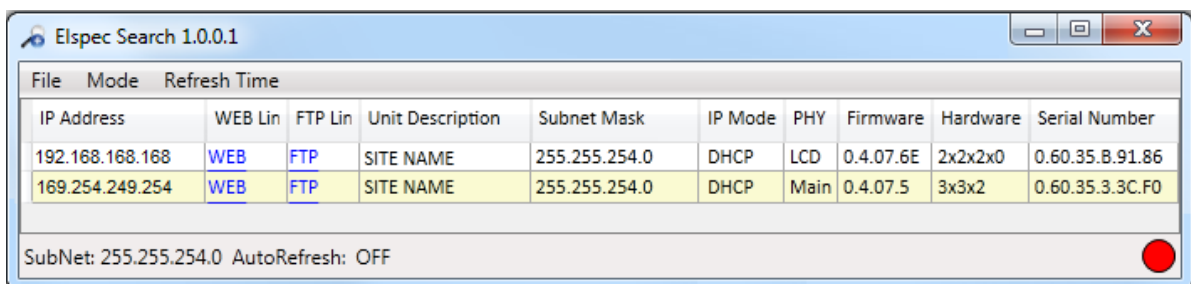

File	Mode	Refresh Time	IP Address	WEB Lin	FTP Lin	Unit Description	Subnet Mask	IP Mode	PHY	Firmware	Hardware	Serial Number
			192.168.168.168	WEB	FTP	SITE NAME	255.255.254.0	DHCP	LCD	0.4.07.6E	2x2x2x0	0.60.35.B.91.86
			169.254.249.254	WEB	FTP	SITE NAME	255.255.254.0	DHCP	Main	0.4.07.5	3x3x2	0.60.35.3.3C.F0

SubNet: 255.255.254.0 AutoRefresh: OFF

- Once open, the scan procedure can be manually prompted by using the **File Refresh List Menu**:

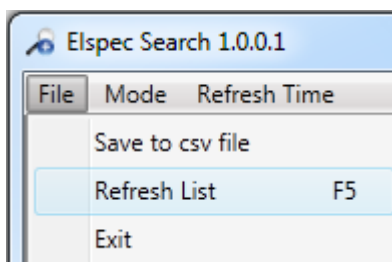

- As an alternative, the scan procedure can be configured to automatically refresh each second. This can be done by setting the Mode ➔ AutoRefresh to **ON**: (The default state is **OFF**)

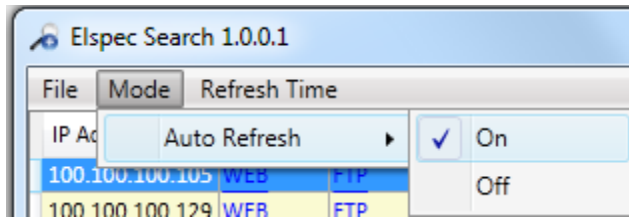

- Set the Refresh Time period by selecting Refresh Time ➔ **Second**:

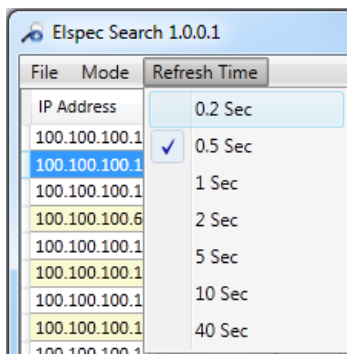

NOTE NOTE NOTE

The Elspec Search list shows a variety of important information about every BLACKBOX device found on network; most of it is helpful to identify devices. It includes the IP Address, Unit Description, SubnetMask, Gateway IP, IP Mode, Firmware Version & the G3500/G4500's Serial Number. The most important information being the **IP address** of each device. This access allows you to [Establish a 1st Time Connection](#).

- By selecting File ➔ **Save to csv file** will allow you to export all the information appearing in the utility regarding BLACKBOX devices in your network for further reference:

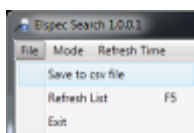

IP Address	Unit Description	Subnet Mask	IP Mode	PHY	Firmware	Hardware	Serial Number
192.168.168.168	SITE NAME	255.255.254.0	DHCP	LCD	0.4.07.6E	2x2x2x0	0.60.35.8.91.86
169.254.249.254	SITE NAME	255.255.254.0	DHCP	Main	0.4.07.5C	3x3x2	0.60.35.3.3C.F0

SEE ALSO:

- [About Elspec's Search Utility](#)
- [Obtain the Utility](#)
- [BLACKBOX Unit & FTP Access](#)
- [New Device Indication](#)
- [Limitations](#)

G4500/G3500 Unit Access

Once you have Connected the Device for the 1st Time, you may access your Portable BLACKBOX by simply clicking the WEB Hyperlink button [in your Elspec's Search Utility](#). Alternatively you can simply access the device directly via Internet Explorer by inserting the Device's IP address directly (address is also indicated in [Elspec's Search Utility](#)). The [Utility](#) also provides you with access to your PQZIP Files via the FTP Server. The Default IP Address for a newly supplied Portable BLACKBOX unit is: **192.168.168.168**.

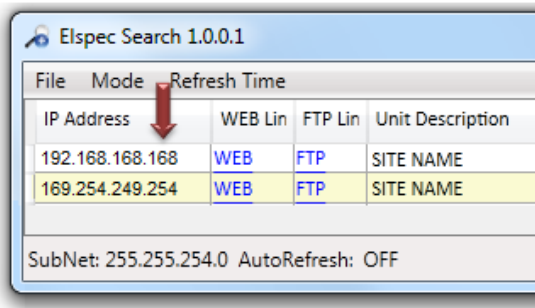

ACCESS INSTRUMENT VIA THE WEB HYPERLINK [RECOMMENDED]:

- Further the [Use the Utility](#) procedure select the **Web** link for your device & Elspec's Web Interface will open:



- In order to view the different languages in the Web Interface, you will need to upload the language feature from [Elspec's Website](#) when installing your new Firmware. Once uploaded, simply select the applicable interface language from the drop-down list:

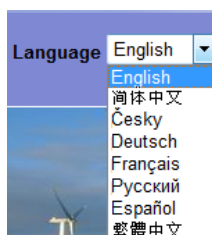

- The supported languages are:
 - English (Default)
 - Chinese
 - Czech
 - German
 - French
 - Russian
 - Spanish

(For other languages - please contact your local Elspec distributor)

- The Password field defines user level/privileges. The user levels are **Viewer / Administrator** (See [Security Settings](#)). The default password including privileges for each level are:
 - Viewer is **123** (Read only, can choose interface language only, no operations related changes are allowed)
 - Administrator is **12345** (Administration, setup & full control)

NOTE NOTE NOTE

- The Website is optimized to work with Internet Explorer 7, 8 or 9 in “Compatibility View”. Ensure that the Internet Explorer is running in **Compatibility View**:

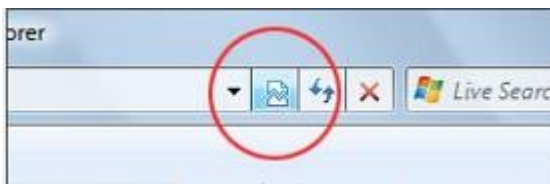

Other web browser applications can limit some functionality and/or show an incorrect layout.

- For local networking the browser should be configured as working without a proxy server. Refer to Disable Proxy Server in Internet Explorer.
- Should you be running Skype simultaneously with Elspec’s Search, you will not be able to access the device via the Web Link. Close Skype & access Elspec’s Search again to follow the Web Link.
- The passwords above are factory default values. You are advised to modify Admin password if extended security measures are required (See [Security Settings](#)).

ACCESS FTP VIA THE FTP HYPERLINK:

The FTP (File Transfer Protocol) link is used for exchanging and manipulating files over a TCP computer network. The BLACKBOX uses an integrated FTP server providing the most convenient computer network standard interface to the generated PQZIP files and auto generated reports. The PQSCADA software system makes use of the FTP server interface by automatically downloading PQZIP files. The same protocol may be used to manually download the PQZIP files.

- Select the **FTP** link for your device, FTP Server will now open:

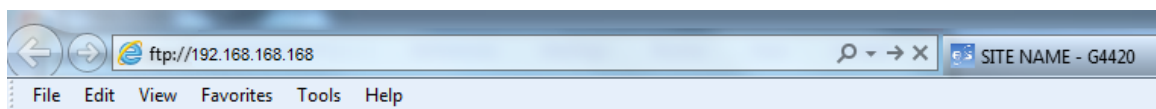

FTP root at 192.168.168.168

To view this FTP site in Windows Explorer: press Alt, click View, and then click **Open FTP Site in Windows Explorer**.

01/01/1970 12:00AM Directory [CF_UPMB](#)

- Open Page ➔ Open FTP Site in Windows Explorer. Insert the Username & Password (Either default as above / as per your [Security Settings](#)) ➔ :

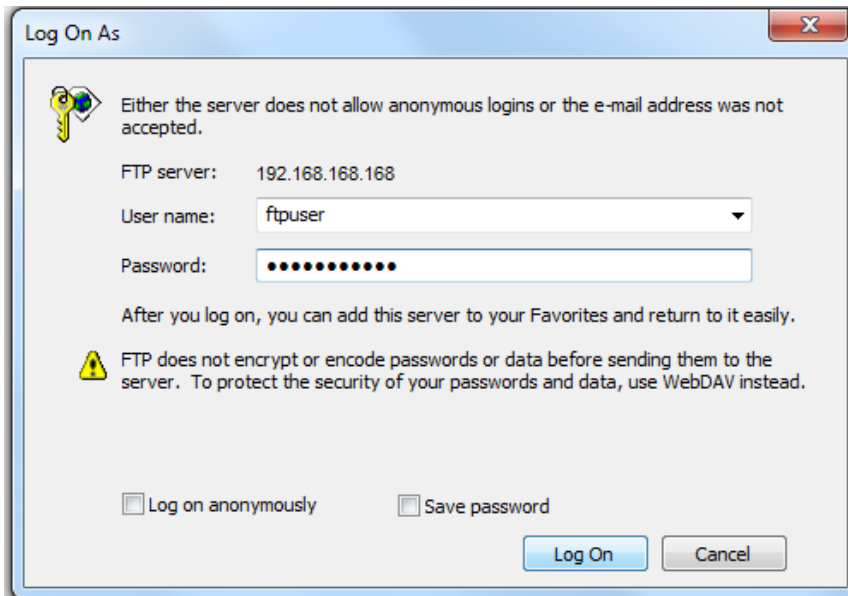

- The FTP server will now open in Windows Explored containing all the PQZIP files:

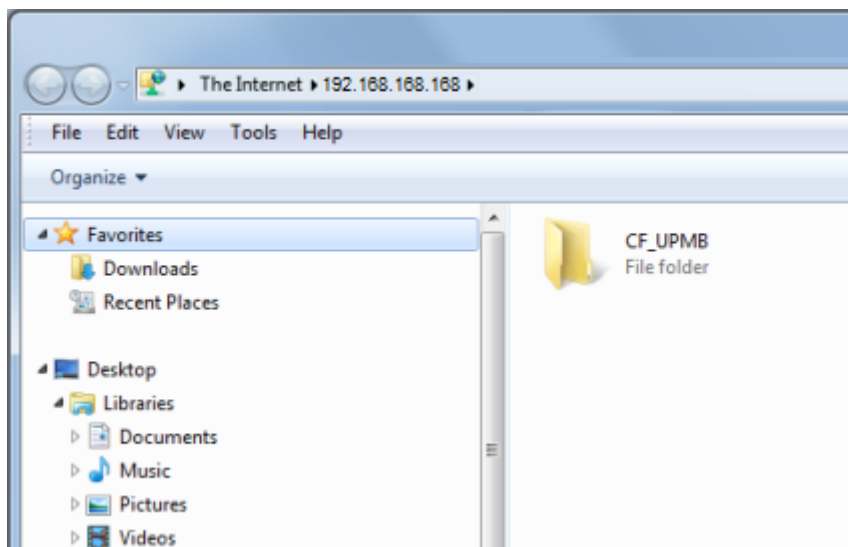

DIRECT FTP ACCESS VIA INTERNET EXPLORER:

Access the FTP by typing: **ftp://IP address** in the address field in Internet Explorer:

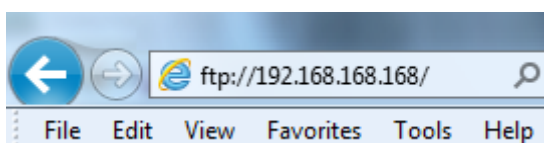

- Enter the password as outlined above.
- Read how to [Identify a New Device](#), about [Elspec's Search Limitations](#).

SEE ALSO:

- [About Elspec's Search Utility](#)
- [Obtain the Utility](#)
- [Use the Utility](#)
- [New Device Indication](#)
- [Limitations](#)

New Device Indication

Every new device that wasn't found after the last refresh is marked in green on Elspec's Search Utility:

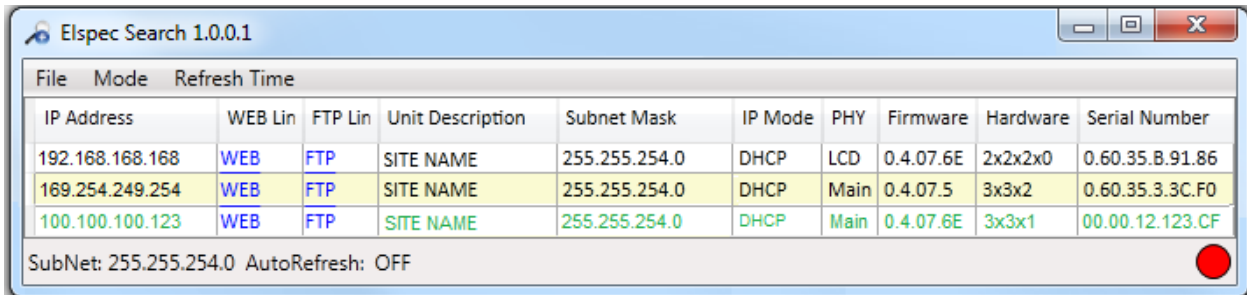

File	Mode	Refresh Time	IP Address	WEB Lin	FTP Lin	Unit Description	Subnet Mask	IP Mode	PHY	Firmware	Hardware	Serial Number
			192.168.168.168	WEB	FTP	SITE NAME	255.255.254.0	DHCP	LCD	0.4.07.6E	2x2x2x0	0.60.35.B.91.86
			169.254.249.254	WEB	FTP	SITE NAME	255.255.254.0	DHCP	Main	0.4.07.5	3x3x2	0.60.35.3.3C.F0
			100.100.100.123	WEB	FTP	SITE NAME	255.255.254.0	DHCP	Main	0.4.07.6E	3x3x1	00.00.12.123.CF

SubNet: 255.255.254.0 AutoRefresh: OFF

SEE ALSO:

- [About Elspec's Search Utility](#)
- [Obtain the Utility](#)
- [Use the Utility](#)
- [BLACKBOX Unit & FTP Access](#)
- [Limitations](#)

Limitations of Elspec's Search Utility

Elspec's Search utility can operate only as one single instance at a time, since it uses a single and fixed UDP port. Should you choose to open a new Search Utility window, only the initial Search Utility window will function properly.

When accessing the device via the Web Link ensure that the Internet Explorer is running in Compatibility View, as some web browser applications can limit the functionality and/or show an incorrect layout:



For local networking, the browser should be configured as working without a proxy server. Refer to Disable Proxy Server in Internet Explorer.

Should you be running Skype simultaneously with [Elspec's Search](#), you will not be able to access the device via the Web Link. Close Skype & access Elspec's Search again to follow the Web Link.

SEE ALSO:

- [About Elspec's Search Utility](#)
- [Obtain the Utility](#)
- [Use the Utility](#)
- [BLACKBOX Unit & FTP Access](#)
- [New Device Indication](#)

Specifications

This section includes common specifications for the Portable BLACKBOX:

INPUT CHARACTERISTICS:

VOLTAGE INPUTS	G4500	G3500
Number of Inputs	AC: 4 (3 Phases & Neutral) DC: 1	AC: 4 (3 Phases & Neutral)
Maximum Input Voltage (V_{RMS})	1KV	1KV
Nominal Voltage Range (V_{RMS})	110 to 690V	110 to 690V
Maximum Peak Measurement Voltage (V_{pk})	8KV	8KV
Input Impedance	3M Ω	3M Ω
Bandwidth	25kHz	12.5kHz
Nominal Frequency	42.5 to 69Hz	42.5 to 69Hz
CURRENT INPUTS	G4500	G3500
Number of Inputs	AC: 4 (3 Phases & Neutral) DC: 1	AC: 4 (3 Phases & Neutral)
Maximum Peak Measurement (V_{pk})	I1 to I4: 10; I5: 3 From Clamp	I1 to I4: 10; I5: 3 From Clamp
Type	Clamp On Current Transformer With mV Output	Clamp On Current Transformer With mV Output
Range (V_{pk})	I1 to I4: 0 to 10; I5: 0 to 3 From Clamp	I1 to I4: 0 to 10; I5: 0 to 3 From Clamp
Bandwidth	6.25/12.5kHz	12.5kHz
SAMPLING SYSTEM	G4500	G3500
Maximum Sampling Rate for Each Channel Simultaneously:		
Voltage	1024 Samples/Cycle	512 Samples/Cycle
Current	256 Samples/Cycle	512 Samples/Cycle
VDC	1 Sample/Second	N/A
Type of Analog to Digital Converter	16/20 ¹ Bit	
Resolution	Dual Range Gain of 2 x 16 Bit On 8 channels	
PLL Synchronization	1024 Samples On 10/12 Cycles According IEC61000-4-7	

¹ Effective Bit

MEASUREMENT RANGE, RESOLUTION, ACCURACY:

VOLT/AMPS/HERTZ	MEASUREMENT RANGE	RESOLUTION	ACCURACY
V_{RMS} (AC & DC) ³	0 to 900V	0.01V	±0.1% of Nominal Voltage ¹
A_{RMS}			
With SOA-9045-3001	90A to 15kA	0.1mA	±0.5% ±0.5A of Nominal Current ²
With SOA-9091-3000	9 to 1.5kA	0.1mA	±0.8% ±0.1A of Nominal Current ²
With SOA-0010-0500	0.02 to 6A	0.1mA	±0.15% ±0.5mA of Nominal Current ²
V_{Pk}	8KV	10mV	±0.1% from Reading
Voltage Crest Factor	1<	0.01	Better than 0.5%
Current Crest Factor	1<	0.01	Better than 0.5%
Hz @ 50Hz Nominal	42.5 to 62Hz	10mHz	±5mHz
Hz @ 60Hz Nominal	51 to 69Hz	10mHz	±5mHz
K-Factor	0<	0.01	±0.25%
DIPS, SWELLS & INTERRUPTIONS	MEASUREMENT RANGE	RESOLUTION	ACCURACY
$V_{RMS}^{1/2}$ (AC & DC)	0 to 900V	0.01V	±0.2% of Nominal Voltage
Duration	HHH,MM,SS,MMM	Half Cycle	One Cycle
Threshold Levels	Programmable Thresholds & Hysteresis in Percentage of Nominal Voltage Event Detection Based Upon ½ Cycle RMS Voltages Captures Dips, Swells, Interruptions & Rapid Voltage Changes		
VOLTAGE HARMONICS	MEASUREMENT RANGE	RESOLUTION	ACCURACY
Harmonic Order	1 to 50 Grouping: Harmonic Subgroups According to IEC61000-4-7		
Inter-Harmonic Order	1 to 50 Grouping: Inter-Harmonic Subgroups According to IEC61000-4-7		
THD _(n=50)	0 to 100%	0.01%	±0.25%
THD Even	0 to 100%	0.01%	±0.25%
THD Odd	0 to 100%	0.01%	±0.25%
Hz (Spectrum)	0 to 3174Hz	fSys 10/12	±5%
Phase Angle	-180 to +180°	0.01°	±0.01°

¹ For Nominal Voltage 80 to 690V

² Depending on the Clamp Accuracy

³ Voltage Measuring Inputs are CAT III per 61010-2-030

MEASUREMENT RANGE, RESOLUTION, ACCURACY:

POWER & ENERGY	MEASUREMENT RANGE	RESOLUTION	ACCURACY
Active Power	Depends on Clamp & PT Configuration	10mW	±0.2% ¹
Reactive Power	Depends on Clamp & PT Configuration	10mVAR	±2% ¹
Apparent Power	Depends on Clamp & PT Configuration	10mVA	±0.2% ¹
Active Energy	Depends on Clamp & PT Configuration	10mWh	±0.2% ¹
Reactive Energy	Depends on Clamp & PT Configuration	10mVARh	½ ¹
Apparent Energy	Depends on Clamp & PT Configuration	10mVAh	±0.2% ¹
True Power Factor	±1 (CAP\IND)	10μ	±0.2% ¹
Displacement Power Factor	±1 (CAP\IND)	10μ	±0.2% ¹
FLICKERING	MEASUREMENT RANGE	RESOLUTION	ACCURACY
P _{SST} , P _{ST} 10 Minutes, S _{PLT} , P _{LT} 2 Hours, L _{PLT}	0 to 20	0.01	±5%
PST _{INST}	0 to 20	0.01	±8%
UNBALANCE	MEASUREMENT RANGE	RESOLUTION	ACCURACY
Volts (Negative & Zero Seq.) Ratio	0 to 100%	0.1%	0.15%
Current (Negative & Zero Seq.) Ratio	0 to 100%	0.1%	0.5% ¹
TRANSIENT CAPTURE			ACCURACY
Minimum Detection Duration			39 μs (G3500)
			19.5 μs (G4500)

¹ Depending on the Clamp Accuracy

GENERAL SPECIFICATIONS:

STORAGE CAPACITY

	G4500	G3500
Internal Memory	32GB	256MB

STORAGE CAPACITY

Optional GPS/SNTP/IRIGB/DCF-77 time sync module provides time uncertainty better than 100 μ s. When synchronization becomes unavailable, Time Tolerance is 1 second per day.

DEVICE SYNCHRONIZATION ACCURACY

COMMUNICATION

CONTROL

Comprehensive web server for local & remote real-time monitoring & control

Standard protocol for main storage memory

PORTS

	G4500	G3500
Ethernet Ports	2 LAN & 1 USB (Integrated Router, NAT & Firewall)	1 LAN
RS-232	1	1
RS-485/422	1	1
Wi-Fi Communications (802.11g)	1 (With Integrated Antenna)	—

LAN 1

Baud Rate	10/100 Mbit
Communication Protocols	TELNET, OPC & SMTP Client
Connector Type	RJ45 Female With Led Indicators
Power Over Ethernet (PoE- In)	1 (Available as Input - 13 Watt, DC: 48V)

LAN 2

Baud Rate	10/100 Mbit
Communication Protocols	TELNET, OPC, & SMTP Client

Connector Type	RJ45 Female With Led Indicators
Power Over Ethernet (PoE- Out)	1 (Available as Output - 13 Watt, DC: 48V)

GENERAL SPECIFICATIONS:

RS485/422 CONNECTION

Baud Rate	Configurable: 1200 / 2400 / 4800 / 9600 / 14400 / 19200 / 38400 57600 / 115200
Communication Protocols	PPP & TTY
Duplex	Full
Maximum Cable Length	15.2m (50')

RS232 CONNECTION (COM COMPATIBLE INTERFACE)

Default Configuration	Baud rate: 19200, Data Bits: 8 , Parity: None, Stop Bits: 1
Communication Protocols	GPS
Duplex	Full
Maximum Cable Length	15.2m (50')

APPLICABLE STANDARDS

Measurement Standards	EN50160, IEEE1159, IEEE519, IEC61000-4-15, IEC61000-4-7, IEC61000-4-30 Class A
EMC Standards	EN61326, CFR47FCC, CISPR11 Group 1, FCC PART 15 Subpart B, EN61010-2, IEC61000-3-3, IEC61000-4-2, IEC61000-4-3, IEC61000-4-4, IEC61000-4-5, IEC61000-4-6, IEC61000-4-11
Environmental Standards	IEC60068-2-1, 2, 6, 27, 30, 75
Safety Standards	EN61010-1:2001 2 ND Edition

POWER SUPPLY

Power Over Ethernet (PoE- In) ¹	According to 802.3af
Operating Range	AC: 100 to 240V @ 50/60Hz DC: 110 to 300V
Auxiliary AC Supply	DC: 48V
Battery Backup	2 Hours

¹ G4500 Unit Only

PQZIP RECORDING:

METHOD		
PQZIP compression technology which enables continuous gap-less ¹ recording of all electrical parameters-related data for a significant time duration without the need of event thresholds of any kind. Events, Flicker and Energy are non-compressed parameters.		
WAVEFORM	G4500	G3500
Voltage Sampling per Cycle	1024/512	512
Current Sampling per Cycle	256/512	512
Recording Time	1 + Year Continuous Recording at a Fixed Ratio Mode of 2.5GB/Month	1 Week Continuous Recording at a Fixed Ratio Mode of 1GB/Month
EVENTS		
Memory	Up to 12K Event Logs	
FLICKER PST		
Recording Interval	10 Minutes	10 Minutes
Recording Time	1 + Year Continuous Recording at a Fixed Ratio Mode of 2.5GB/Month	1 Week Continuous Recording at a Fixed Ratio Mode of 1GB/Month
ENERGY		
Energy Interval	1, 2, 5, 10, 15, 30 & 60 Minutes	
Recording Time	1 + Year Continuous Recording at a Fixed Ratio Mode of 2.5GB/Month	1 Week Continuous Recording at a Fixed Ratio Mode of 1GB/Month

¹ 99.9% of the Time

IO PORTS:

DIGITAL INPUTS

Channels	4
Sampling	800 Hz @ 50Hz (16 Samples per Cycle) 960 Hz @ 60Hz (16 Samples per Cycle)
Range	DC: 0 - 220V
Pulse Type	0->1->0, 1->0->1, KYZ
Isolation Connector	125V

RELAY OUTPUT

Channels	1 x Change Over
Contact Configuration	1 CO (SPDT - Single Pole Double Throw)
Maximum Switching Voltage	AC: 277V
Maximum Current	AC: 5A/250V; 10A/110V DC: 5A/30V
Maximum Peak Current	15A
Rated Current	6A
Operating Time	4ms
Release Time	6ms
Maximum Reaction time	10ms
Maximum Drop-out time	4ms
Output Resistance	50MΩ

SEE ALSO:

- [Physical](#)

Physical Specifications & Dimensions of the Portable BLACKBOX

PHYSICAL SPECIFICATIONS

PHYSICAL	
Dimensions	314mm x 84mm x 269mm (12.36" x 3.3" x 10.59")
Weight	3.7Kg (8.15Lb)
ENVIRONMENTAL	
Design	Rugged, Shock Proof with Integrated Protective Holster
Drip & Dust Proof	IP20 according to IEC60529 when used in tilt standard position
Shock & Vibration	Shock 30g, Vibration: 3g Sinusoid, Random 0.03 g2/Hz According to MIL-PRF-28800F Class 2
Operating Temperature	-0 to 40°C (32 to 104°F)
Storage Temperature	-20 to 60°C (-4 to 140°F)
Humidity	85%
Maximum Operating Altitude	2Km (1.24Mi)
Warranty	One Year
TEMPERATURE SENSORS	
External Temperature Sensor (PT100)	-40 to 90°C (-40 to 210°F)
Internal PSU Temperature Sensor	Informative
Internal DSP Temperature Sensor	Informative

DIMENSIONAL VIEW G4500:

Front View

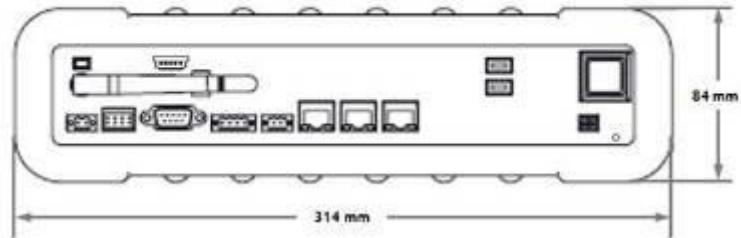

Side View

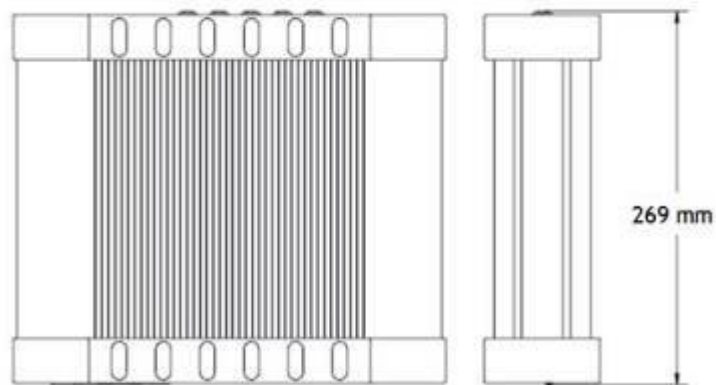

Back View

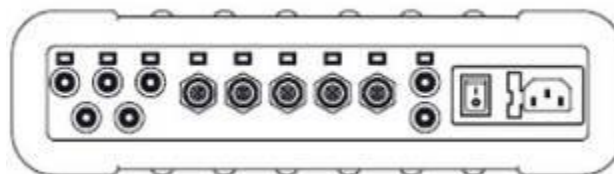

DIMENSIONAL VIEW G3500:

Front View

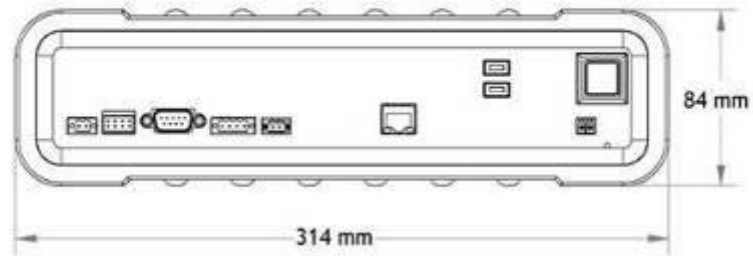

Side View

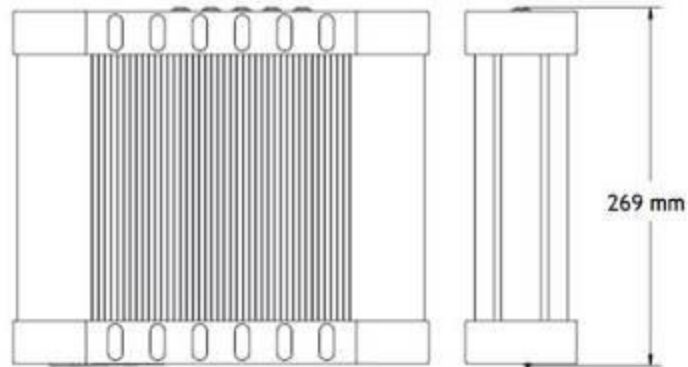

Back View

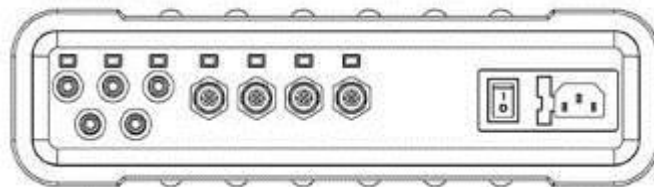

SEE ALSO:

- [G4500 G3500 Specifications](#)



A Worldwide Innovator in Power Quality

International
ELSPEC Ltd.
info@elspec-ltd.com

North America
ELSPEC North America, Inc.
info@elspecna.com

Europe
ELSPEC Portugal Lda.
info@elspecportugal.com

India
ELSPEC Engineering India Pvt Ltd.
info@elspec.in