

## RI-F100-G-C

### Three Phase Multifunction Energy Meter (MID Certified)



**MID**



- DIN 96 panel mounted
- -/1A or -/5A current transformer input (MID certification only on 5A)
- Three phase network compatible
- Programmable voltage and current transformer ratio
- True RMS measurement
- MID B+D Certified
- High definition white backlit LCD display
- Compact size - only 50mm panel depth
- Simple programming and operation
- Pulse output and RS485 Modbus communication
- Auto and manual page scrolling

#### Product Description

The RI-F100 Series are a range of MID approved 96mm panel mounted multifunction energy meters. Suitable for monitoring energy consumption and many other electrical parameters in residential, solar PV, industrial and commercial utility applications.

These meters may be used in three phase four wire systems.

A high efficiency white backlit LCD display provides a clear indication of the measured value in all light conditions. Quick select push-buttons on the front of the meter allow the user fast access to the display page required.

The meter is currently available in one version:-

- With single pulse output and RS485 Modbus communication.

The unit is housed in a compact DIN 96 case suitable for panel mounting.

#### Displayed Parameters

**Voltage – L-L, L-N and average**

**Current – Phase, total and Max. demand**

**Power Factor – per phase and average**

**Total Harmonic Distortion – Current and Voltage**

**Neutral current (calculated)**

**Frequency**

**Hours Run – Hours & minutes**

**Power – Active, Reactive and Apparent (per phase and total)**

**Power Min./Max. demand – Active, reactive and apparent.**

**Energy – Active, reactive and apparent (per phase and total)**

**Import and export energy – Active, Reactive and Apparent (per phase and total)**

## Display

Display Type	High definition white backlit LCD
Digit height	11.2mm (displayed parameter) 6.35mm (lowest 8 digits)
Page scrolling	Manual by front key / or auto scroll mode
Displayed parameters and accuracies	Voltage 0.5% of full scale Current 0.5% of full scale Frequency 0.1% of full scale (L - N > 20V) Power factor 1% of unity Active power 1% Reactive power 1% Apparent power 1% Active Energy Class 1, Class B (IEC/EN62053-21, IEC/EN50470-3) Reactive Energy Class 2 (IEC/EN62053-23) Total Harmonic Distortion (THD - up to 31st) 3%
Energy maximum display	99999999
Resolution	0.01K, 0.1K, 1K, 0.01M, 0.1M, 1M (depending on CT ratio & VT ratio)

## Programming

Parameters that can be changed using programming menu  <i><b>NOTE: Once Programming Mode Is entered The values in red will be locked out after 15 Mins. No further adjustment is possible without return to factory.</b></i>	CT Primary current CT Secondary current VT primary voltage VT secondary voltage Communication address Communication speed (Baud) Communication Parity Communication number of stop bits Back-light time-out period Demand period (for integration) Pulse output (kWh) Pulse duration Reset to Factory Default Reset Energy and Maximum Demand Reset Active Energy Reset Reactive Energy Reset Apparent Energy Reset Maximum Current Reset Maximum Active Power Reset Minimum Active Power Reset Maximum Reactive Power Reset Minimum Reactive Power Reset Maximum Apparent Power
Programming access	Password protected (user selectable)
Memory retention	Non volatile memory

## Input

Connection	Three phase four wire
Input voltage range	11...300V (L - N), 19...519V (L - L)
Certified voltage range	MID certified for 3 x 230V/400V $\pm$ 10%
Voltage rated burden	<0.2VA
Nominal current input	0.05...5A
Max current (Imax)	6A (1.2 x Nominal)
Current Rated Burden	<0.003VA @ 6A
Starting current	10mA
Short time over-current	30 x Imax to IEC/EN62053-21 + 23
Impulse voltage withstand	6kV 1.2/50 $\mu$ S 0.5J
AC voltage withstand	3kV 50Hz for 1 min.
CT primary current	5...6000A
VT primary voltage	100...600V
Frequency	50Hz
Current distortion factor	According to IEC/EN50470

## Auxiliary Supply

Voltage range	100...240V ( $\pm$ 15%)
Operating frequency	50/60Hz
Power consumption	<8VA

## Outputs

<b>Energy pulses</b>	
Number of pulse outputs	1
Pulse output function	kWh
Pulse output type	Semiconductor (does not support volt-free operation)
Pulse output Max. current	100mA
Pulse output voltage range	5...27VDC
Pulse duration	100ms...2s
Pulse resolution	0.01K, 0.1K, 1K, 0.01M, 0.1M, 1M (depending on CT ratio & VT ratio)
<b>Communication</b>	
Communication type	RS485
Communication protocol	Modbus RTU
Address	1...255
Number of bits	8bits
Parity	None, odd, even
Baud rate	300, 600, 1200, 2400, 4800, 9600, 19200
Required response time to request	$\leq$ 100ms
Number of meters connected on the bus	32 (up to 255 with RS485 repeater)
Max distance from Master device	500M

## Insulation

Installation category	III
Pollution degree	2
Insulation voltage rating	300V (L - N)

## Environmental Conditions

Reference temperature	23°C ±2°C
Specified temperature operating range	-10°C...+55°C
Storage temperature	-20°C...+70°C
Relative humidity	0...85%, non-condensing
Mechanical environment	M2
Electromagnetic environment	E2

## Mechanical

<b>Housing</b>	
Housing	DIN96
Mounting	Panel mounted (Max. panel thickness 6mm)
Tamper sealing	Meter housing (by means of a tamper evident seal). Sealable terminal covers
Housing material	Self-extinguishing polycarbonate (UL94 V-0)
Protection degree (IEC/EN60529)	IP20 (terminals), IP54 (front of housing)
Weight	<320g
<b>Termination</b>	
Current input terminal type	Screw clamp type
Max. wire size	2.5mm <sup>2</sup>
Voltage input terminal type	Screw clamp type
Max. wire size	2.5mm <sup>2</sup>
Communication output (RS485 and Pulse)	Screw clamp type
Max. wire size	1.5mm <sup>2</sup>

## Conformity

Electromagnetic compatibility	IEC/EN61326-1, IEC/EN55011 Class A, IEC/EN61000-4-2, -3, -4, -5, -6, -8, -11, IEC/EN50470-1/3
Accuracy and functionality	IEC/EN50470-1/3, IEC/EN62053-21, IEC/EN62053-23, DIRECTIVE 2014/32/EU
Safety	IEC/EN61010, IEC/EN62052-31

## Wiring Diagrams

**Note:** # All fuse types : 0.5A class CC UL type  
0.5A fast acting 600V

### 3 Phase 4 Wire - 3 CTs

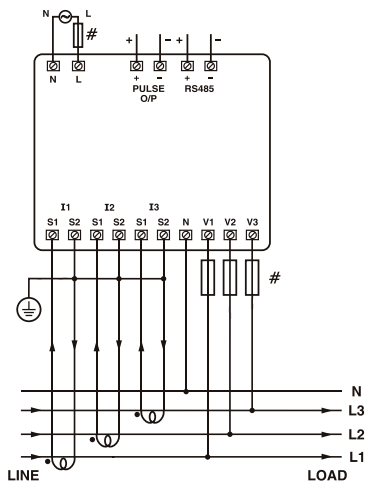

### 3 Phase 4 Wire - 3 CTs and 3 PTs

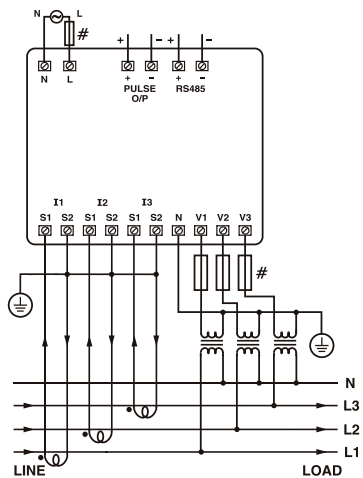

## Accessories

The RI-F100 comes supplied with transparent terminal covers with holes for anti-tamper tags and clip-in ratcheted fixing clips for easy and precise fitting of the meter.



## Dimensions

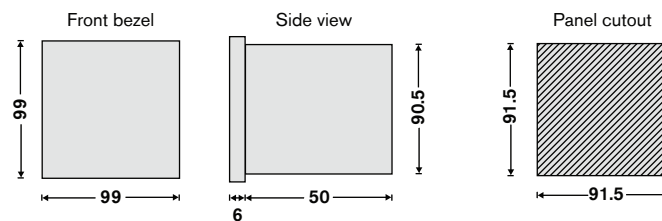

## Model Selection Table

Communications	Model
Modbus and pulse output	RI-F100-G-C