



# Defender<sup>®</sup> 8000

Touchscreen Indicator



## ***Taking Industrial and Commercial Weighing to the Next Level***

The Defender 8000 T82XW indicator gives the user full-control over operating the scale on a touchscreen LCD via guided instructions. Not limited to data display, the T82XW is ideal for process control, recipe formulation and data management—and intuitive software allows for customizable applications. Constructed of water-resistant IP68 stainless steel, the T82XW is built to withstand demanding use in industrial and commercial applications.

### ***Standard Features Include:***

- **Perform Versatile Weighing Functions**

The T82XW not only displays weighing data clearly, but you can customize and program the interface to suit specific weighing needs—including SQC, Industry labelling, process control, multi-batching etc.

- **View Results Clearly and Operate Intuitively Via Instructions on Display**

Instructions on the color touchscreen display guide the user through the operational processes, enhancing the user-experience. So intuitive to use, minimal training is required—saving time and money.

- **Efficient Data Transfer and Storage with Multiple Connectivity Options**

Connect via RS232, USB or Ethernet to a computer or printer to transfer and store data for back-office use. Optional Analog and I/O interface allows T82XW to communicate with PLC for process weighing.

# Defender® 8000 Touchscreen Indicator

## Versatile Weighing Functions

The T82XW indicator features advanced applications including Accumulation and Formula Weighing, Counting, SQC (Statistical Quality Control), Industrial Labeling, Dosage Systems and more. This allows customers to create their own applications—edit messages, serial port management, customization of protocols, digital I/O full management, sequential or simultaneous automations, data entry and custom archives.

## Intuitive Touchscreen Display

The large touchscreen display and mechanical numeric keypad makes the T82XW ideal for advanced industrial applications—allowing for visualization of weighing data and customization of screens, to simplify the user experience.

## Multiple Connectivity Options

Three RS232 serial ports allow for easy connection to a printer, PC or PLC, and optional interfaces. Optional fitted keyboard emulation input available through cable with mini DIN connector for barcode/badge readers or external PC keyboard. Four opto-isolated outputs, two opto-isolated inputs are also available as option.

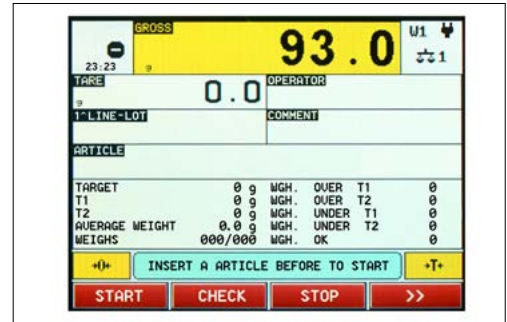

SQC



## Outline Dimensions

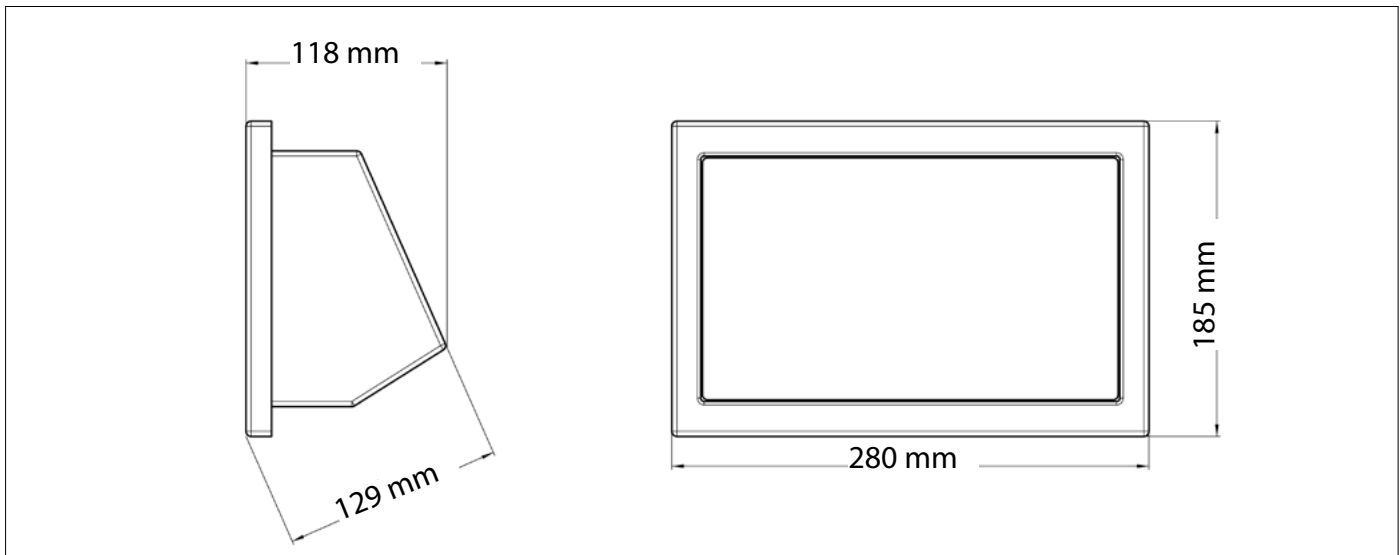

## Multiple Connectivity

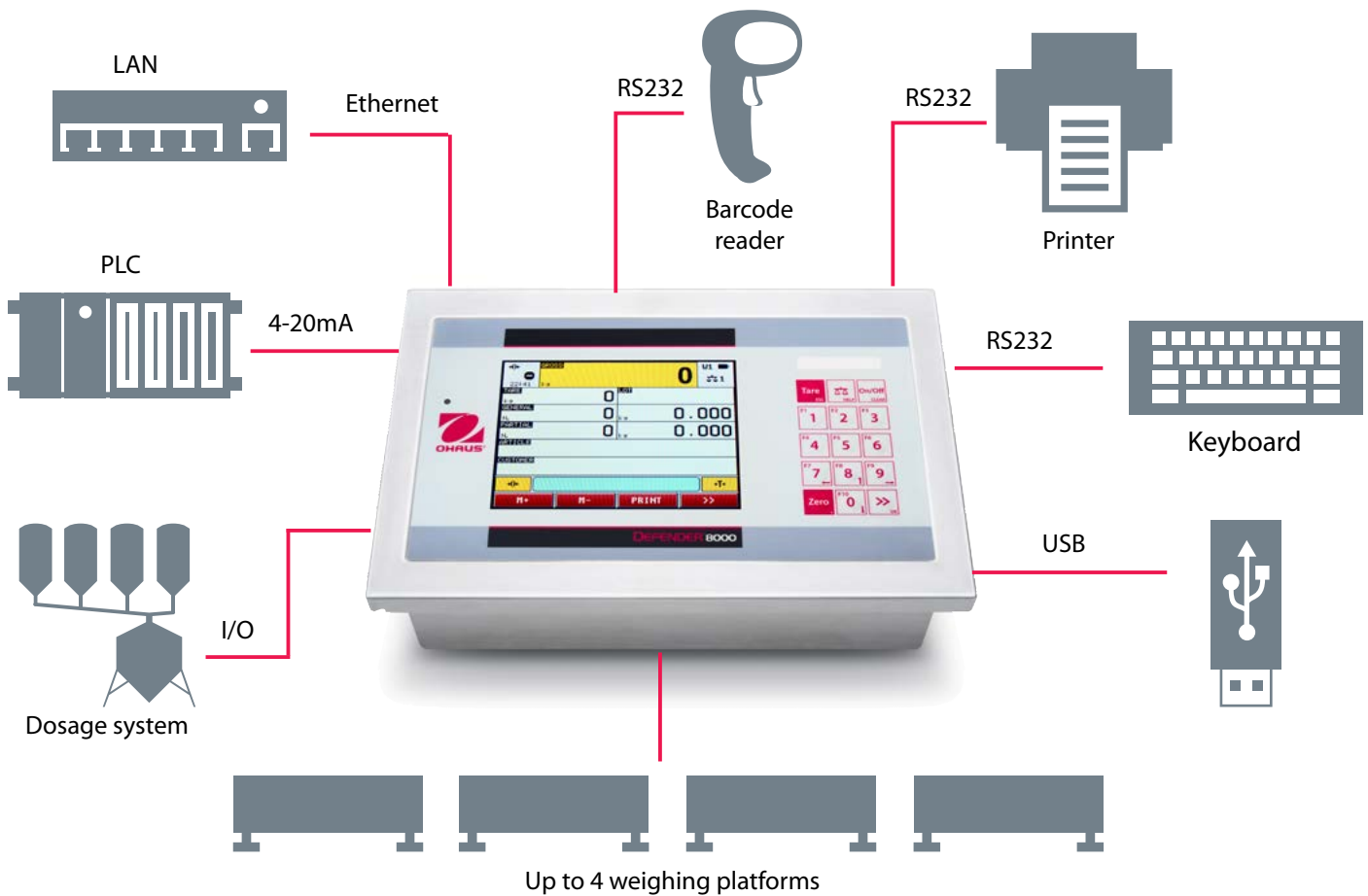

## Application Modes

- **Accumulation and Formula Weighing\***—Advanced applications of weight totalization and formula weighing with data, database and print management.
- **Parts Counting**—Piece counting and data management with article, client and tare databases, and customization of printouts. Internal counting resolution up to 1,500,000 points. Up to four independent scales.
- **Vehicle Weighing**—Vehicle weighing and weighbridge management with input/output control of goods. To weigh the vehicle by itself or with the trailer.
- **SQC**—Advanced statistical checking applications of pre-packed goods with data and print management (as provided by the directive 76/211/EEC). Up to four independent scales.
- **Price Computing and Industrial Labeling**—Advanced price computing function with evolved article management enables to indicate on the label important information regarding traceability through the most requested codifications. The flexibility of configuration together with the large memory storage space, allows to satisfy the most diverse requirements of use.
- **Single Product Dosage Systems**—Create single product dosage systems in loading (useful for filling hoppers, silos or big bags), and in unloading (useful for dividing the quantity of materials of equal weight or extract precise quantities from the silo). Database of 500 formulas.
- **Multi-Component Dosage Systems**—Automatic multi-component and multi-scale dosage systems with optional I/O kit. Database of 100 different activities and 500 formulas. Direct management of 12 different components through the relay. Completely programmable print-outs.

\* Accumulation and formula weighing application software is installed. Please contact your local OHAUS Dealer for assistance with other application software.

# Defender® 8000 Touchscreen Indicator

Model	T82XWT
Capacity	Up to 999999 (t, kg, g or lb)
Maximum displayed resolution	1:1,000,000
Maximum approved resolution	1:10,000 or 3 × 3000e @ 0,3 µV/d (EC, OIML)
Weighing units	kg, lb, g, t
Weighing modes	Accumulation and Formula Weighing, Parts Counting, Vehicle Weighing/Weighbridges, SQC, Price Computing and Industrial labelling, Single Product Dosage Systems, Multi-component Dosage Systems
Display	Six-inch (150 mm) full-color graphic touchscreen display, 320x240 pixels
Under/Accept/Over indicators	≤2 s
Controls	* 15-key alphanumeric waterproof keyboard * Selectable QWERTY, AZERTY or QWERTZ keyboard integrated in the touch screen
Ingress protection	IP68
Load cell excitation voltage	5 VDC
Load cell drive	Up to 16 × 350 ohm load cells
Load cell input sensitivity	Up to 3 mV/V
Stabilization time	Within 2 seconds
Auto-zero tracking	Off, 0,25d, 0,5d, 1d, 2d, 4d, 8d, 10d
Zeroing range	+/-2% or +/-10% of capacity
Interfaces	3× RS232, micro SD, 2× opto-isolated input (optional), 4× opto-isolated output (optional), analog output DAC160 (optional), USB (optional), Ethernet (optional), RS485 optoisolated (optional)
Operating temperature range	-10 °C to 40 °C
Mains power	110–240 VAC, 50/60 Hz internal power supply
Housing dimensions (W × D × H)	280 × 143 × 185 mm
Net weight	3.2 kg
Shipping weight	4 kg
Shipping dimensions	470 × 250 × 170 mm

## Standard Equipment

Three color checkweighing lights, multi-operating languages, QWERTY, AZERTY, QWERTZ keyboard options integrated in the touchscreen, real-time clock, alibi memory, built-in micro SD slot for recording configuration, logos and customized screens, four independent analog channels, T82XW tool (allows for configuration, data entry and print formatting, recording and filing of all the information on PC, complete retrieval of the configuration, instrument calibration with numeric values and customization of screens)

## Compliance

- **Marking:** CE
- **Metrology:** EN 45501 (GB-1589), OIML R76 (R76/2006-GB1-16.10) Class III, nmax 10000
- **Product Safety:** EN 61010-1, EN 61010-2-030
- **Electromagnetic Compatibility:** EN 61326-1 Class B, Industrial environments

## Accessories

I/O Input (2 pcs) .....	30325822
I/O Output (4 pcs) .....	30325823
Analog Output kit .....	30344022
6 inch/12 Out I/O kit .....	30344023
Multi L/C Input kit, 4 Channel .....	30331635
USB Drive kit .....	30331636
RS232 to USB kit .....	30331637
Ethernet kit .....	30331642
Opto-isolated RS485 kit .....	30331643
Wall Mount kit .....	30331644
In-Use Cover kit (10 pcs) .....	30328139
License for Display Tool .....	30344025
Serial to Mini DIN Connector .....	30344026
RS232/C Serial Cable 1.5 m .....	30344027
Ethernet Cable 1.5 m .....	30344028

OHAUS Europe GmbH  
Im Langacher 44  
8606 Greifensee  
Switzerland

e-mail: [ssc@ohaus.com](mailto:ssc@ohaus.com)  
Tel: 0041 22 567 53 19  
e-mail: [tsc@ohaus.com](mailto:tsc@ohaus.com)  
Tel: 0041 22 567 53 20

[www.ohaus.com](http://www.ohaus.com)

OHAUS Corporation is an ISO  
9001:2008 manufacturer

ISO 9001:2008  
Registered Quality  
Management System

CH16D351

