

NEW

MI 3108 EurotestPV

Electrical and Photovoltaic Installations Tester



MI 3108 EurotestPV is a combined photovoltaic tester and electrical installations safety tester. It enables complete testing of electrical installations according to EN 61557 standards and in addition performs all necessary tests required on single-phase photovoltaic (PV) installations. This includes all of the tests as required by EN 62446, but also includes I - U characteristic, Calculation of STC values and power measurements on inverter's DC and AC sides.

The unit is designed for the demanding working conditions (up to 1000 V, with 15 A DC). To greatly improve user safety the MI 3108 EurotestPV comes with the PV Safety Probe which ensures safe disconnection every time.

MEASURING FUNCTIONS

Photovoltaic installations:

Measurements on DC side of PV installation:

- Voltage, current, power, energy;
- Uoc (Open Circuit Voltage) and Isc (Short Circuit Current);
- I - U curve of PV modules and strings;
- Irradiance;
- Module temperature.

Measurements on AC side of PV installation (power quality):

- Voltage, current, frequency, power, PF, energy, harmonics;
- Efficiency of PV module, inverter, PV system calculation.

Electrical installations:

- Insulation resistance;
- Continuity of PE conductors;
- Line impedance;
- Loop impedance (sub-functions with high current and without RCD tripping);
- RCD testing (type AC, A and B);
- Earth resistance;
- AC current (load and leakage);
- TRMS voltage, frequency, phase sequence;
- Power, energy, harmonics.

KEY FEATURES

Photovoltaic installations:

- Calculation of STC values;
- Efficiency calculations;
- Graphical representation of module's I - U curve;
- 2 voltage & 2 current channels for simultaneous AC & DC parameters measurements;
- Optional PV Remote Unit for simultaneous measurements of solar irradiation and temperature of PV module.

Electrical installations:

- Automated RCD testing procedure;
- Support for B type RCD;
- Earth resistance measurement;
- Built-in fuse tables for automatic evaluation of the line / loop impedance results;
- Online monitoring of all 3 voltages;
- Scope function;
- Loop impedance test without tripping the RCD;
- 1-phase power and energy measurements (including harmonics up to 11th).

APPLICATIONS

- Testing, evaluations and troubleshooting of photovoltaic installations.
- Power and energy efficiency measurements (AC and DC).
- Initial and periodic testing of domestic and industrial single and three-phase electrical installations.

GENERAL FEATURES

- Large internal memory: ca 1800 measurements or ca. 500 measurements of I-V curve or Power (Scope) or adequate combination.
- Built-in help screens with connection diagrams for each function.
- Tester has a built-in charging circuit and comes complete with a set of rechargeable NiMH batteries.
- PC SW EuroLink PRO included in the standard set enables downloading of test results and parameters and creation of test reports.
- PC SW EuroLink PRO Plus enables creation of Professional Installation test reports.

STANDARDS

Functionality:

- IEC/EN 61557 series;
- IEC 62446 (photovoltaics).

Other reference standards for testing:

- BS 7671; EN 61008; EN 61009;
- EN 60364-4-41; AS/NZ 3760

Electromagnetic compatibility:

- EN 61326

Safety (LVD):

- EN 61010-1; EN 61010-2-030;
- EN 61010-031; EN 61010-2-032



Technical Specification

PHOTOVOLTAIC INSTALLATION MEASUREMENTS		
Function	Measuring range	Basic accuracy
Voltage	0 V DC ... 999 V DC 0 V AC ... 999 V AC I-V m.: 0 V DC ... 999 V DC	±(1.5 % of reading + 5 digits) ±(1.5 % of reading + 3 digits) ±(2 % of reading + 2 digits)
Current	Panel m.: 0.0 mA ... 300 A DC Invert. m.: 0.0 mA ... 300 A AC I-V m.: 0.00 A ... 15 A DC	±(1.5 % of reading + 5 digits) ±(1.5 % of reading + 3 digits) ±(2 % of reading + 3 digits)
Power	Panel m.: 0 ... 200 kW I-V m.: 0 ... 15 kW	±(2.5 % of reading + 6 digits) ±(3 % of reading + 5 digits)
Energy	0.000 Wh - 1999 kWh	
U / I curve	1000 V / 15 A / 15 kW	
Harmonics	up to 11 th	
Irradiation	0 ... 2000 W/m ²	±(5 % of reading + 5 digits)
Temperature	-10 °C ... + 85 °C	± 5 digits
ELECTRICAL INSTALLATION MEASUREMENTS		
Function	Measuring range	Basic accuracy
Insulation resistance (EN 61557-2)	U = 50, 100, 250 VDC: R: up to 199.9 MΩ U = 500 VDC, 1 kVDC: R: up to 999 MΩ	±(5 % of reading + 3 digits) ±(5 % of reading + 3 digits)
Continuity, 200 mA (EN 61557-4)	0.00 Ω ... 1999 Ω	±(3 % of reading + 3 digits)
Continuity, 7 mA	0.0 Ω ... 1999 Ω	±(5 % of reading + 3 digits)
Loop impedance (EN 61557-3)	0.00 Ω ... 9.99 kΩ	±(5 % of reading + 5 digits)
Line impedance (EN 61557-3)	0.00 Ω ... 9.99 kΩ	±(5 % of reading + 5 digits)
Voltage	0 VAC ... 550 VAC	±(2 % of reading + 2 digits)
Frequency	0.00 Hz ... 499.9 Hz	±(0.2 % of reading + 1 digits)
Phase sequence (EN 61557-7)	1.2.3 or 3.2.1	
RCD testing (EN 61557-6)	ΔIN: 10 mA, 30 mA, 100 mA, 300 mA, 500 mA, 1 A	
- Contact voltage UC	0.0 V ... 99.9 V	(-0 % / +15 %) of reading
- Trip-out time	0 ms ... max. time	±1 ms
- Trip-out current	0.2 x IΔN ... 2.2 x IΔN	±0.1 x IΔN
Earth resistance (EN 61557-5)	0.00 Ω ... 9999 Ω	±(5 % of reading + 5 digits)
General	Main unit	Remote unit
Display	128 x 64 dots matrix display with backlight	
Power supply	6 x 1.2 V NiMH batteries, type AA	
Overvoltage category	1000 V DC / CAT II 600 V / CAT III; 300 V / CAT IV	
Protection class	double insulation	
COM port	RS232 and USB	RS232
Dimensions	230 x 103 x 115 mm	140 x 230 x 80 mm
Weight	1.3 kg	1.0 kg

PV System parameters

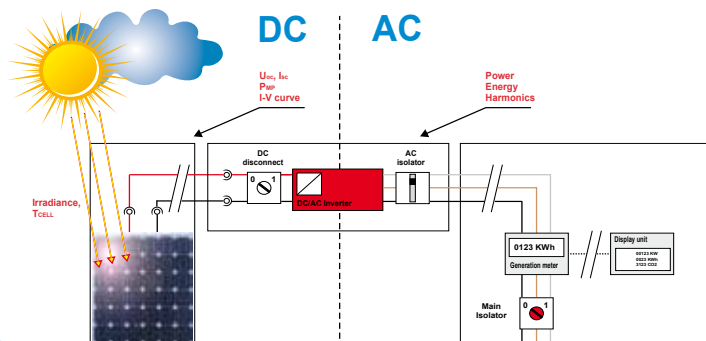

Ordering information

Standard set

MI 3108 ST



- Instrument MI 3108 EurotestPV
- Soft carrying bag, 2 pcs
- Plug commander
- Test lead, 3 x 1.5 m
- Test probe, 3 pcs (blue, black, green)
- Crocodile clip, 3 pcs (blue, black, green)
- PV Safety Probe
- PV MC3/4 male/female adapters
- AC/DC current clamp
- Pyranometer
- Temperature probe
- Power supply adapter + 6 NiMH batteries, type AA
- USB and RS232 - PS/2 cable
- PC SW EuroLink PRO
- Set of carrying straps
- Short instruction manual
- Instruction manual and handbook on CD
- Calibration certificate

Pro set

MI 3108 PR

- MI 3108 ST
- A 1378 EurotestPV Remote
- A 1018 Current clamp (low range, leakage)
- A 1385 PV fused test lead

Optional accessories

Photo	Order No.	Description
	A 1378	EurotestPV Remote
	A 1401	Tip Commander
	A 1018	Current clamp (low range, leakage)
	A 1391	AC/DC Current clamp
	A 1105	Barcode scanner
	AM 1337	RFID HGL
	A 1110	Three phase adapter
	A 1111	Three phase adapter with switch
	A 1385	PV fused test lead
	S 2026	Earth 20 m set, 3 wire
	S 2027	Earth 50 m set, 3 wire
	A 1292	Upgrade code EuroLink PRO to EuroLink PRO Plus



Measuring and Regulation Equipment Manufacturer

METREL d.d.
Ljubljanska 77
SI-1354 Horjul
Tel: + 386 (0)1 75 58 200
Fax: + 386 (0)1 75 49 226
E-mail: metrel@metrel.si
http://www.metrel.si

Note! Photographs in this catalogue may slightly differ from the instruments at the time of delivery. Subject to technical change without notice.